

Extra-tall merchandiser maximizes your profits with the most vertical facings and greatest product capacity.



High Multi-Deck Case

O5DMH-NRG

*Merchandiser for Dairy, Deli
and Produce*



Hill PHOENIX

DISPLAY CASES

O5DMH-NRG

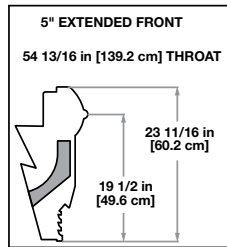
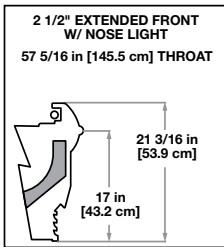
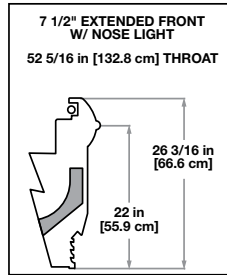
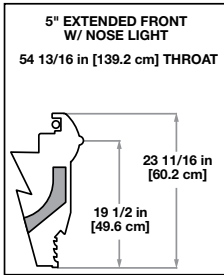
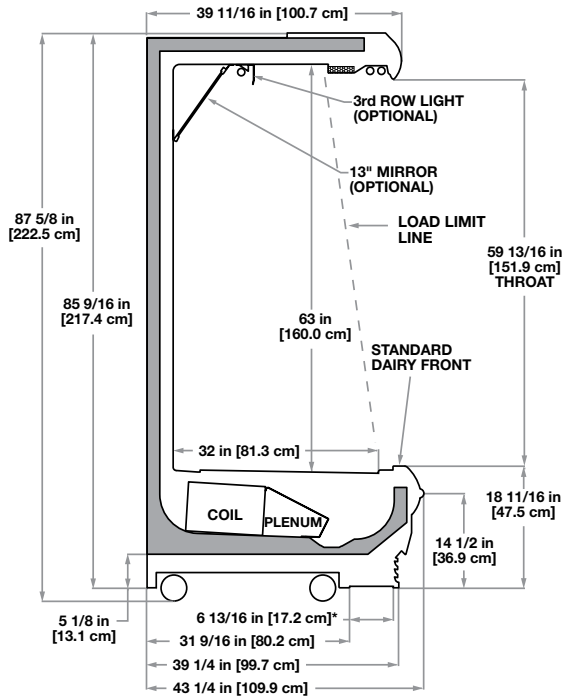

Please consult Hill PHOENIX Engineering Reference Manual for dimensions, plan views and technical specifications. Specifications subject to change without notice. Designed for optimal performance in store environments where temperature and humidity do not exceed 75°F and 55% RH. Certified to UL 471 and ANS/NSF Standard 7.

Cross Section

Standard with each O5DMH-NRG is Hill PHOENIX's exclusive Synerg-E™ Technology with NRGcoil, ECM fans and Advance Airflow Management system. Synerg-E maintains product integrity while saving you money. Meets DOE 2012 requirements!

Available Options:

- Four lengths available: 4', 6', 8' and 12'.
- Four Front Sill Heights Available: 18", 21", 23" and 26".
- Configure with a variety of front panel design options, including Standard ORIGIN2, Classic Hybrid, Classic Metal, and Flat Front.
- Full-view, solid or square ends available with various interior finishes.
- Clearvoyant™ LED Lighting System.
- Available shelf sizes: 10", 12", 14", 16", 18", 20", 22" and 24".
- Epoxy-coated wire or plexiglass package stops maintain attractive shelf displays.
- Angled mirrors in 9" or 13" heights.
- Exclusive SmartValve™ energy-saving technology available.
- Environmentally-friendly Second Nature® secondary coolant application available.

Features and Benefits:

- Unique design ensures uniform case performance and lower average product temperatures with optimum energy efficiency.
- All-steel construction for increased life span and structural integrity.
- Standard off cycle defrost for cost-effective operation.
- Seamless tank liner provides positive drain runoff and enhanced sanitation.
- Bottom-mounted NRGcoil™ and lift-up fan plenum for ease of maintenance.
- Meets DOE 2012 requirements.
- Removable castors for easy merchandiser unloading, movement and placement.



Hill PHOENIX

DISPLAY CASES

1925 Ruffin Mill Rd., Colonial Heights, VA 23834

804-526-4455 phone • 804-526-2804 fax

website: www.hillphoenix.com

e-mail: marketing-case@hillphoenix.com