

Self-Service Open Single-Deck Merchandiser

DLPF REMOTE - 4', 6', 8', 10' & 12'

Electrical Data

Model		Fans per Case	High Efficiency Fans		Anti-Condensate Fans		Drain Heaters		Optional Defrost Heaters	
			120 Volts		120 Volts		120 Volts		208 Volts	
			Amps	Watts	Amps	Watts	Amps	Watts	Amps	Watts
DLPF	4'	2	0.6	72	---	---	---	---	---	---
	6'	3	0.9	108	---	---	---	---	---	---
	8'	3	0.9	108	---	---	---	---	---	---
	10'	4	1.2	144	---	---	---	---	---	---
	12'	4	1.2	144	---	---	---	---	---	---

Lighting Data

Model		Lights per Row	Light Length (ft)	Clearvoyant 4 LED Lighting (Per Light Row)			
				Standard Power (Cornice or Shelf)		High Power (Cornice)	
				120 Volts		120 Volts	
				Amps	Watts	Amps	Watts
DLPF	4'	1	4	0.05	5.9	0.12	14.9
	6'	2	3	0.08	9.4	0.20	23.8
	8'	2	4	0.10	11.8	0.24	29.8
	10'	2	5	0.12	15.0	0.30	37.0
	12'	3	4	0.15	17.7	0.36	44.7

Guidelines & Control Settings (DX)

Model	Conventional ² BTUH/ft	Parallel ³ BTUH/ft	Superheat Set Point @ Bulb (°F)	Evaporator (°F)	Discharge Air (°F)	Discharge Air ⁴ Velocity (FPM)
DLPF	1004	924	6-8	26	34	200

Defrost Controls

Model	Defrosts per Day	Run-Off Time (min)	Electric Defrost		Timed-Off Defrost		Hot Gas Defrost	
			Fail-Safe (min)	Termination Temp (°F)	Fail-Safe (min)	Termination Temp (°F)	Fail-Safe (min)	Termination Temp (°F)
DLPF	6	---	---	---	30	42	---	---

1 NOTE: "---" indicates data not applicable.

2,3 Listed BTUH indicates unlighted shelves. Add the following for lighted shelves:

- 4' Shelf LED: 36 BTUH
- 4' Canopy LED: 72 BTUH
- 3' Shelf LED: 27 BTUH
- 3' Hi-Output LED: 54 BTUH

4 Average discharge air velocity at peak of defrost.

Engineered for stores with ambient conditions not to exceed 75° and 55% relative humidity.

Due to engineering improvements specifications may change without notice.

All measurements are taken per ASHRAE - 72 - 2005 specifications.

Hillphoenix refrigerated display cases for sale in the United States meet or exceed department of energy 2017 efficiency requirements.

Numbers are based on standard case sizes. Consult engineering.



DLPF
(Remote)

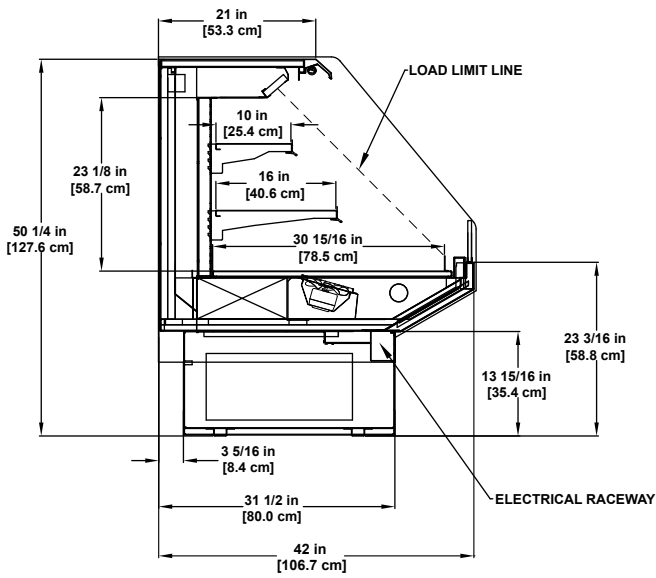

SMD PROFILE

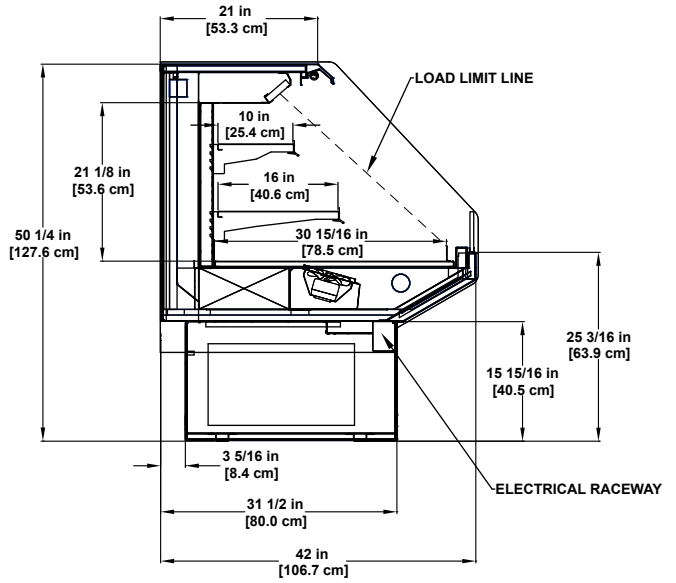

SSD PROFILE

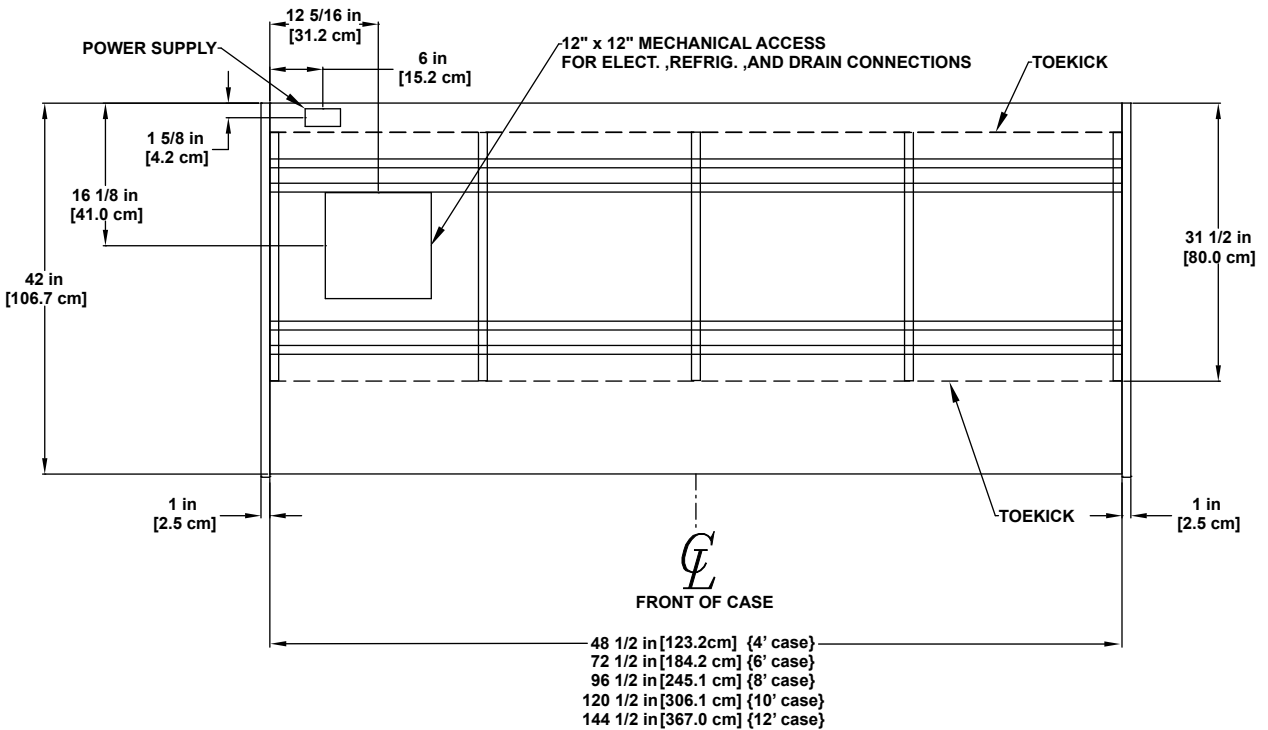

**SELF-SERVICE
SINGLE-DECK**

Bakery / Beverage / Cheese / Deli