

## Multi-Deck

Medium temperature merchandiser for beverage products.

# 05DM

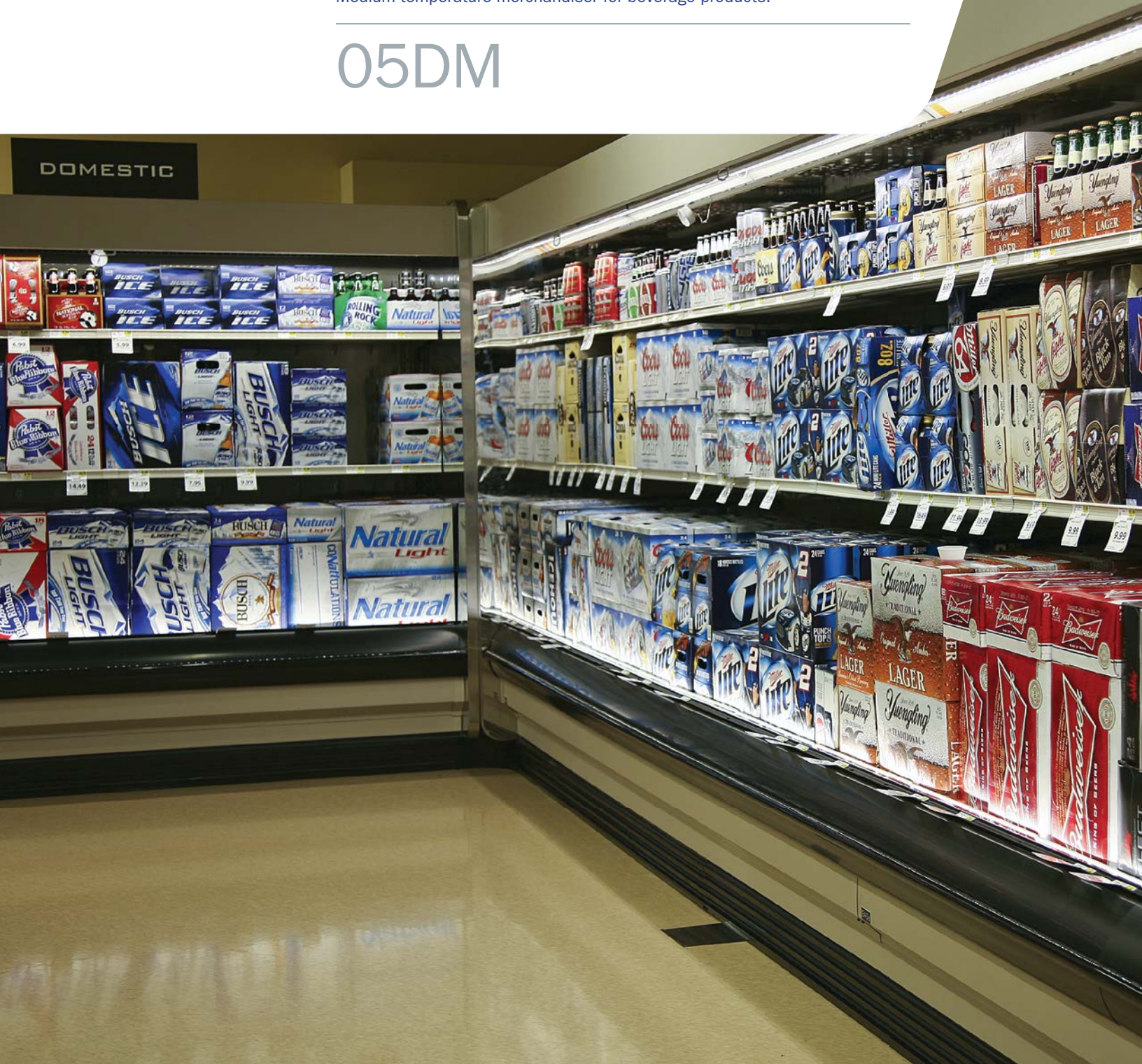

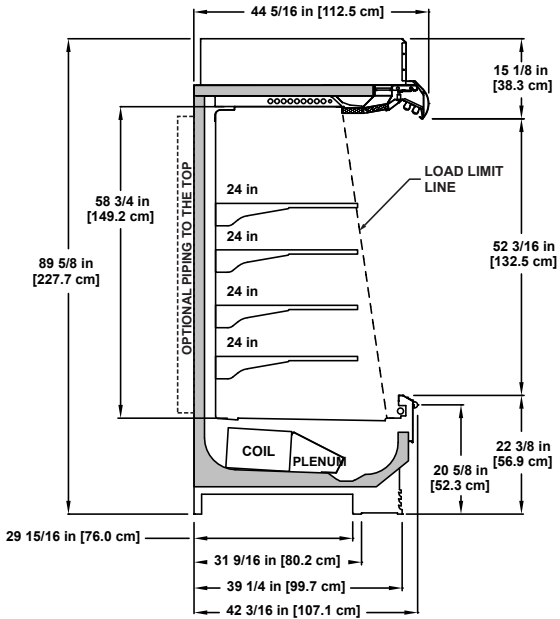

**Standard Lower Front Panel Design Options (18" shown)**

Consult Hillphoenix Engineering Reference Manual for other available heights.

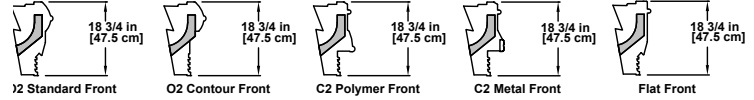

**Standard Cornice Options**

Consult Hillphoenix Engineering Reference Manual for premium cornice options.

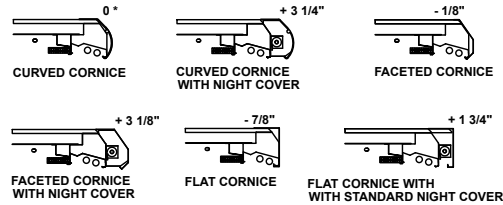

**Synerg-E® technology delivers unmatched energy efficiency without compromising the integrity of the perishable products being displayed.**

Please consult Hillphoenix Engineering Reference Manual for dimensions, plan views and technical specifications. Specifications subject to change without notice. Designed for optimal performance in store environments where temperature and humidity do not exceed 75°F and 55% R.H. Certified to UL 471 and ANSI/NSF Standard 7.

**Available Options**

- Available lengths: 4', 6', 8', 12'.
- Multiple, different front styles available.
- Multiple front sill heights available.
- Adjustable wire racks provide display flexibility.
- Custom Colors, Finishes, and Textures.
- Available in traditional direct expansion as well as Secondary Coolant versions.
- Narrow depth version available as ON5DM. Taller version available as O5DMH. Rear loading version available as O5DR.
- Exclusive Clearvoyant® LED Lighting System.

**Features and Benefits**

- Synerg-E Technology with NRGcoil™.
- Unique design ensures uniform case performance and lower average product temperatures with optimum energy efficiency.
- Standard Off Cycling defrost for cost-effective operation.
- Bottom-mounted NRGcoil and lift-up fan plenum for ease of maintenance.
- Seamless tank liner provides positive drain runoff and enhances sanitation.
- Removable castors for easy merchandiser unloading, movement and placement.
- Exclusive Clearvoyant® 2 LED Lighting System.



Conyers, GA USA  
844.591.5937  
hillphoenix.com

©2015 Hillphoenix, Inc.

DC-M05\_O5DM-Bv0215