

The logo for Hillphoenix, featuring the name in a bold, blue, sans-serif font.The logo for Dover Company, consisting of the word "DOVER" in a blue box followed by the word "COMPANY" in a smaller font.

White Paper

# CO<sub>2</sub> Booster System Technology Explained

*... and the Regulatory Impacts Driving Their Adoption*

## CO2 Booster System Technology Explained and the Regulatory Impacts Driving Their Adoption

Advances in technology have made the use of CO<sub>2</sub> as an environmentally friendly refrigerant for booster systems practical across a wide range of applications. Food retail operators have been taking advantage of this approach for both medium and low-temperature applications for some time now; but so far, CO<sub>2</sub> in transcritical industrial systems remains limited and many potential users only have a partial understanding of how the technology works. This discussion seeks to fill that void by explaining in general how CO<sub>2</sub> booster systems work, and in particular, the function of three main components of the system that make it a practical alternative to traditional refrigeration systems.

Before getting into the operation of CO<sub>2</sub> booster systems and their similarities to, and differences from, other types of refrigeration systems, it's worth understanding why they are, and will continue to be, increasingly more common. The changing regulatory environment governing the food retail and industrial refrigeration sectors is one major reason. A brief history of refrigerants helps to explain why.

Refrigerants can be seen as having gone through four generations of development since the middle of the past century. Beginning with chlorofluorocarbons (CFCs) that were originally brought into use in the late 1920s as a viable, nontoxic refrigerant (in normal concentrations) for use in large commercial applications. The use of CFCs expanded throughout the years to a wide range of industries and operations.

However, by the 1970s, it became widely recognized that these highly efficient compounds, that were also used as aerosol propellants, blowing agents in insulating foam manufacturing, fire retardants, solvents and other applications, had an extremely damaging effect upon the ozone layer which protects life on earth from harmful ultraviolet radiation.

This situation threatened not only human health, but also the security of the world's food supply with the potential of substantially reduced crop production worldwide as a result of their use. Eventually, science and wider societal attitudes had settled on the need to eliminate CFCs resulting in the Montreal Protocol, a global agreement to protect the ozone layer by phasing out ozone-depleting substances.

In response to the potentially burgeoning environmental crisis, governments and industry moved to adoption of the next generation of refrigerants, hydrochlorofluorocarbons (HCFCs). The addition of hydrogen to chlorofluorocarbon compounds resulted in somewhat less harmful refrigerants that most notably included R-22. Despite their lower ozone depletion potential (ODP), HCFCs came to be only an interim solution as they still contained chlorine which still had a detrimental effect on the ozone layer. As of 2020, no new refrigeration equipment can be produced to use R-22, and all production and import of it is scheduled to end.

The next generation of refrigerants to come after HCFCs, were hydrofluorocarbons (HFCs). The arrival of these compounds finally eliminated the threat from refrigerants to the ozone layer. The absence of ozone depleting chlorine (the first C in HCFC) in these refrigerants made the difference. HFCs are relatively nonflammable, chemically stable and nonreactive. Many are colorless, odorless gases that are currently used in a wide variety of applications such as commercial refrigeration and automotive air conditioning. Widely used ones include R-404A, R-134a, and R-410A and R-407C which could all be used to replace R-22 in the appropriate applications.

As awareness of the effects of refrigerants on the environment grew, a new threat from their use came into view with the realization that global warming would be yet another consequence. Heat-trapping gases, also known as greenhouse gases, released into the atmosphere have been shown to result in the phenomenon called climate change. Based on evidence in the fossil record and elsewhere, scientist have determined that the presence of greenhouse gases in the atmosphere today exceeds concentrations anytime in the past

800,000 years. The climate change that results from these heightened levels of greenhouse gases effects not just rising average temperatures, but shifting wildlife populations and habitats, rising sea levels, increases in extreme weather events and a range of other impacts.

The upshot of both recent legal and political developments, as well as international agreements and industry initiatives, is that, HFCs are set upon a path toward elimination from the world's major economies. China, Brazil and Africa have pledged to freeze the use of HFCs by 2024, and the U.S., at least administratively, is onboard with these changes. The Significant New Alternatives Policy (SNAP) program of the EPA, prioritizes the movement of users toward alternative refrigerants with zero ODP and lower greenhouse warming potential (GWP) numbers. In essence, this means turning from synthetic (i.e., HFCs) compounds to natural compounds. CO<sub>2</sub> is the leader in this movement with its use having spread throughout the industry.

The most significant advancements come in the form of CO<sub>2</sub> booster systems. At a most basic level of understanding, CO<sub>2</sub> booster systems are, in many ways, similar to traditional direct expansion systems. In fact, most refrigeration technicians will be familiar with the basic components that are shared between the two types of systems. Compressors, expansion valves, receivers and heat exchangers used on booster systems are similar to ones used on DX systems; however, there are some key differences.

The main difference between the two types of systems has to do with the thermodynamic properties of CO<sub>2</sub> as a refrigerant. For instance, CO<sub>2</sub> has a high coefficient of heat transfer making it very efficient compared to most other commonly used refrigerants. This quality places CO<sub>2</sub> systems as an excellent alternative to traditional systems from small-scale stores or pharmaceutical processing to large-scale supermarkets or production, distribution, and warehouse applications. Higher operating pressures for these systems, on the other hand, cause some potential adopters concern. CO<sub>2</sub>, for instance, has a saturated operating pressure of 407 psig at +20°F.

So, the question arises, how does a CO<sub>2</sub> booster system work? As previously mentioned, under most conditions CO<sub>2</sub> booster systems run the same as any other type of DX system. But unlike most other types of DX systems, in a booster system all of the refrigerant from the low-temperature compressors moves through the medium-temperature compressors. The low-temperature compressors discharge to the suction of the medium-temperature compressors. In other words, the low-temperature compressors serve as a booster to the medium-temperature compressors.

Suction gas from the low-temperature evaporators enters the low-temperature subcritical compressors at around 200 psig, well below the critical point for CO<sub>2</sub>. The low-temperature compressors discharge gas at about 425 psig, which then combines with the medium-temperature suction gas from the medium-temperature evaporators before entering the medium-temperature transcritical compressors. The medium-temperature discharge gas leaves the compressors, depending on ambient conditions, anywhere from 560 psig to as much as 1450 psig, which is above the critical point for CO<sub>2</sub> (which is 88°F and 1055 psig.)

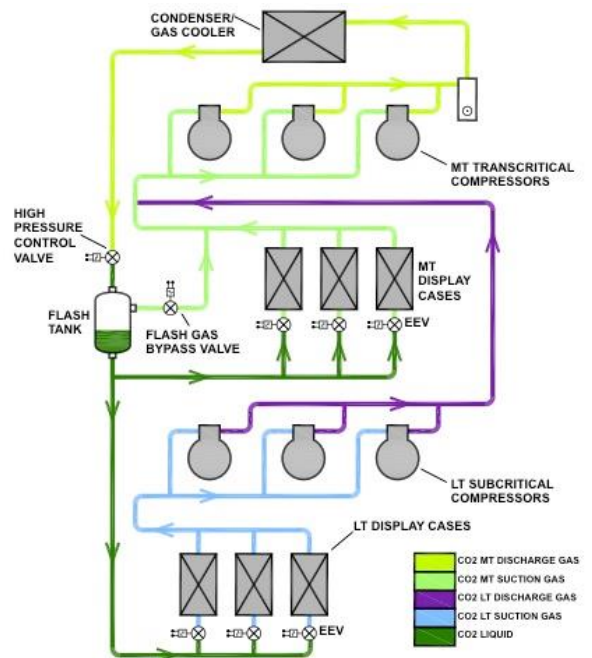

Figure 1: Simplified CO<sub>2</sub> Booster System Piping Diagram

During cool ambient conditions, the compressors discharge at the lower end of that range; however, with increases in the ambient temperature, the discharge pressure of the compressors also rises. Under warmer conditions, the discharge pressure can increase to 1450 psig, noticeably higher than for other types of systems.

The system begins to operate in the transcritical range when higher ambient conditions cause the pressure to rise above 1055 psig. At this point, the CO<sub>2</sub> can no longer be condensed, and three components of the system are specifically designed to handle the increased pressures

when these conditions come into play, as well as more moderate conditions that the system might be most often operating under depending on the kind of climate where the system is installed.

CO<sub>2</sub> booster systems make use of some special components in order to accommodate the higher pressures the systems are sometimes subject to. Along with medium-temperature compressors designed to handle the higher pressures of CO<sub>2</sub> in its transcritical state, all the piping and valves on the system are also rated for higher pressures. (One advantage is that due to the high volumetric capacity of CO<sub>2</sub>, smaller diameter pipe can be used than would be needed for other types of systems of similar size. Piping on the high side of the system, however, must be either carbon or stainless steel, or copper-iron alloy tube rated to at least 120 bar.) Beyond these requirements, the specific components the system relies on are a high-pressure control valve, a flash-gas bypass valve, and a type of condenser that, under higher ambient conditions, operates as a gas cooler.

As with most other types of systems, controllers for booster systems are available from a number of manufacturers. The controller on booster systems maintains the optimal pressure in the gas cooler when the system is operating in the transcritical range so as to maximize the system's performance. This method of control provides optimum COP (coefficient of performance).

Two other components common to other types of refrigeration systems that are also used on booster systems for food retail applications are case controllers and electronic expansion valves (EEVs). The case controllers and EEVs for booster systems are specifically designed to handle the higher pressures at which they operate in order to optimally control and maintain super heat at the outlet of the coils in the cases and walk-ins. The EEVs can be a pulse valve or stepper valve type.

## Condenser/Gas Cooler

This component usually works the same way a condenser does in a conventional DX system. Operating under ambient conditions, medium-temperature discharge gas enters the unit and rejects heat to the outside air as it passes through the coils.



The main difference between it and a conventional condenser is that when the warmer ambient conditions occur, and the system begins operating in the transcritical range of CO<sub>2</sub> where no saturated state change can occur, it remains a supercritical gas (or fluid). The fluid at this point exists above the pressure of the two-phase (liquid/vapor) regime. Consequently, the controller has to use a different algorithm when the system operates supercritically.

This last point is a key distinction. Under transcritical conditions, the discharge gas enters the condenser/gas cooler as a supercritical fluid and stays that way all the way through the unit to next special component in the system, the high-pressure control valve. No condensing of the gas at this point takes place as in a conventional condenser. During cooler ambient conditions, however, the unit then works just like a condenser in a typical DX system. The condenser/gas cooler design is optimized to achieve high-performance, even at high ambient temperatures when the system is operating in the transcritical range.

Adiabatic condensing can be used in warmer climates to extend the efficiencies of the system during transcritical operation. This approach allows the system to continue condensing at lower wet bulb temperatures than the ambient dry bulb temperature.

These types of condensers use the evaporation process to lower the temperature of the ambient air as it flows through a set of water-moistened pads before reaching the condenser's coils. The resulting cooler air then absorbs heat from the dry coils.

A minimum gas temperature out of the gas cooler is maintained through capacity control of the condenser fans. This typically works through use of variable speed fans and fan steps. Fixed speed, staged fans can also be used. On units with variable speed fan control, the condenser/gas cooler fan motors are controlled in parallel so that they all operate at the same speed. The variable speed-controlled fans in a sense run as a single big fan, ramping up and down and cycling on and off together instead of individually. The optimum reference for fan control is a user-defined, minimum temperature difference between the air temperature and the CO<sub>2</sub> gas temperature measured at the outlet of the gas cooler.

When low ambient temperatures occur, the fans in the condenser/gas cooler (in most applications) shut off. Natural convection alone extracts enough heat from the CO<sub>2</sub> vapor to condense into a subcooled liquid. The high-pressure control valve determines the amount of subcooling that occurs under these conditions, as it does whenever the system is operating subcritically.

### **High-Pressure Control Valve**

CO<sub>2</sub> leaving the condenser/gas cooler feeds to a high-pressure control valve that expands the CO<sub>2</sub> into an intermediate pressure receiver called a flash tank (described below). The gas enters the high-pressure control valve at up to 1450 psig, depending on ambient conditions, and exits it at 540 psig as determined by the pressure in the flash gas tank which is controlled by the flash gas bypass valve (described later). The valve is designed to work under all operating conditions (both subcritical and transcritical) somewhat like a holdback valve in order to maintain optimum pressure through the gas cooler for the most efficient operational performance of the system in either state. It controls pressure in the condenser/gas cooler





maximizing the compressor coefficient of performance (COP). The maximum working pressure for the valve is 2030 psig.

### **Flash Gas Bypass Valve**

The expanded gas leaving the high-pressure control valve flows into the flash tank at around 540 psig. The flash tank performs the same function as that of a receiver on a conventional DX system. But, on transcritical booster systems, the flash tank is equipped with a flash gas bypass valve that sends vapor from the tank to the medium-temperature suction lines where it joins the gas from the medium-temperature evaporators returning to the medium-temperature compressors. Operational pressure is maintained in the flash tank as a result.



### **Conclusion**

The challenges facing food retail and industrial refrigeration make the rational for moving to environmentally friendly CO<sub>2</sub> convincing. CO<sub>2</sub> booster systems offer significant advantages. Since their introduction to North America early in the last decade, the number and types of applications for which they can be used has multiplied making them suitable for a wide range of refrigeration requirements. The design of these systems that allows them to work most of the time the same way that traditional DX systems do, makes them easy to install and operate. CO<sub>2</sub> provides an alternative to traditional refrigerants that places users on a path toward greater sustainability and higher levels of efficiency.