

Single Deck Utility Case

Self-service mobile case features dual temp flexibility with the flip of a switch: promote low temp frozen foods or ice cream one day, then medium temp items the next.

OSOIZA

Self-Contained Mobile - Dual Temperature Merchandiser



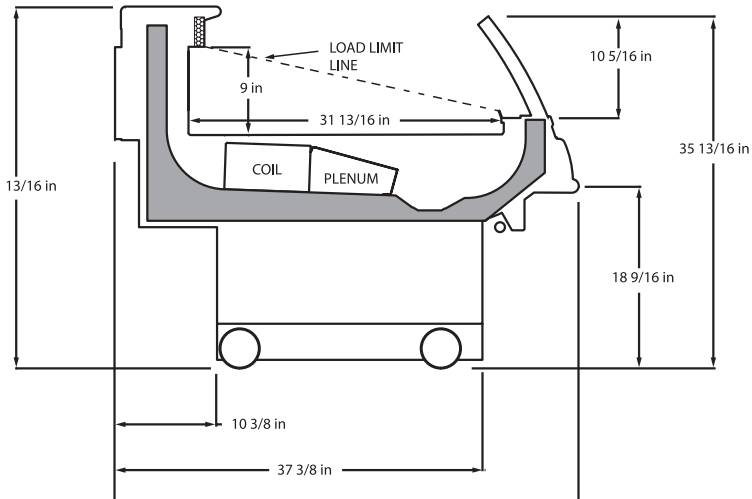

Please consult Hillphoenix Engineering Reference Manual for dimensions, plan views and technical specifications. Specifications subject to change without notice. Designed for optimal performance in store environments where temperature and humidity do not exceed 75°F and 55% R.H. Certified to UL 471 and ANSI/NSF Standard 7.

Available Options

- Elegant style features curved tempered glass with an 11" view and a front sill height of only 34" for easy product reach.
- Ample 12" rear sill available in stainless steel or custom color.
- Self-contained condensing unit carries coolant within the base, eliminating field piping.
- Digital microprocessor-controlled thermostat can be programmed at precise, consistent temperatures for a multitude of medium and low temp applications.
- Change between medium and low temp applications with single switch conversion.
- Optional ice pans available for seafood display.
- Optional double-drain (with plumbing valve for connection to existing floor drain) promotes easy on-the-spot clean-up.
- Durable castors offer precise height adjustment and lock merchandiser in place until Solid insulated ends available either mirrored or custom color. If you need to reposition.
- Powered by 115 volt/20 amp dedicated twist lock outlet.
- Solid insulated ends available either mirrored or custom color.
- ECM energy-efficient fan motors available.

Features and Benefits

- Unique design ensures uniform case performance and lower average product temperatures with optimum energy efficiency.
- All-steel construction for increased life span and structural integrity.
- Seamless tank liner provides positive drain runoff and enhanced sanitation.
- Integrated two-part polymer bumper system provides unparalleled protection and durability.

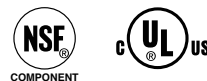

Hillphoenix
A DOWNEY COMPANY

Conyers, GA USA
770.285.3057
hillphoenix.com

©2012 Hillphoenix, Inc.

DC-SC12_OSIOZAv0912