

# Service Single-Deck

Refrigerated gravity coil merchandiser with fixed vertical glass for deli, meat and seafood.

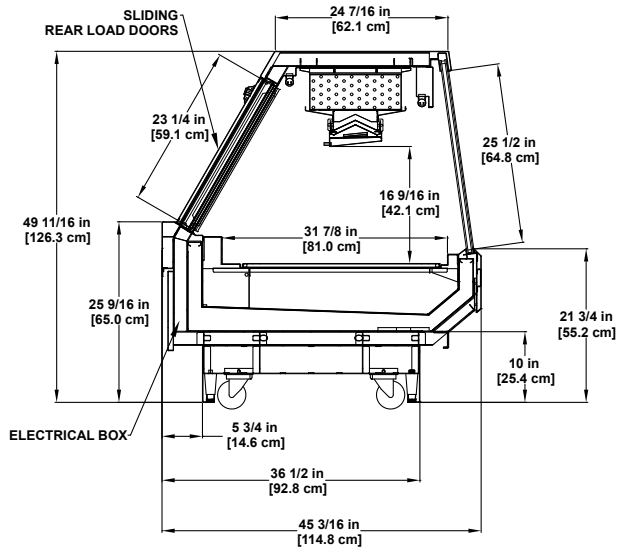

Model SGM  
Service Single-Deck



Please consult Hillphoenix Engineering Reference Manual for dimensions, plan views and technical specifications. Specifications subject to change without notice. Designed for optional performance in store environments where temperature and humidity do not exceed 75 degrees and 55% R.H. Certified to UL 471 and ANSI/NSF Standard 7.

### Base Model Features

- C-frame with Bullet Leg Construction.
- Standard 50”H with 10”H base frame height.
- Exterior: Painted metal, including lower front panel above base.
- Stainless steel base trim, front and sides.
- Stainless steel exterior trim.
- Painted metal outside back and rear base trim.
- Stainless steel top sill.
- Clear rear load doors with black frames.
- 26”H - 7/8” thermopane, insulated regular-glare flat fixed front full length glass.
- Stainless steel interior.
- Interior trim to match interior.
- Black plastic coil covers with fixed black wire rack.
- Clearvoyant LED dual canopy lighting.
- Rear electrical box mounted behind the lower rear panel, customer left.
- Oversized gravity coil meat model.
- Solar digital thermometer.
- Remote DX refrigeration package.

### Available Options

- Available lengths: 4’, 6’, 8’ and 12’.
- Case heights available: 52” and 54”.
- Alternate flexible base heights include: 8”, 10”, 12” and 14”H.
- Extruded polymer base trim.
- Painted metal base trim.
- Master with nose bumper.
- Cart bumper (for flat front profile).
- Exterior stainless steel finish.
- Solid surface or stone case top.
- Integrated case top scale stand.
- Adjustable scale stand.
- White plastic coil covers.
- Adjustable wire racks.
- Reflective rear load doors.
- 30”H - 7/8” thermopane, insulated regular-glare flat fixed front full length glass.
- Rear flip-up work boards.
- ISO outlet/CON outlets.
- Solid interior mirror polish stainless steel, thermal glass divider or glass ends.
- Remote glycol or CO<sub>2</sub> refrigeration packages.



Dover Food Retail  
Conyers, GA USA  
844.591.5937  
hillphoenix.com

©2018 Hillphoenix, Inc.



an overseas company