

**Hillphoenix**

a **DOVER** company

**SSD-LT  
Gelato**

## Service Single-Deck

Low temp refrigerated gelato merchandiser with curved or flat fixed glass.



Photo may depict options not included on standard models.

## Model SSD-LT Gelato Service Single-Deck

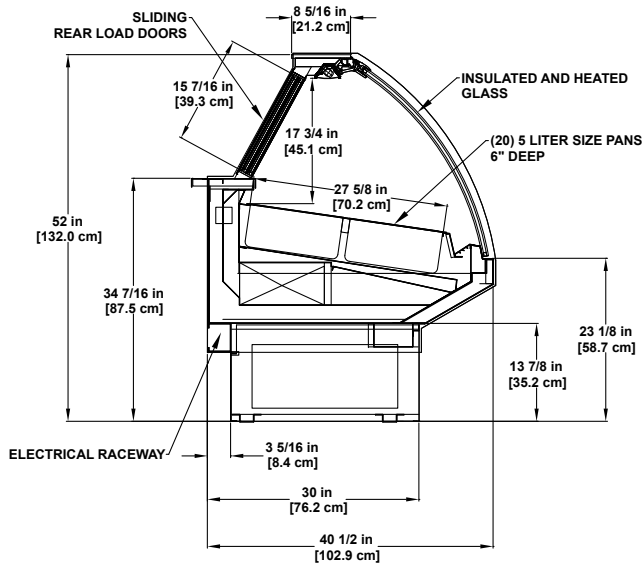

Please consult Hillphoenix Engineering Reference Manual for dimensions, plan views and technical specifications. Specifications subject to change without notice. Designed for optional performance in store environments where temperature and humidity do not exceed 75 degrees and 55% R.H. Certified to UL 471 and ANSI/NSF Standard 7.

### Base Model Features

- Sled runner base construction.
- Standard 52"H and 40-1/2"D.
- Standard 13-7/8"H base.
- Painted metal exterior.
- Stainless steel exterior trim.
- Painted base trim to match exterior; front & sides.
- Stainless steel outside back, rear toekick, case top and rear work ledge.
- Insulated, reflective rear load doors.
- Heated, insulated regular-glare curved lift front glass.
- Stainless steel interior and trim.
- Clearvoyant LED canopy lights.
- Fixed, angled stainless steel deck to accommodate up to 6"D standard U.S. hotel pans (pans are not included).
- Rear electrical raceway.
- Hard wire power connection.
- 2" dial thermometer.
- Low-temp GE fans.
- Electronic refrigeration controller.
- Remote DX refrigeration package.

### Available Options

- Available in 4' and 6' case lengths.
- Glass or mirror polished interior end panels.
- Exterior standard grade laminate.
- Solid surface or stone case top.
- Exterior stainless steel finish.
- Mirror polish stainless inside back.
- Painted exterior and end panel trim.
- Painted outside back finish.
- Cart bumper.
- Alternative case thermometer.
- Remote glycol or CO<sub>2</sub> refrigeration packages.



Dover Food Retail  
Conyers, GA USA  
844.591.5937  
hillphoenix.com

©2018 Hillphoenix, Inc.

**Hillphoenix**  
a DOVER company