

Hillphoenix

a **DOVER** company

SSFM-RG

Service Single-Deck

Refrigerated gravity coil merchandiser for meat and seafood with flat lift-glass.



Photo may depict options not included on standard models.

Model SSFM-RG
Service Single-Deck

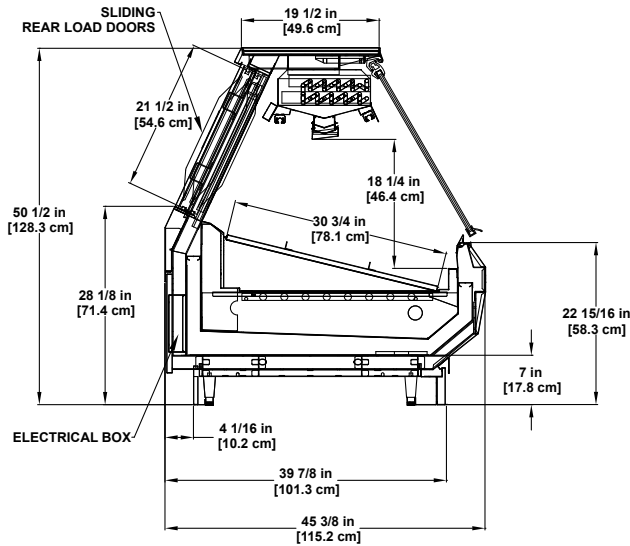

Please consult Hillphoenix Engineering Reference Manual for dimensions, plan views and technical specifications. Specifications subject to change without notice. Designed for optional performance in store environments where temperature and humidity do not exceed 75 degrees and 55% R.H. Certified to UL 471 and ANSI/NSF Standard 7.

Base Model Features

- C-frame with bullet leg construction.
- Standard 50-1/2”H with 7”H base frame height.
- Exterior: Painted metal, including lower front panel above base.
- Stainless steel base trim, front and sides.
- Stainless steel exterior trim.
- Painted metal outside back and rear base trim.
- Stainless steel top sill.
- Clear rear load doors with black frames.
- 5/8” thermopane, insulated regular-glare flat lift front glass.
- Gray glass gasket, wipe and glass handle.
- Stainless steel interior and trim.
- Black plastic coil covers with fixed black wire rack.
- Clearvoyant LED dual canopy lighting.
- Rear electrical box mounted behind the lower panel.
- Gravity (large) with serpentine assist meat model.
- Solar digital thermometer.
- Remote DX refrigeration package.

Available Options

- Available lengths: 4’, 6’, 8’ and 12’.
- Case heights available: 52-1/2” and 54-1/2”.
- Alternate flexible base heights include: 9” and 11”H.
- Extruded polymer base trim.
- Painted metal base trim.
- Master with nose bumper.
- Cart bumper (for flat front profile).
- Exterior stainless steel finish.
- Solid surface or stone case top.
- Integrated case top scale stand.
- Adjustable scale stand with ISO outlet.
- White plastic coil covers.
- Adjustable wire racks.
- Reflective rear load doors.
- Black glass gasket, wipe and glass handle.
- Rear flip-up work boards.
- CON outlets.
- Solid interior mirror polish stainless steel, thermal glass divider or glass ends.
- Remote glycol or CO₂ refrigeration packages.
- (1)12” stainless steel upper shelf.



Dover Food Retail
 Conyers, GA USA
 844.591.5937
 hillphoenix.com

©2018 Hillphoenix, Inc.

