

Service Multi-Deck

Refrigerated deli merchandiser with vertical fixed glass.

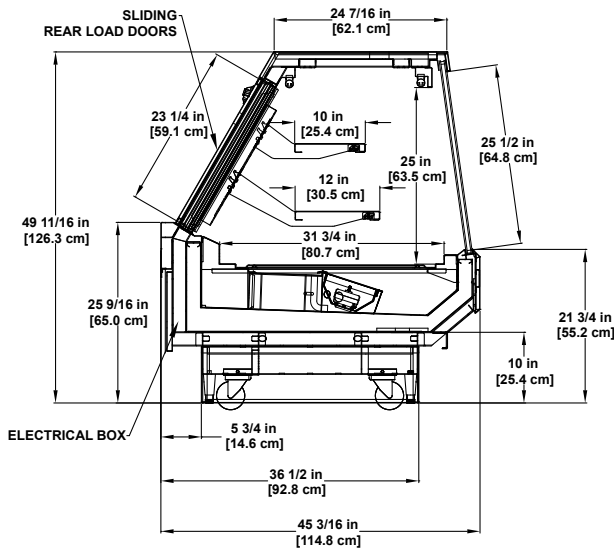

Model SSM-R
Service Multi-Deck



Please consult Hillphoenix Engineering Reference Manual for dimensions, plan views and technical specifications. Specifications subject to change without notice. Designed for optional performance in store environments where temperature and humidity do not exceed 75 degrees and 55% R.H. Certified to UL 471 and ANSI/NSF Standard 7.

Base Model Features

- C-frame with bullet leg construction.
- Standard 50”H with 10”H base frame height.
- Exterior: Painted metal, including lower front panel above base.
- Stainless steel base trim, front and sides.
- Stainless steel exterior trim.
- Painted metal outside back and rear base trim.
- Stainless steel top sill.
- Clear rear load doors with black frames.
- 26”H - 7/8” thermopane, insulated regular-glare flat fixed front full length glass.
- Black painted metal interior.
- Interior trim to match interior.
- Black plastic coil covers with fixed black wire rack.
- Clearvoyant® LED dual canopy lighting.
- Rear electrical box mounted behind the lower rear panel, customer left.
- Blower deli model.
- Solar digital thermometer.
- Remote DX refrigeration package.

Available Options

- Available lengths: 4’, 6’, 8’ and 12’.
- Case heights available: 52” and 54”.
- Alternate flexible base heights include: 8”, 10”, 12” and 14”H.
- Extruded polymer base trim.
- Painted metal base trim.
- Master with nose bumper.
- Cart bumper (for flat front profile).
- Interior and exterior stainless steel finish.
- White or other painted metal interior finish.
- Solid surface or stone case top.
- Integrated case top scale stand.
- Adjustable scale stand with ISO outlet.
- (1) row each 10” and 12” black painted metal shelving with PTM.
- Clearvoyant LED undershelf lighting.
- Z step or slant risers.
- White plastic coil covers.
- Adjustable wire racks.
- Reflective rear load doors.
- 30”H - 7/8” Thermopane, insulated regular-glare flat fixed front full length glass.
- Rear flip-up work boards.
- CON outlets.
- Solid interior mirror polish stainless steel, thermal glass divider or glass ends.



Dover Food Retail
Conyers, GA USA
844.591.5937
hillphoenix.com

©2018 Hillphoenix, Inc.

