

Glass Door Reach-In

Low temperature frozen food and ice-cream case.

VNRZ



CLARITY™ reach-in merchandisers customized with the ideal frame and door options deliver superior performance for every need. Multiple sizes and configurations help store merchandisers provide unique refrigeration options and enhanced product displays to create a superior shopper experience.

CLARITY
Reach-In Merchandisers from Hillphoenix

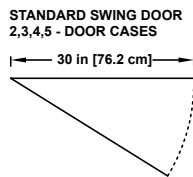
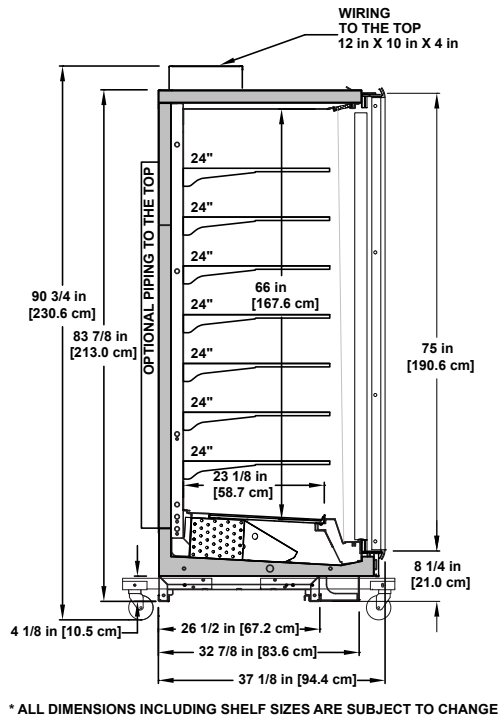

Please consult Hillphoenix Engineering Reference Manual for dimensions, plan views and technical specifications. Specifications subject to change without notice. Designed for optimal performance in store environments where temperature and humidity do not exceed 75°F and 55% R.H. Certified to UL 471 and ANSI/NSF Standard 7.

Available Options

- 2, 3, 4 & 5 door with 30" standard swing doors.
- Available frames: 101 LE.
- Available doors: ELM D, ELM H & Infinity 90.
- Available door colors: silver satin, polished aluminum, black or glass infinity edge.
- Shelving: 22 or 24" in the narrow version.
- Electric or hot gas defrost.
- Energy efficient fan motors are standard.

Features and Benefits

- 75" tall door, coupled with 8" ultra-low front, maximizes product visibility and merchandising versatility.
- 66" Interior front facings without any POG restrictions.
- Bottom-located refrigeration components facilitate serviceability and allow for full top shelf merchandising.
- Medium and low temp models match for consistency in store design.
- For a wall of infinity edge glass doors, choose the Vista E doors on your MT cases and the Infinity 90 on your LT cases.
- Great product visibility & merchandising options.
- Allows for petite customers to reach merchandise on the top shelf.
- Enhance your planogram design options with added flexibility and versatility.
- Low (8") front sill to maximize merchandise opportunities.
- With easy to design POG's, with no restrictions in the 66" with refrigeration components located in the tank below the deck pan, allows for the merchandise to take center stage.
- Review your Clarity Brochure for all door & frame features.
- Variety of door rail profiles, finishes and handles available.
- Polymer or metal end trim.
- Innovative LED lighting choices increase visual impact of product while reducing energy consumption and released heat in case.
- Motion sensors for additional energy savings available.
- Removable castors for easy merchandiser unloading, movement, and installation.



Hillphoenix
a DOWER COMPANY

Conyers, GA USA
844.591.5937
hillphoenix.com

©2015 Hillphoenix, Inc.

DC-R01_VNRZv0415