

Hillphoenix

a **DOVER** company

**JNRZ(B)HSA
JNRZ(B)HA**

Self-Contained Glass Door Reach-In

Medium and low temperature merchandisers for dairy, deli, bakery, meat, beverage, frozen food and ice cream.



CLARITY® reach-in merchandisers

customized with the ideal frame

and door options deliver superior performance for every need.

Multiple sizes and configurations

help store merchandisers provide unique refrigeration options

and enhanced product displays

to create a superior shopper experience.

CLARITY®

Reach-In Merchandisers from Hillphoenix

Photo may depict options not included on standard models.

Model JNRZ(B)HSA/JNRZ(B)HA
Self-Contained Glass Door Reach-In

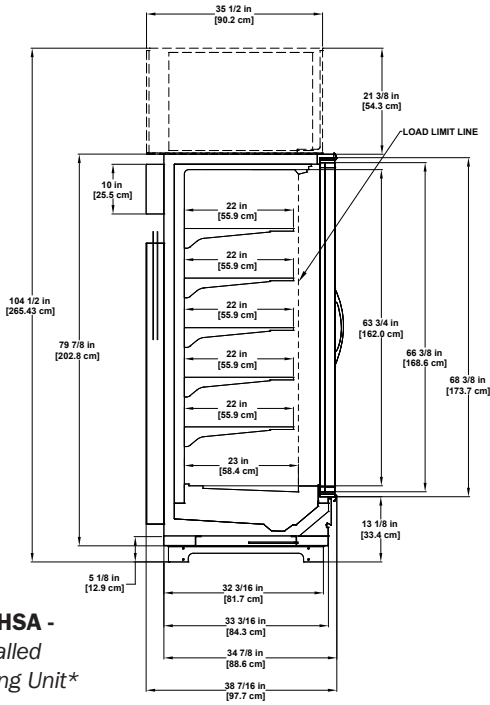

JNRZ(B)HSA -
 Field Installed
 Condensing Unit*

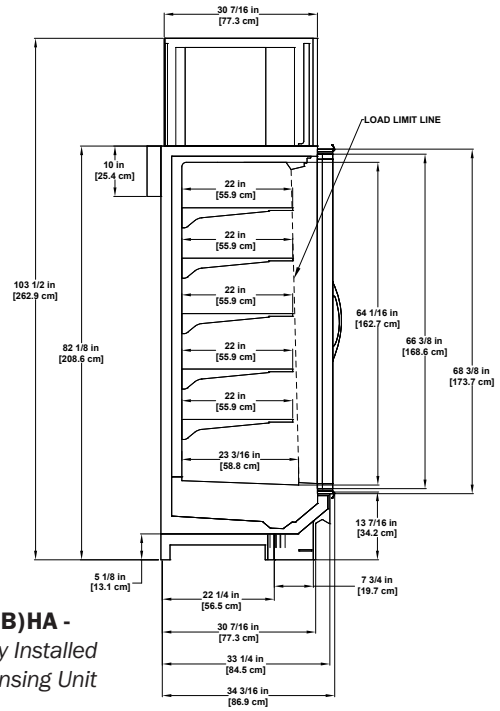

JNRZ(B)HA -
 Factory Installed
 Condensing Unit

*Specialized Base Frame:
 • Case fits through 80" doorway with shipping undercarriage removed.
 • 2" lifting brackets (installed) & 3.25" ship loose risers combine for 5" base frame once installed.
 • Drain traps ship loose.

Please consult Hillphoenix Engineering Reference Manual for dimensions, plan views and technical specifications. Specifications subject to change without notice. Designed for optional performance in store environments where temperature and humidity do not exceed 75 degrees and 55% R.H. Certified to UL 471 and ANSI/NSF Standard 7.

Base Model Features

- Bottom-located refrigeration components facilitate serviceability and allow for full top shelf merchandising.
- Modular interior component design allows easy access to the coil, fans and drain for ease of maintenance.
- Proprietary Synerg-E® technology with NRGcoil™ and energy efficient fan motors ensure uniform case performance and lower average product temperatures with optimum energy efficiency.
- Low temp and medium temp cases line up seamlessly for consistent in-store design.
- Innovative Anthony® Optimax LED lighting for energy efficiency and a stunning merchandise display.
- 22" shelves for maximum display capacity.
- 63-3/4" front facings with no planogram restrictions.
- Removable casters for easy merchandiser unloading, movement and installation.

Available Options

- 2, 3, 4 & 5 Door with 30" standard swing doors.
- Variety of door rail profiles, finishes and handles.
- Low temp doors - Anthony® Infinity 90, ELM-D, ELM-H.
- Medium Temp doors - Anthony Infinity 90 & ELM-D.
- Modbus controller for ease of use.
- Motion sensors for additional energy savings.
- Cases can ship with the condensing unit factory or field installed:
 - Factory installed condensing units (JNRZHA, JNRBHA) ship fully piped and plumbed with single-point wiring for easy installation.
 - Field installed condensing units (JNRZHSA, JNRZHSA) ship with minimal assembly required and incorporate a special base frame option allowing it to fit through an 80" door. And a loading dock is not required because the design incorporates a special low base on wheels and a condensing unit that is installed on site.
- Polymer or metal end trim.

STANDARD SWING DOOR
 2, 3, 4 & 5 DOOR CASES

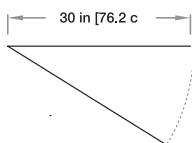

Door Options

Consult Hillphoenix Engineering Reference Manual for more available options.

Casters add 2 1/4" to shipping height.



Dover Food Retail
 Conyers, GA USA
 844.591.5937
 hillphoenix.com



©2018 Hillphoenix, Inc.