

**Hillphoenix**

a **DOVER** company

**The  
SFC  
Group**

*Solutions for  
convenience sake*



**VNRBS**

**Medium Temperature Glass Door Reach-In**

Small-store format, refrigerated reach-in merchandiser for beverage and dairy.

## VNRBS - Medium Temperature Glass Door Reach-In



### Base Model Features

- Available lengths – 2, 3, 4 & 5 doors.
- 5” baseframe.
- Custom color, flat front panel.
- 1” black bumper.
- Metal-louvered kick plates.
- Square end panels with black PVC trim.
- Black interior with black polymer deck pans.
- Black flat bottom wire rack with 3” lip and black PVC PTM.
- (4) rows 24”x30” matte black solid shelves with black PVC PTM.
- Black Anthony Vista door frames w/Optimax Pro high-output 3500K LEDs, LH swing.
- Black Anthony I60 doors with Vista Arch handles, 30”LH swing doors.
- Customer-provided light controls.
- Solar digital thermometer.
- Refrigeration:
  - R448A DX refrigerant type.
  - TXV balance port sweat.
  - Heat exchanger.
  - Refrigeration lines piped to the bottom.
  - Hand valve.
  - EBM high-efficiency fan motors.
  - Time-off defrost.
- Conforms to UL Standard 471, NSF Standard 7 and CAN/CSA C22.2.

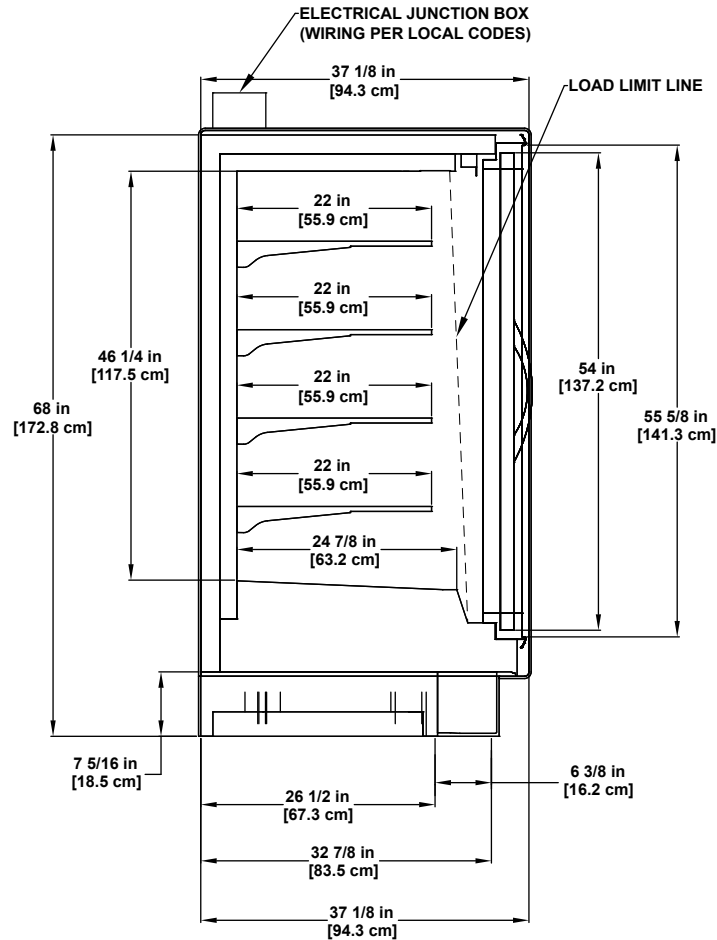

2017  
**DOE**  
COMPLIANT

Please consult Hillphoenix Engineering Reference Manual for dimensions, plan views and technical specifications. Specifications are subject to change without notice. Certified to UL 471 and ANSI/NSF standard 7.

Designed for optimal performance in store environments where temperatures and humidity do not exceed 75°F and 55%R.H.

## Available Options

- Brushed stainless front end trim (S3).
- Black Anthony 101 door frames w/Optimax Pro high-output 3500K LEDs, LH swing.
- Black Anthony ELMD doors with Vista Arch handles, 30" LH swing doors.
- 4000K vertical lights available.
- White case interior.
- 4 rows of shelving.
- Top wiring.
- R407A refrigerant.
- Top piping.
- Temperature control TStat.
- Temperature probe.

## Fast Facts...

- Standard high-efficiency ECM fan motors for optimum energy savings.
- 54" tall door, coupled with ~8" ultra-low front, maximizes product visibility and merchandising versatility.
- Bottom-located refrigeration components facilitate serviceability and allow for full top shelf merchandising.
- Refrigeration component placement below the deck pan ensures no plan-o-gram restrictions and maximizes merchandising visibility.
- All-steel construction for increased life span and structural integrity.
- Seamless tank liner provides positive drain runoff and enhanced sanitation.
- Removable castors for easy merchandiser unloading, movement and installation.

**Hillphoenix**

a **DOVER** company

2016 Gees Mill Road  
Conyers, GA 30013  
844.591.5937  
[www.hillphoenix.com](http://www.hillphoenix.com)

©2018 Hillphoenix, Inc.