



Hill PHOENIX
REFRIGERATION SYSTEMS

Second Nature CO₂

SNMT2LX

*Introducing CO₂
Refrigeration Technology*

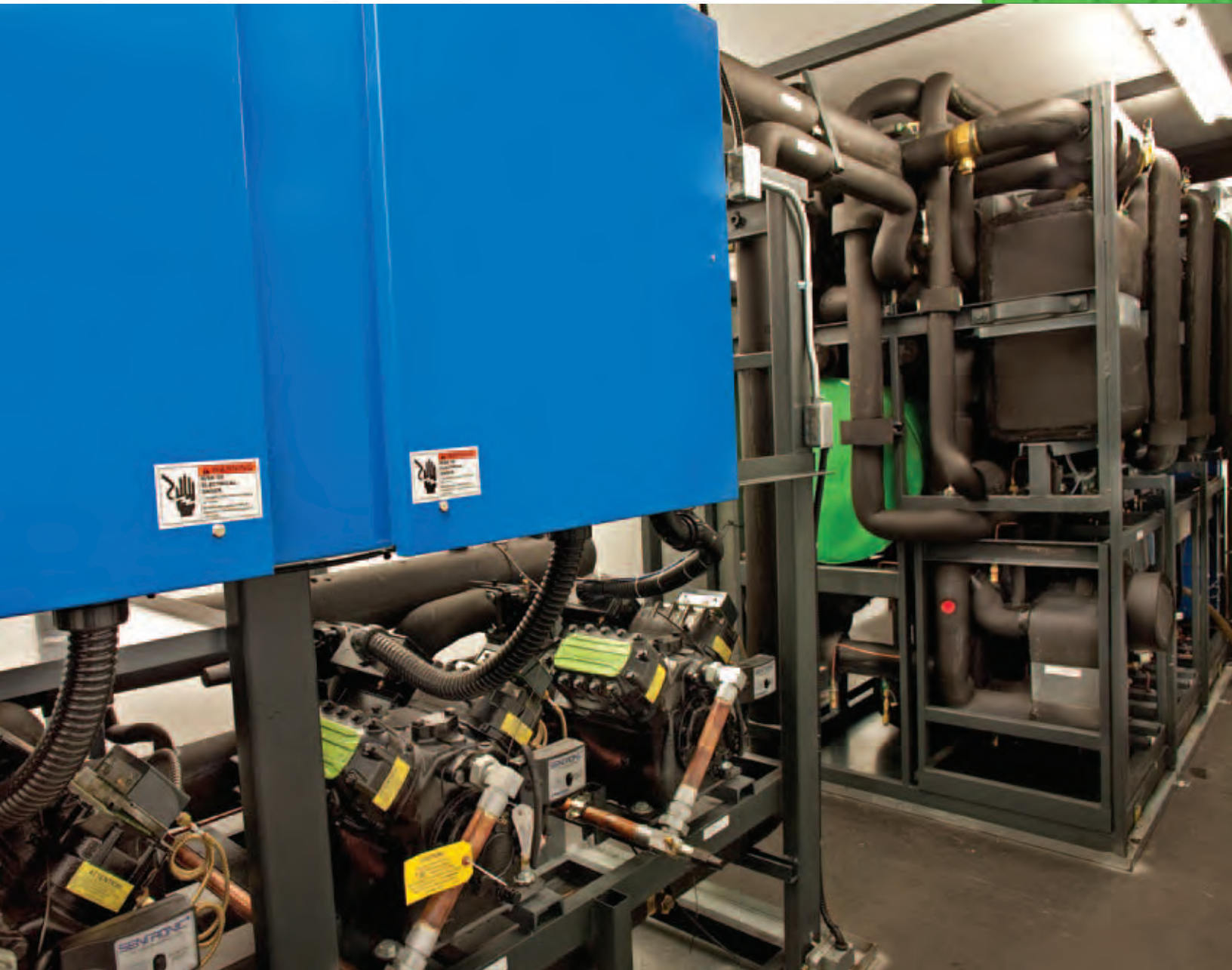

Key System Benefits

- Energy efficient design saves operating costs
- Low cost natural refrigerant widely available
- Very low global warming potential
- Smaller copper piping lowers cost and carbon footprint
- System components widely available for ease of maintenance when required



System Operation and Features

- Second Nature® MT2LX system utilizes CO₂ as a secondary coolant for the medium-temperature system and CO₂ as a direct expansion cascade refrigerant for the low-temperature system.
- A CO₂ pump, typically installed as a primary pump with a parallel backup pump, delivers liquid CO₂ through the supply distribution piping to both the low and medium-temperature evaporators.
- Low-temperature evaporators designed specifically for CO₂ direct expansion operation.
- CO₂ as a direct expansion refrigerant with better heat transfer properties compared to conventional HFCs.
- Medium-temperature evaporators designed for fully-flooded CO₂ secondary operation.
- The low-temperature display cases and freezers are equipped with the Hill PHOENIX Smart Valve™ system with EEV's for steady, automatic control of superheat leaving the evaporators.
- Medium-temperature display cases and coolers are equipped with solenoid valves which control the flow of CO₂ into the evaporators.

Benefits of Using Second Nature CO₂ Refrigeration Technology

- CO₂ is considered a natural refrigerant with very low global warming potential (GWP=1).
- CO₂ is inexpensive refrigerant compared with HFC and is widely available.
- An excess of 70 percent reduction in HFC refrigerant charge can be achieved. The entire primary refrigerant charge is confined to the machine room and condenser to enable simple leak detection and servicing.
- The piping system utilizes a modified-loop copper piping system - CO₂ lines are typically one to two sizes smaller than traditional DX piping systems.

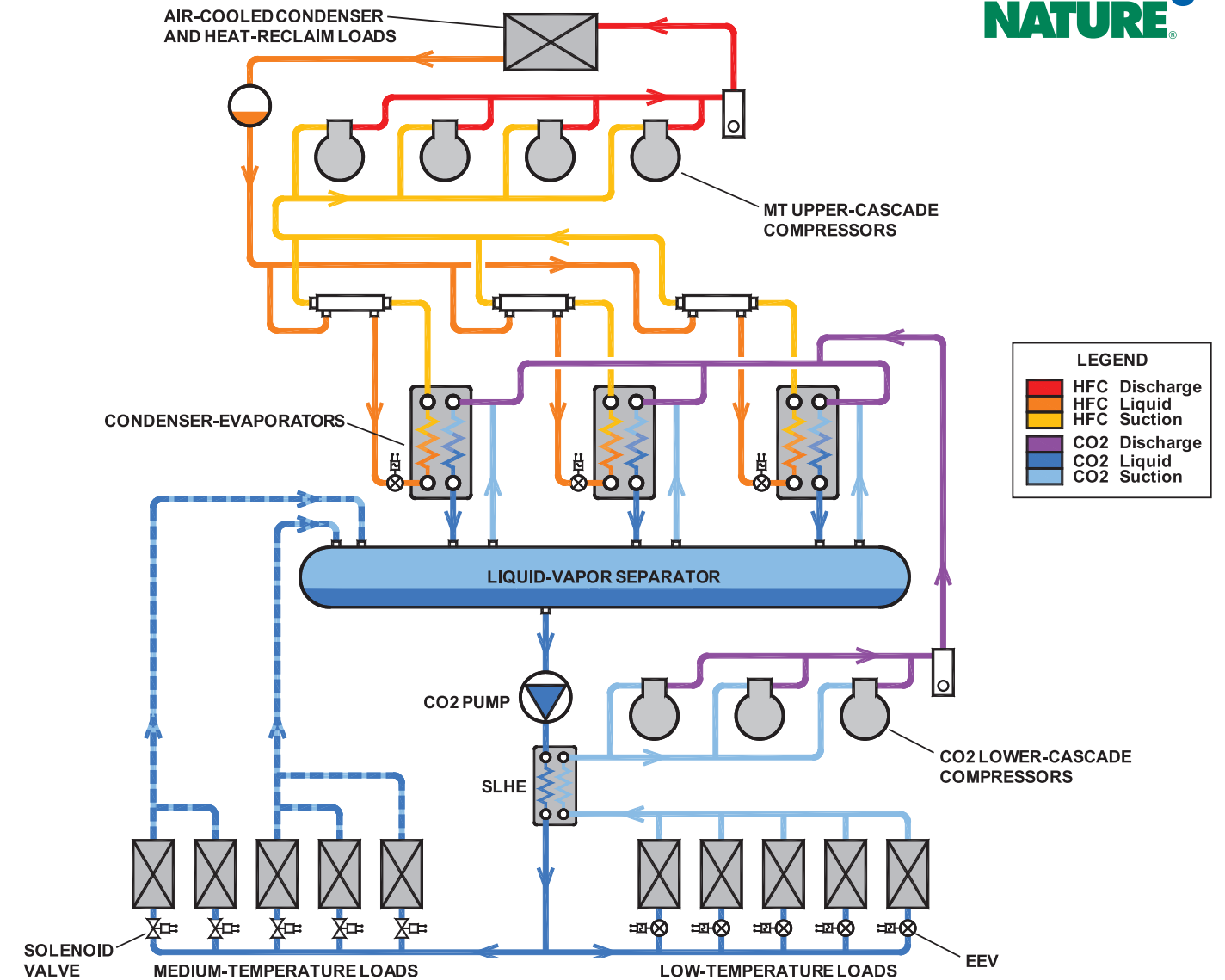

System Options

- Excellent material compatibility – most equipment for commercial refrigeration can be used .
- Medium-temperature system uses CO₂ as a two-phase secondary coolant taking advantage of CO₂'s high latent heat capacity – this dramatically lowers flow rates (typical 90% reduction) and pumping power compared to conventional secondary fluids (e.g. glycols).
- System energy performance equivalent or better than conventional HFC systems.
- Low-temperature system features either Copeland CO₂ hermetic scroll or Bitzer reciprocating compressors and a high-efficiency plate suction-liquid heat exchanger.
- HFC system charge can be further minimized by using water-cooled condensers and hydronic heat-reclaim loops.
- Multiple suction groups on low-temperature system can further improve system efficiency.



Hill PHOENIX

REFRIGERATION SYSTEMS

709 Sigman Road, Conyers, GA 30013

770-285-3100 phone • 770-285-3071 fax

website: www.hillphoenix.com

e-mail: marketing-refrigerationsystems@hillphoenix.com