

# 6NDMLH-NRG

4', 6', 8' & 12' Narrow Multi-Deck Merchandiser with Synerg-E™  
Beverage / Bulk Produce / Bakery / Dairy / Cut Produce / Deli

**GENERAL NOTES:**

- "-" indicates that the feature is not available for this case model and/or the data is not available yet.
- LED lights only.

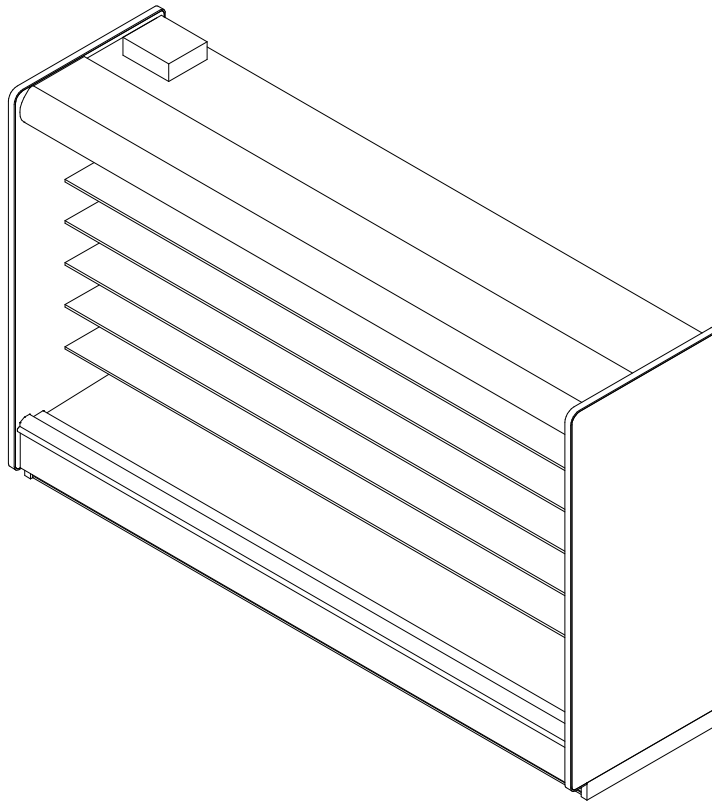

SHIPPING WEIGHT	
Case	Weight
6NDMLH-NRG	---



ALL MEASUREMENTS ARE TAKEN PER ASHRAE-72-2005 SPECIFICATIONS. HILLPHOENIX REFRIGERATED DISPLAY CASES FOR SALE IN THE UNITED STATES MEET OR EXCEED DEPARTMENT OF ENERGY 2017 REQUIREMENTS.

**6NDMLH-NRG**

Rev. Date	Rev. #	Rev. Title
8-3-20	8	SHELF UPDATE
9-23-19	7	OPTIONS UPDATE



# 6NDMLH-NRG

4', 6', 8' & 12' Narrow Multi-Deck Merchandiser with Synerg-E™  
Beverage / Bulk Produce / Bakery / Dairy / Cut Produce / Deli

ELECTRICAL DATA			
Case Length	Fans Per Case	High Efficiency Fans	
		120 Volt	
		Amps	Watts
4'	2	0.38	43.0
6'	3	0.57	65.0
8'	3	0.57	65.0
12'	4	0.76	87.0

LIGHTING DATA					
Case Length	Lights per row	Clearvoyant v4 LED Lighting (Per Light Row)			
		Standard Power (Cornice or Shelf)		High Power (Cornice Only)	
		120 Volts		120 Volts	
		Amps	Watts	Amps	Watts
4'	1	0.05	5.9	0.12	14.9
6'	2	0.08	9.4	0.20	23.8
8'	2	0.10	11.8	0.25	29.9
12'	3	0.15	17.6	0.37	44.8

GUIDELINES AND CONTROL SETTINGS							
Application	Front Sill height	BTUH/ft		Superheat Set Point @ Bulb (°F)	Evaporator (°F)	Discharge Air (°F)	Discharge Air Velocity (FPM)
		Conventional	Parallel				
Bakery/Dairy/Deli/Cut Produce	Standard	1862	1748	6 - 8	28	31	260
Beverage/Bulk Produce	Standard	1860	1819	6 - 8	34	37	260

DEFROST CONTROLS			
Application	Defrosts Per Day	Timed-Off Defrost	
		Fail-Safe (Min)	Termination Temp (F)
Bakery/Dairy/Deli/Cut Produce	6	40	47
Beverage/Bulk Produce	2	30	47

## NOTES:

- "-" indicates that the feature is not available for this case model and/or the data is not available yet.
- Listed BTUH/ft data represent unlighted shelves. For LED lighting, add 9 BTUH/ft to determine Total Case Lighting BTUH Load, then divide by the length of the case to obtain a value in BTUH/ft. BTUH load increases by 132 BTUH/ft when aftermarket merchandising accessories are utilized.
- Listed evaporator temperature represents unlighted shelves. For lighted shelves and/or aftermarket merchandising accessories, reduce the listed evaporator temperature by 2°F.
- Conventional Discharge Air Control – Recommended Settings: Cut-In Temp = Discharge Air + 2°F; Cut-Out Temp = Discharge Air - 2°F.
- Listed discharge air velocity represents the average velocity immediately after defrost.
- Temperature and defrost settings listed below are recommended start-up settings. Final operational settings may need to be adjusted for the store conditions in which the case operates.
- The recommended evaporator temperatures may need to be adjusted based on system setup, store conditions, etc. The minimum recommended evaporator temperature is 4°F below the listed evaporator temperature.



ALL MEASUREMENTS ARE TAKEN PER ASHRAE-72-2005 SPECIFICATIONS. HILLPHOENIX REFRIGERATED DISPLAY CASES FOR SALE IN THE UNITED STATES MEET OR EXCEED DEPARTMENT OF ENERGY 2017 REQUIREMENTS.

## 6NDMLH-NRG

Rev. Date	Rev. #	Rev. Title
8-3-20	8	SHELF UPDATE
9-23-19	7	OPTIONS UPDATE

**Hillphoenix**  
A DOVER COMPANY

# 6NDMLH-NRG

4', 6', 8' & 12' Narrow Multi-Deck Merchandiser with Synerg-E™  
Beverage / Bulk Produce / Bakery / Dairy / Cut Produce / Deli

SECOND NATURE DATA								
Case Model	No. of Coils	Application	Front Sill Height	BTUH/FT		GPM/ft (DR)	Supply Fluid Temp (°F)	Discharge Air Temp (°F)
				Conventional	Parallel			
6NDMLH-NRG	1	Bakery/Deli/Dairy/Cut Produce	Standard	1862	1748	0.46	20	31
6NDMLH-NRG	1	Bulk Produce/Beverage	Standard	1860	1819	0.21	20	37
6NDMLH-NRG	1	Bakery/Deli/Dairy/Cut Produce	Standard	1862	1748	0.83	25	31
6NDMLH-NRG	1	Bulk Produce/Beverage	Standard	1860	1819	0.38	25	37

SECOND NATURE DATA									
Case Model	No. of Coils	Application	Front Sill Height	Supply Fluid Temp (°F)	No. of Defrost	Timed-Off Defrost		Warm Fluid Defrost	
						Fail-Safe (Min)	Termination Temp (°F)	Fail-Safe (Min)	Termination Temp (°F)
6NDMLH-NRG	1	Bakery/Deli/Dairy/Cut Produce	Standard	20	6	60	47	26	49
6NDMLH-NRG	1	Bulk Produce/Beverage	Standard	20	6	60	47	26	49
6NDMLH-NRG	1	Bakery/Deli/Dairy/Cut Produce	Standard	25	6	45	42	26	49
6NDMLH-NRG	1	Bulk Produce/Beverage	Standard	25	6	45	42	26	49

## NOTES:

- All medium temperature data listed is for 35% by wt. PROPYLENE GLYCOL.
- Inhibited Propylene Glycol solution with water, such as Dowfrost or equivalent. (Dowfrost is a trademark of the Dow Chemical Company).
- Flowrates are determined by ASHRAE test conditions and may need to be adjusted based on store conditions.
- \*\* Flowrates are per case



ALL MEASUREMENTS ARE TAKEN PER ASHRAE-72-2005 SPECIFICATIONS. HILLPHOENIX REFRIGERATED DISPLAY CASES FOR SALE IN THE UNITED STATES MEET OR EXCEED DEPARTMENT OF ENERGY 2017 REQUIREMENTS.

## 6NDMLH-NRG

Rev. Date	Rev. #	Rev. Title
8-3-20	8	SHELF UPDATE
9-23-19	7	OPTIONS UPDATE

**Hillphoenix**  
A DOVER COMPANY

# 6NDMLH-NRG

4', 6', 8' & 12' Narrow Multi-Deck Merchandiser with Synerg-E™  
Beverage / Bulk Produce / Bakery / Dairy / Cut Produce / Deli

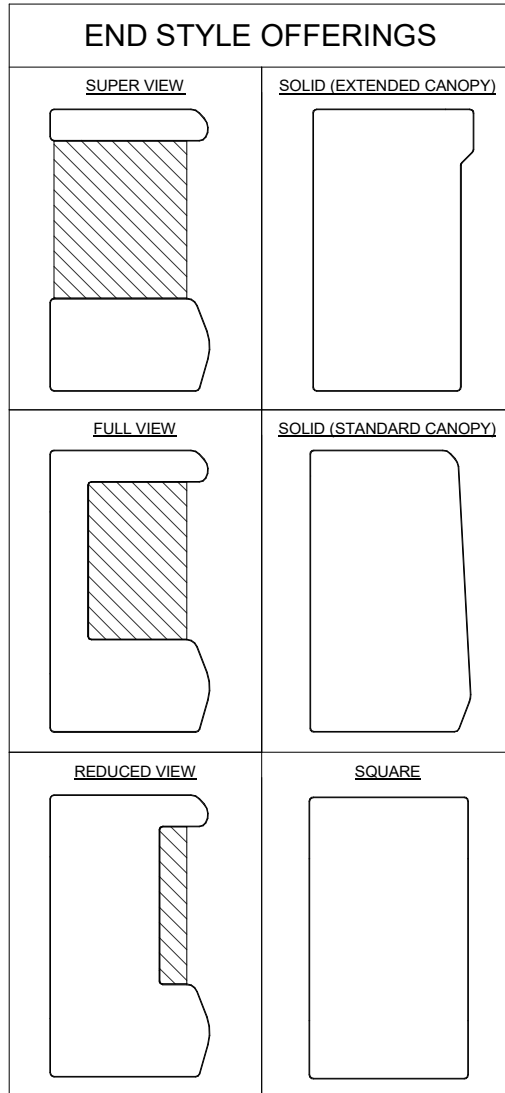

**NOTES:**

- Ends shown are for general use only. Shape, size, and appearance are subject to change based on engineering configuration.
- Hatched regions represent glass inserts.
- Ends add approximately 1" to case height, 1/2" to the back & 1" to the front.
- Ends are available with either polymer end trim or metal end trim.



ALL MEASUREMENTS ARE TAKEN PER ASHRAE-72-2005 SPECIFICATIONS. HILLPHOENIX REFRIGERATED DISPLAY CASES FOR SALE IN THE UNITED STATES MEET OR EXCEED DEPARTMENT OF ENERGY 2017 REQUIREMENTS.







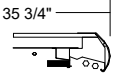
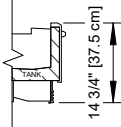

**6NDMLH-NRG**

Rev. Date	Rev. #	Rev. Title
8-3-20	8	SHELF UPDATE
9-23-19	7	OPTIONS UPDATE

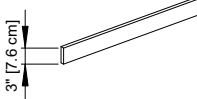
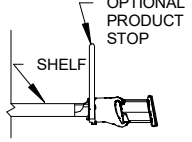
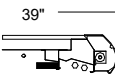
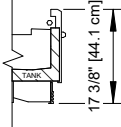

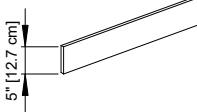
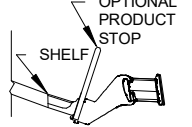
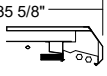
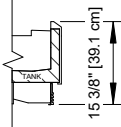
# 6NDMLH-NRG

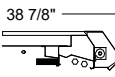
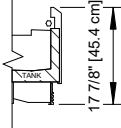
4', 6', 8' & 12' Narrow Multi-Deck Merchandiser with Synerg-E™  
Beverage / Bulk Produce / Bakery / Dairy / Cut Produce / Deli

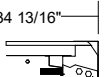
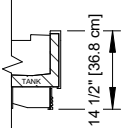
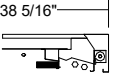
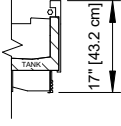
CORNICE OPTIONS	FRONT OPTIONS	SHELF TAG MOLDING OPTIONS	PRODUCT STOP OPTIONS (ONLY APPLICABLE ON SLOTTED TM)	SHELF EDGE ENERGY SAVINGS
<u>CURVED CORNICE</u>  	<u>CLASSIC 2 STANDARD FRONT</u>  	<u>1.25\" STD</u>  	<u>3\" PLEXI PRODUCT STOPS</u>  	<u>ECO BLADE FLAT SHELF</u>  
<u>CURVED CORNICE WITH NIGHT COVER</u>  	<u>CLASSIC 2 17\" FRONT W/ &amp; W/O NOSE LIGHT</u>  	<u>SLOTTED</u>  	<u>5\" PLEXI PRODUCT STOPS</u>  	<u>ECO BLADE ANGLED SHELF</u>  
<u>FACETED CORNICE</u>  	<u>ANGLED FRONT</u>  	<u>ANGLED</u>  	<u>WIRE FENCE PRODUCT STOPS</u>  	
<u>FACETED CORNICE WITH NIGHT COVER</u>  	<u>ANGLED FRONT W/ &amp; W/O NOSE LIGHT</u>  	<u>ANGLED SLOTTED</u>  		
<u>FLAT CORNICE</u>  	<u>FLAT FRONT</u>  			
<u>FLAT CORNICE WITH NIGHT COVER</u>  	<u>17\" FLAT FRONT W/ &amp; W/O NOSE LIGHT</u>  			

**NOTES:**

- Tag molding materials are PVC, aluminum, or painted aluminum.
- See Ecoblade tech sheet for additional information.



ALL MEASUREMENTS ARE TAKEN PER ASHRAE-72-2005 SPECIFICATIONS. HILLPHOENIX REFRIGERATED DISPLAY CASES FOR SALE IN THE UNITED STATES MEET OR EXCEED DEPARTMENT OF ENERGY 2017 REQUIREMENTS.

**6NDMLH-NRG**

Rev. Date	Rev. #	Rev. Title
8-3-20	8	SHELF UPDATE
9-23-19	7	OPTIONS UPDATE



# 6NDMLH-NRG

Narrow Multi-Deck Merchandiser with Synerg-E™  
4', 6', 8' & 12' (Beverage / Dairy / Deli / Produce)

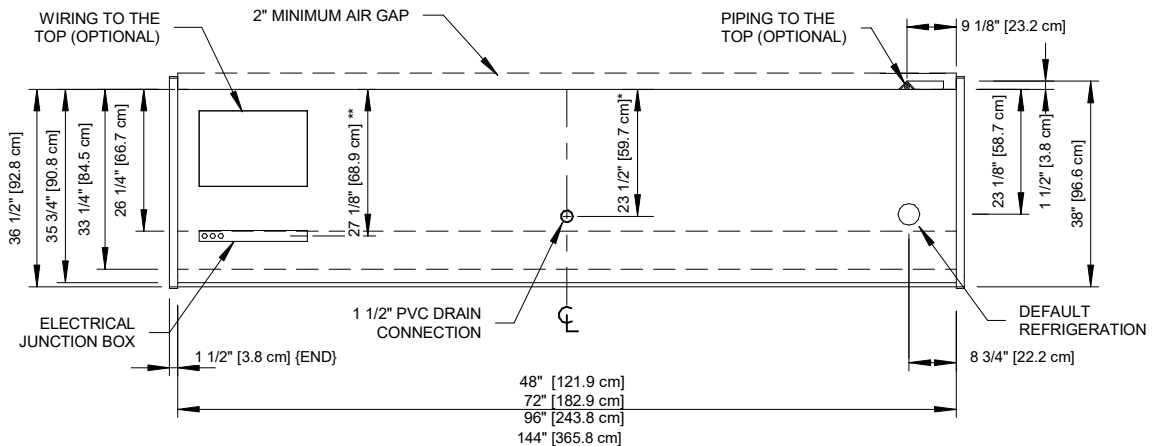
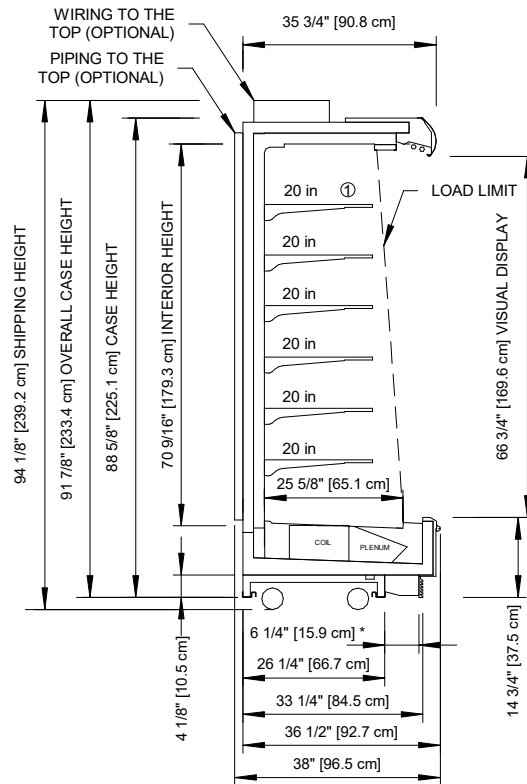

**NOTES:**

- \* : STUB-UP AREA
- \*\* : RECOMMENDED STUB-UP CENTERLINE FOR ELECTRICAL AND HUB DRAINS
- ① : AVAILABLE SHELF SIZES: 10", 12", 14", 16", 18", 20", 22" ; (6) ROWS OF SHELVES MAX

- Ends add approximately 1" to case height.
- Back panels add approximately 1" to the rear of the case.



ALL MEASUREMENTS ARE TAKEN PER ASHRAE-72-2005 SPECIFICATIONS. HILLPHOENIX REFRIGERATED DISPLAY CASES FOR SALE IN THE UNITED STATES MEET OR EXCEED DEPARTMENT OF ENERGY 2017 REQUIREMENTS.

**6NDMLH-NRG**

Rev. Date	Rev. #	Rev. Title
8-3-20	8	SHELF UPDATE
9-23-19	7	OPTIONS UPDATE

