

Hillphoenix

a **DOVER** company

BLF-CR

Self-Service Multi-Deck

Refrigerated cake display with counter-height work station.



Photo may depict options not included on standard models.

Model BLF-CR
Self-Service Multi-Deck

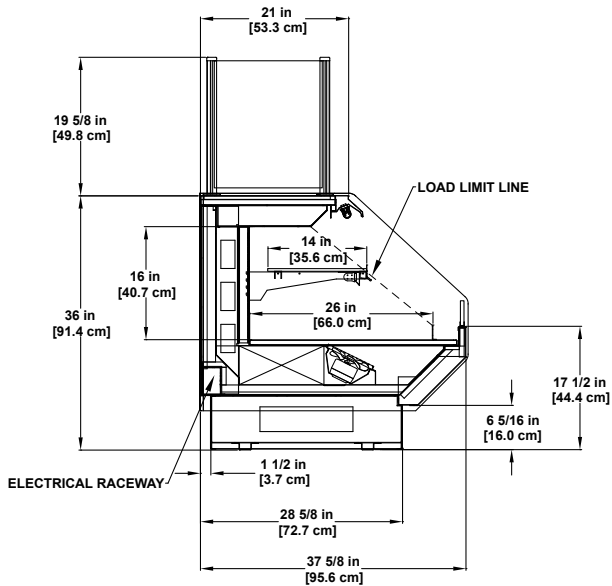

Please consult Hillphoenix Engineering Reference Manual for dimensions, plan views and technical specifications. Specifications subject to change without notice. Designed for optional performance in store environments where temperature and humidity do not exceed 75 degrees and 55% R.H. Certified to UL 471 and ANSI/NSF Standard 7.

Base Model Features

- Sled runner base construction.
- Standard 36"H and 37-5/8"D.
- Standard 6-5/16"H toekick.
- Painted metal exterior.
- Stainless steel exterior trim.
- Stainless steel front, side and rear base trim.
- Stainless steel outside back and case top.
- Single-pane, regular-glare front glass in 19-9/16"H grooved sneezeguard posts.
- Polished dieboard plex.
- Black painted metal interior.
- (1) row 14" fixed flat, adjustable black painted metal shelving with black price tag molding.
- 120-1-60 electrical.
- Clearvoyant® LED top light.
- Clearvoyant LED undershelf lighting.
- Rear electrical raceway.
- Energy efficient fans.
- Remote DX refrigeration package.

Available Options

- Glass or solid laminated interior or mirror polished end panels.
- Exterior standard grade laminate.
- Interior or exterior stainless steel finish.
- Interior white or other custom color finish.
- Painted base and end panel trim.
- Black or white wire, glass, or white painted metal shelving.
- Cart bumper.
- Bread shelf.
- Polytop or solid surface work top, flip up work top.
- Open or closed dry rear storage or refrigerated rear storage w/clear glass sliding doors.
- Self-contained refrigeration package.
- Remote glycol or CO₂ refrigeration packages.



Dover Food Retail
Conyers, GA USA
844.591.5937
hillphoenix.com

©2018 Hillphoenix, Inc.



DOVER company