

Hillphoenix

a **DOVER** company

BLF-SR

Self-Service Multi-Deck

Refrigerated bakery merchandiser.



Photo may depict options not included on standard models.

Model BLF-SR
Self-Service Multi-Deck

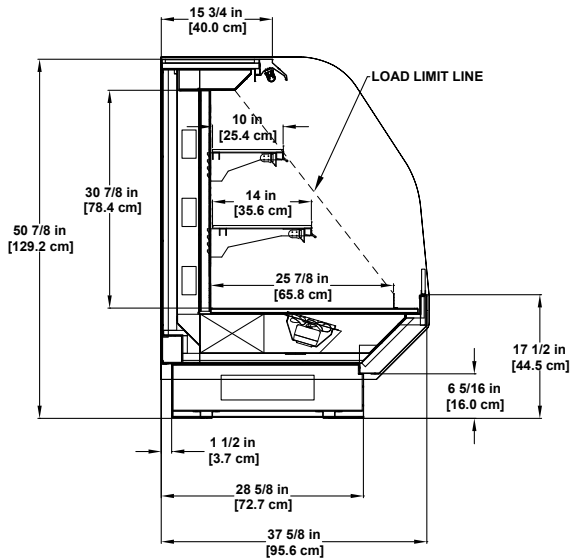

Please consult Hillphoenix Engineering Reference Manual for dimensions, plan views and technical specifications. Specifications subject to change without notice. Designed for optimal performance in store environments where temperature and humidity do not exceed 75 degrees and 55% R.H. Certified to UL 471 and ANSI/NSF Standard 7.

Base Model Features

- Sled runner base construction.
- Standard 50-7/8”H (case top) and 37-5/8”D.
- Standard 6-5/16”H toe-kick.
- Painted metal exterior.
- Stainless steel exterior trim.
- Stainless steel front, side and rear base trim.
- Outside back and case top painted to match exterior.
- Polished dieboard plex.
- Black painted metal interior.
- Interior trim to match interior.
- (1) row each 10” and 14” fixed flat, adjustable black painted metal shelving with black price tag molding.
- Clearvoyant® LED top light.
- Clearvoyant LED undershelf lighting.
- Rear electrical raceway.
- Energy efficient fans.
- Remote DX refrigeration package.

Available Options

- Glass or solid laminated interior or mirror polished end panels.
- Exterior standard grade laminate or SS.
- Interior or exterior stainless steel finish.
- Interior white or other custom color finish.
- Painted base and end panel trim.
- Stainless steel outside back finish.
- Glass, black, chrome or white wire, or white painted metal shelving.
- Swing or sliding rear load doors (swing recommended).
- Stainless steel, solid surface or stone case top.
- Self contained with 7-13/16” toe-kick/ 19” dieboard height (no change to overall height).
- Cart bumper.
- Remote glycol or CO₂ refrigeration package.



Dover Food Retail
Conyers, GA USA
844.591.5937
hillphoenix.com

©2018 Hillphoenix, Inc.



an HILLER company