

Self-Service Single-Deck

Mobile merchandiser for bakery, cheese, deli, meat, produce and beverages.

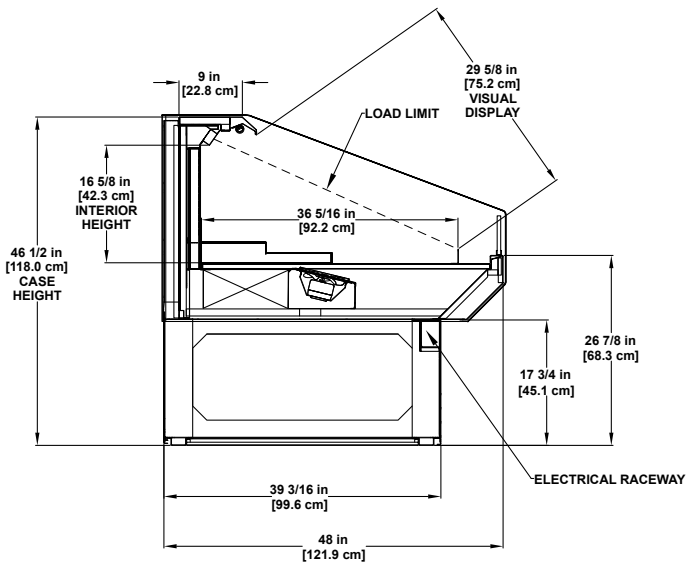

Photo may depict options not included on standard models.



Please consult Hillphoenix Engineering Reference Manual for dimensions, plan views and technical specifications. Specifications subject to change without notice. Designed for optimal performance in store environments where temperature and humidity do not exceed 75° F and 55% R.H. Certified to UL 471 and ANSI/NSF Standard 7.

Base Model Features

- Closed base construction
- Recessed casters with front leveling pads on case-widths 4' or greater (on self contained versions only).
- Flush-mount casters on case-widths less than 4' (on self-contained only).
- No casters with leveling pads (on remote versions).
- Standard 46-1/2"H and 48"D.
- Standard 17-3/4"H base.
- Painted metal exterior, including case top.
- Stainless steel exterior trim.
- Painted metal to match exterior front and side base.
- 2" full height rear chimney extension for airflow management, with moire pattern discharge (on self-contained models).
 - The removable outside back of chimney and top enclosure are painted to match exterior.
- 5-1/2"H x 1/2 "thick polished front dieboard plex.
- Black painted metal interior.
- Interior trim to match interior.
- Fixed, flat bottom deck with angled, telescoping black wire rack.
- Interior trim to match interior.
- Front electrical raceway.
- Solar digital thermometer.
- Energy efficient fans.
- Remote DX refrigeration package.

Available Options

- Available lengths: 2', 4', 6', and 8' (self-contained versions).
- Available lengths: 4', 6', 8',10', and 12' (remote versions).
- (1) row each 10" adjustable-angled painted metal shelf (limits adjustability with additional angled wire shelf option).
- Open back 3"H x 23-5/8"D perforated(front) step riser-base + 2 (each step is 1-1/2"H x 11-13/16"D).
- Painted metal base trim.
- Interior and exterior stainless steel finish.
- Oak slats over metal base.
- Clearvoyant® LED top light.
- White or other painted metal interior finish.
- Clearvoyant LED under shelf lighting.
- Cart bumper.
- Solid interior painted, solid interior mirror polish stainless steel, thermal glass divider or glass ends.
- Addition of upper, dry, (1) row each lighted 18"D adjustable-angled wire shelf with wire product stop (MMRA style upper shelf).
- Self-contained refrigeration package.
 - 6' UL cord and plug.
- Remote glycol or CO₂ refrigeration packages.

Self-Contained			
2'	4'	6'	8'

R-290 Refrigerant
 R-404a/R448a Refrigerant



Second Nature® NATURAL environmentally friendly R-290 hydrocarbon refrigerant has an ozone depletion potential (ODP) of zero (0) and a global warming potential of three (3).



Dover Food Retail
Conyers, GA USA
844.591.5937
hillphoenix.com



©2021 Hillphoenix, Inc.