

Self-Service Single-Deck

Mobile merchandiser for bakery, cheese, deli, meat, produce and beverages.

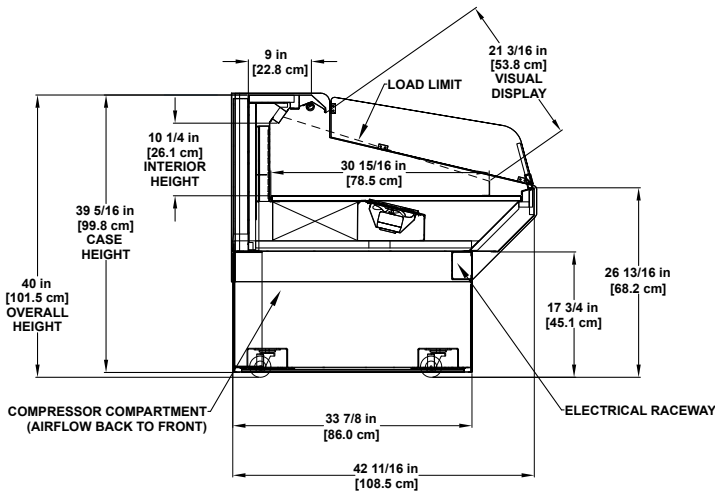



Please consult Hillphoenix Engineering Reference Manual for dimensions, plan views and technical specifications. Specifications subject to change without notice. Designed for optimal performance in store environments where temperature and humidity do not exceed 75° F and 55% R.H. Certified to UL 471 and ANSI/NSF Standard 7.

Base Model Features

- Closed base construction
- 40”H and 42-11/16”D
- Recessed locking casters (On self-contained versions only).
- Standard 17-3/4”H base.
- Painted metal exterior, including case top.
- Stainless steel exterior trim.
- Painted metal to match exterior front and side base.
- Outside back unpainted/galvanneal, including rear base.
- 2” full height rear chimney extension for airflow management with moire pattern discharge.
- 6-1/2”H x 1/2” thick flame polished, angled front die board plex to align with plex-end panel inserts.
- Black painted metal interior.
- Interior trim to match interior.
- Fixed, flat bottom deck with angled, telescoping black wire rack.
- Interior trim to match interior.
- Front electrical raceway.
- Solar digital thermometer.
- Energy-efficient fans.
- Remote DX refrigeration package.

Available Options

- Available lengths: 2’, 4’, 6’, and 8’ (self-contained only).
- Available lengths: 4’, 6’, 8’, 10’ and 12’.
- (1) row each 10” adjustable angled painted metal shelf (limits adjustability with additional angled wire shelf option).
- Alternate finish on wire rack.
- Upper dry shelf: (1) row lighted 18”D adjustable angled wire shelf with wire product stop.
- Clearvoyant® LED top light.
- Painted metal base trim.
- Interior and exterior stainless steel finish.
- Solid wood exterior panels.
- Angled plex on end panels in lieu of straight or radius.
- White or other painted metal interior finish.
- Clearvoyant LED undershelf lighting.
- Cart bumper.
- Solid interior painted, solid interior mirror-polish stainless steel, thermal glass divider or glass ends.
- 6-1/2”H x 1/2” angled glass front die board to align with glass end panel inserts.
- Self-contained refrigeration package.
 - 6’ UL cord and plug.
- Remote glycol or CO₂ refrigeration packages.

Self-Contained			
2'	4'	6'	8'

R-290 Refrigerant

R-404a/R448a Refrigerant



Second Nature® NATURAL environmentally friendly R-290 hydrocarbon refrigerant has an ozone depletion potential (ODP) of zero (0) and a global warming potential of three (3).



Dover Food Retail
Conyers, GA USA
844.591.5937
hillphoenix.com



©2021 Hillphoenix, Inc.