

# Self-Service Single-Deck

Mobile refrigerated merchandiser for bakery, cheese, deli, meat, produce or beverages.

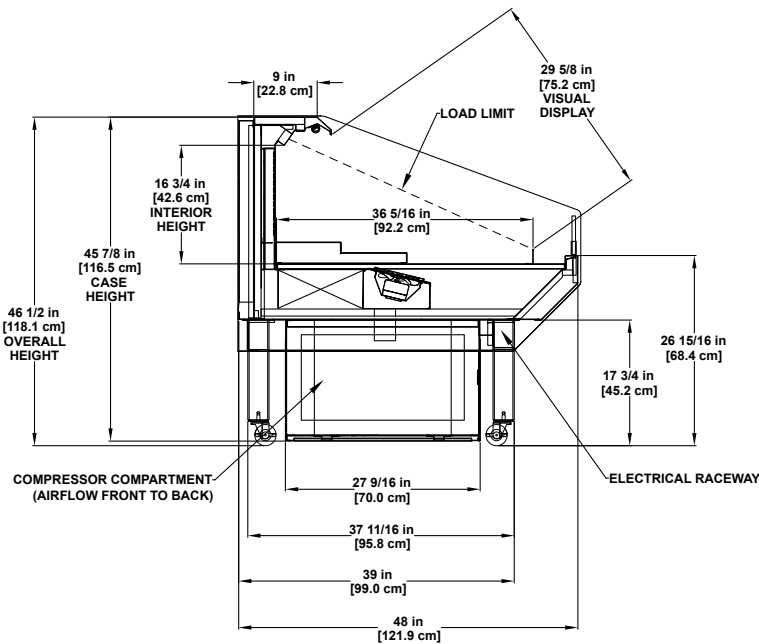

Photo may depict options not included on standard models.



Please consult Hillphoenix Engineering Reference Manual for dimensions, plan views and technical specifications. Specifications subject to change without notice. Designed for optimal performance in store environments where temperature and humidity do not exceed 75° F and 55% R.H. Certified to UL 471 and ANSI/NSF Standard 7.

### Base Model Features

- Open base construction with painted metal leg/non-recessed front locking casters.
- Standard 46-1/2”H and 48”D.
- Standard 17-3/4” base height.
- Painted metal exterior, including case top.
- Stainless steel exterior trim.
- Painted metal to match exterior front, side and rear base.
- Outside back painted metal to match exterior.
- 5-1/2” Polished front dieboard plex.
- Black painted metal interior.
- Interior trim to match interior.
- Fixed, flat bottom deck with angled, telescoping black wire rack.
- Front electrical raceway.
- Solar digital thermometer.
- Energy efficient fans.
- Self-contained refrigeration package.
- -6’ cord and plug.

### Available Options

- Available lengths: 4’, 6’ and 8’ (self-contained only).
- (1) row each 10” adjustable-angled painted metal shelf (limits adjustability with additional angled wire shelf option).
- Open back 3”H x 23-5/8”D perforated (front) step riser-base + 2 (each step is 1-1/2”H x 11-13/16”D).
- Painted metal base trim.
- Interior and exterior stainless steel nish.
- Clearvoyant® LED top light.
- White or other painted metal interior finish.
- Clearvoyant LED under shelf lighting.
- Cart bumper.
- Solid interior painted, solid interior mirror polish stainless steel, thermal glass divider or glass ends.
- Addition of upper, dry, (1) row each lighted 18”D adjustable-angled wire shelf with wire product stop (MMRA style upper shelf).

Self-Contained		
4'	6'	8'

R-290 Refrigerant

R-404a/R448a Refrigerant



Second Nature® NATURAL environmentally friendly R-290 hydrocarbon refrigerant has an ozone depletion potential (ODP) of zero (0) and a global warming potential of three (3).



Dover Food Retail  
Conyers, GA USA  
844.591.5937  
hillphoenix.com



©2021 Hillphoenix, Inc.