

Self-Service Multi-Deck

Refrigerated merchandiser for bakery, beverage, cheese, deli and produce.

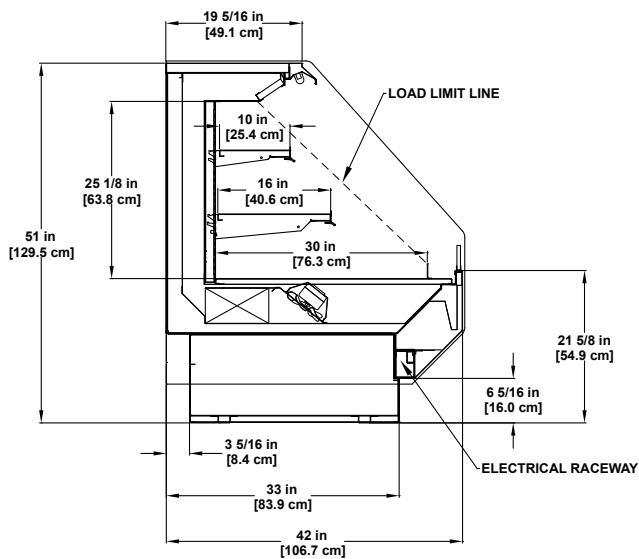



Please consult Hillphoenix Engineering Reference Manual for dimensions, plan views and technical specifications. Specifications subject to change without notice. Designed for optimal performance in store environments where temperature and humidity do not exceed 75° F and 55% R.H. Certified to UL 471 and ANSI/NSF Standard 7.

Base Model Features

- Sled runner base construction.
- Case dimensions: 51”H and 42”D.
- 6-5/16”H stainless steel toe-kick, front and sides.
- Painted metal exterior.
- Outside back and 19-5/16”D case top painted to match exterior.
- Stainless steel exterior trim.
- 5-1/2”H x 1/2” thick polished, straight die board plex.
- Painted Matte black metal interior and trim.
- (1) row Clearvoyant® LED canopy top light.
- (1) row each 10” and 16” non-lighted adjustable flat black painted metal shelving with black price tag molding.
- Painted black metal, flat bottom deck with 2” metal product stop.
- Solar digital thermometer.
- Refrigeration: Remote refrigeration package and energy efficiency fan motors.
- Rear ballast electrical box location.

Available Options

- Case lengths remote: 4’, 6’, 8’, 10’, and 12’.
- Case lengths self-contained: 4’ and 6’.
- Case length self-contained R-290: 4’ and 6’ in only the 54” case height. (Refer to the PF-SC R-290 sales sheet for more information).
- Case heights: 48”, 54” and 72”.
- Alternate toe-kick height: 7-13/16”H with no change to overall height.
- Exterior finishes: Exterior grade laminate or stainless steel.
- Painted metal base trim.
- White or stainless steel case interior.
- (1) row each 10”, 14” and 18” adjustable flat painted metal shelving (54” tall only).
- (1) row each 10”, 12”, 14”, and 18” adjustable flat painted metal shelving (72” tall only).
- Dual top lighting requires 2” case top extension.
- Clearvoyant® LED under shelf lighting.
- Nose light (case grows 2” in depth).
- Solid or full-view end panels with mirror-polished, stainless steel interior.
- Thermal glass divider.
- Cart bumper mounted on front panel of case.
- Cart bumper added to end panels.
- Recessed casters on self-contained refrigeration option.
- Solid surface, stainless steel, or stone case top.
- Rear raceway.
- Refrigeration: Remote glycol or CO2 and self-contained packages.



Dover Food Retail
Conyers, GA USA
844.591.5937
hillphoenix.com

Hillphoenix

©2021 Hillphoenix, Inc.