

ADVANTAGE
SERIES

FROZEN FOOD/ICE CREAM
JUMBO ISLAND MERCHANDISERS

NFJ
NCJ
NTJ



TYLER

NFJ/NCJ/NTJ Frozen Food/Ice Cream Jumbo Island Merchandisers

Tyler's NFJ/NCJ/NTJ Frozen Food/Ice Cream Jumbo Island Merchandisers are factory assembled to serve as multi-purpose merchandisers in your frozen food department. The NFJ is available with dual and medium temperature controls, per case. A split coil NTJ is the perfect solution for twin or dual temperature merchandising, per well.

Standard Features

- U.L. certified to ANSI/NSF 7 Sanitation Standard.
- Energy efficient copper tube, aluminum fin coils ensure product integrity.
- Durable, non-metallic corner protectors are available in colors to match bumpers.
- Environmentally safe CFC-free foam.
- Solid steel base structures add strength and durability.
- Removable fan assembly allows access to coil and drain pan.
- Seamless non-corrosive drain pan for ease of sanitation.
- Color-coded and labeled wiring speeds installation and setup.
- Electric defrost.
- Rigid vinyl bumper, handrail and raceway cover.

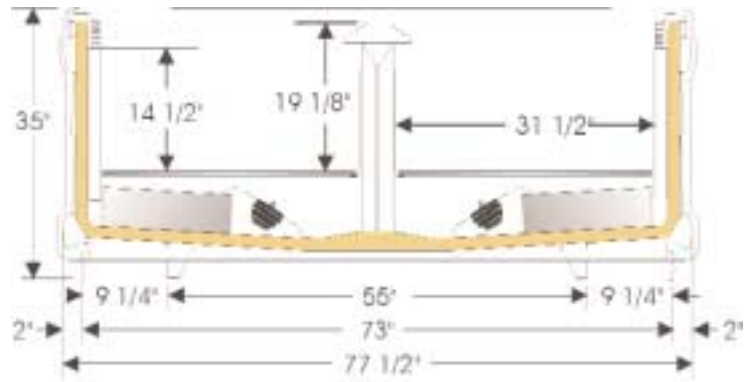

Optional Features

- E.C.M. fan motors reward you with exceptional energy savings.
- White powder coated display screens create your merchandising masterpiece.
- Flat or wrap-around ends are available as an alternative to the seven-foot end cases.
- Non-refrigerated superstructure shelving, with or without lights, adds a variety of merchandising options to your product presentations.
- Split coils per well for NTJ series, allow twin temperature merchandising (frozen food/ice cream) or dual temperature merchandising (frozen food, medium temperature) on opposite sides of the island.
- Dual temperature and medium temperature applications are available per case for the NFJ series..
- Gas defrost.

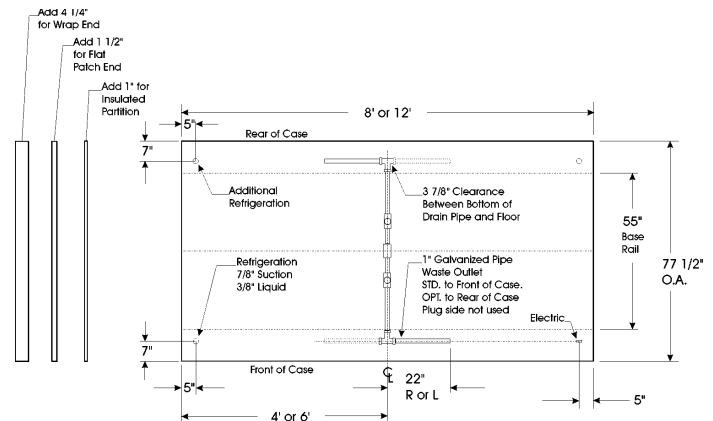

Model	Case Length	Description	Capacity in Cubic Feet
NFJ8	8'	Frozen Food Jumbo Island	50.8
NFJ12	12'	Frozen Food Jumbo Island	76.1
NCJ8	8'	Ice Cream Jumbo Island	50.8
NCJ12	12'	Ice Cream Jumbo Island	76.1
NTJ8	8'	Frozen Food/Ice Cream Jumbo Island	50.8
NTJ12	12'	Frozen Food/Ice Cream Jumbo Island	76.1
NFJE	54.5"	Frozen Food Jumbo Island End	17.5
NCJE	54.5"	Ice Cream Jumbo Island End	17.5

All dimensions are nominal. Specifications are subject to engineering changes without notice.



www.tylerrefrigeration.com
 e-mail sales@tylerrefrigeration.com
 1-800-992-3744

A member of the United Technologies Corporation family
 Stock symbol UTX.



A Division of Carrier Commercial Refrigeration, Inc.
 1329 Lake Street
 Niles, MI 49120

TY-865 4/02
 Printed in U.S.A.