

Installation & Service Manual

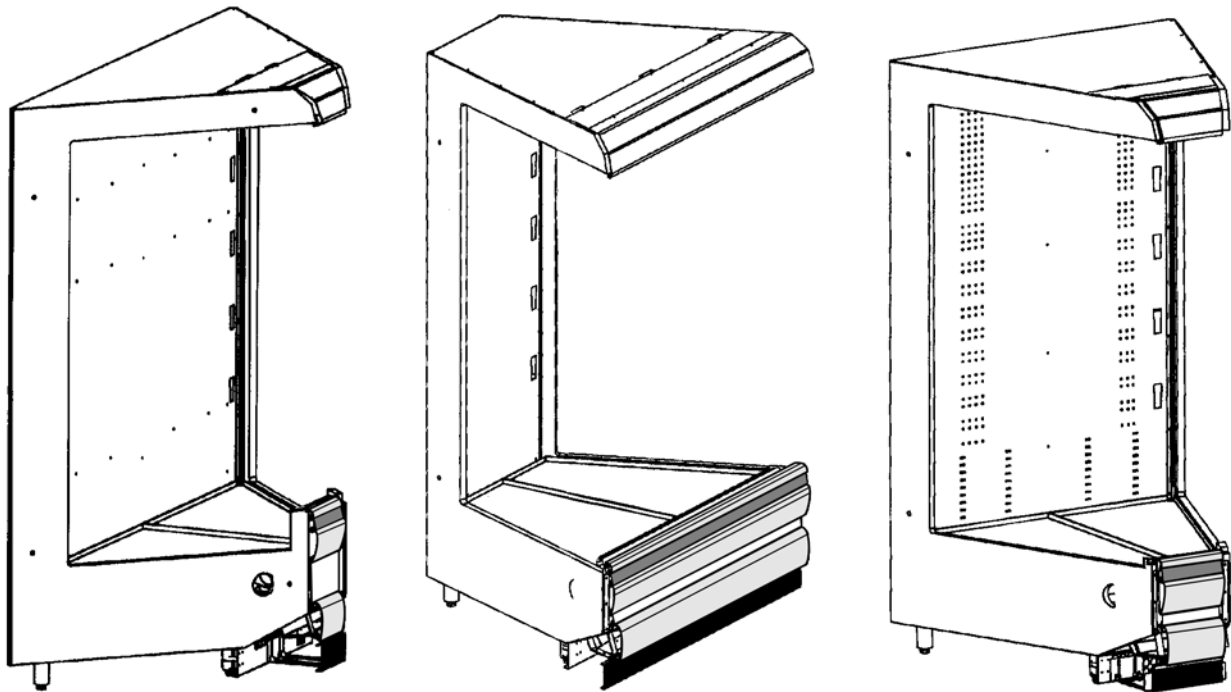

DAIRY/DELI CORNER (WEDGE) CASES

DAIRY/DELI SELF-SERVE INSIDE & OUTSIDE CORNER MERCHANDISERS
Medium Temperature & High Performance Refrigerated Corner Display Cases

**This manual has been designed to be used in conjunction with the
 General (UL/NSF) Installation & Service Manual.**

Save the Instructions in Both Manuals for Future Reference!!

This merchandiser conforms to the American National Standard Institute & NSF International Health and Sanitation standard ANSI/NSF 7 - 2003.

PRINTED IN U.S.A.	Specifications subject to change without notice.	REPLACES EDITION	1/06	ISSUE DATE	4/07	PART NO.	9037173	REV.	B
-------------------	--	------------------	------	------------	------	----------	---------	------	---

CONTENTS

	<u>Page</u>
Specifications	
N6D(L/M/H) Multi-Shelf Inside & Outside Corner Merchandisers . . .	4
N6DHP(L/M/H) Multi-Shelf, High Performance Inside & Outside Corner Merchandisers	7
Pre-Installation Responsibilities (See General-UL/NSF I&S Manual)	
Installation Procedures	
Carpentry Procedures	10
Case Line-Up and Pull-Up Locations	10
Trim & NSF Thermometer Installation	11
Electrical Procedures	11
Electrical Considerations	11
Case Fan Circuit	11
Fluorescent Lamp Circuit	11
Plumbing Procedures (See General-UL/NSF I&S Manual)	
Refrigeration Procedures (See General-UL/NSF I&S Manual)	
Defrost Information	11
Defrost Control Chart	11
Wiring Diagrams	11
N6D(HP) IS & OS Dom. & Exp. (50 Hz) Corner Case Circuits	12
Cleaning and Sanitation	
Component Removal and Installation Instructions for Cleaning	13
Shelves and Shelf Brackets	13
Bottom Trays	13
Front Air Ducts	13
Rear Duct Panels (w/o Shelf Light Sockets)	13
(with Shelf Light Sockets)	13
Discharge Air Honeycomb	13
Top Duct	13
Front Cladding	14
Cleaning Instructions (See General-UL/NSF I&S Manual)	
General Information	
NSF Product Thermometer Installation	14
Service Instructions	
Preventive Maintenance (See General-UL/NSF I&S Manual)	
Fan Blade and Motor Replacement (See Gen.-UL/NSF I&S Manual)	
Color Band & Bumper Replacement (See Gen.-UL/NSF I&S Man.)	
Connecting the Refrigeration Piping and Components	14
Compact Lamp Replacement	15
Discharge Grid Replacement	15
Parts Information	
Operational Parts Lists	16
Cladding and Optional Trim Parts Lists	17
TYLER Warranty (See General-UL/NSF I&S Manual)	

The following Medium Temperature and High Performance, Multi-Shelf, Refrigerated Dairy/Deli Corner Merchandiser models are covered in this manual:

MODELS	DESCRIPTION
N6DL30OS	30° OUTSIDE MULTI-SHELF DAIRY/DELI CORNER MERCHANDISER WITH 18" FRONT
N6DL45IS	45° INSIDE MULTI-SHELF DAIRY/DELI CORNER MERCHANDISER WITH 18" FRONT
N6DL45OS	45° OUTSIDE MULTI-SHELF DAIRY/DELI CORNER MERCHANDISER WITH 18" FRONT
N6DL90IS	90° INSIDE MULTI-SHELF DAIRY/DELI CORNER MERCHANDISER WITH 18" FRONT
N6DM45OS	45° OUTSIDE MULTI-SHELF DAIRY/DELI CORNER MERCHANDISER WITH 22" FRONT
N6DM90IS	90° INSIDE MULTI-SHELF DAIRY/DELI CORNER MERCHANDISER WITH 22" FRONT
N6DM90OS	90° OUTSIDE MULTI-SHELF DAIRY/DELI CORNER MERCHANDISER WITH 22" FRONT
N6DH45IS	45° INSIDE MULTI-SHELF DAIRY/DELI CORNER MERCHANDISER WITH 26" FRONT
N6DH45OS	45° OUTSIDE MULTI-SHELF DAIRY/DELI CORNER MERCHANDISER WITH 26" FRONT
N6DH90IS	90° INSIDE MULTI-SHELF DAIRY/DELI CORNER MERCHANDISER WITH 26" FRONT
N6DHPL30IS	30° INSIDE MULTI-SHELF HIGH PERF. CORNER MERCHANDISER WITH 18" FRONT
N6DHPL45IS	45° INSIDE MULTI-SHELF HIGH PERF. CORNER MERCHANDISER WITH 18" FRONT
N6DHPL45OS	45° OUTSIDE MULTI-SHELF HIGH PERF. CORNER MERCHANDISER WITH 18" FRONT
N6DHPL90IS	90° INSIDE MULTI-SHELF HIGH PERF. CORNER MERCHANDISER WITH 18" FRONT
N6DHPM45IS	45° INSIDE MULTI-SHELF HIGH PERF. CORNER MERCHANDISER WITH 22" FRONT
N6DHPM45OS	45° OUTSIDE MULTI-SHELF HIGH PERF. CORNER MERCHANDISER WITH 22" FRONT
N6DHPM90IS	90° INSIDE MULTI-SHELF HIGH PERF. CORNER MERCHANDISER WITH 22" FRONT
N6DHPH45IS	45° INSIDE MULTI-SHELF HIGH PERF. CORNER MERCHANDISER WITH 26" FRONT
N6DHPH45OS	45° OUTSIDE MULTI-SHELF HIGH PERF. CORNER MERCHANDISER WITH 26" FRONT

DAIRY/DELI-MED TEMP CORNER CASES



SPECIFICATIONS

N6D(L/M/H) Inside & Outside Multi-Shelf Dairy/Deli Corner Merchandisers

Refrigeration Data:

MODEL	CASE LENGTH	CASE USAGE	CAPACITY (BTUH / CASE)		EVAPORATOR (°F)	UNIT SIZING (°F)	DISCHARGE AIR		AVG. REF. CHARGE (LBS/CASE)
			PARALLEL	CONVENTIONAL			TEMPERATURE (°F)	VELOCITY (FPM)	
N6DL30OS	39-5/8"	MED TEMP	5,133	5,500	+21	+19	+34	210	N/A
N6DL45IS	43-7/8"	MED TEMP	4,353	4,664	+21	+19	+32	400	N/A
N6DL45OS	51-1/16"	MED TEMP	5,257	5,633	+21	+19	+34	210	N/A
N6DL90IS	70-7/8"	MED TEMP	4,353	6,664	+21	+19	+32	396	N/A
N6DM45OS	51-1/16"	MED TEMP	5,441	5,830	+21	+19	+34	210	N/A
N6DM90IS	70-7/8"	MED TEMP	4,199	4,499	+21	+19	+32	396	N/A
N6DM90OSNL	78-7/8"	MED TEMP	7,909	8,474	+21	+19	+34	209	N/A
N6DH45IS	43-7/8"	MED TEMP	4,658	8,771	+21	+19	+32	400	N/A
N6DH45OS	51-1/16"	MED TEMP	5,625	6,027	+21	+19	+32	210	N/A
N6DH90IS	70-7/8"	MED TEMP	4,049	4,338	+21	+19	+32	396	N/A

* Capacity data listed for cases with 1 row of T-8 canopy lights, optional T-8 shelf lighting. For sizing all refrigeration equipment other than TYLER, use conventional BTUH values.

** Evaporator temperature is based on the saturated pressure leaving the case.

*** Air velocity measured 1 hour after defrost at the top discharge air duct using an ALNOR JR. velometer with a scoop.

FOR SPECIFIC COMPRESSOR SIZING INFORMATION, REFER TO TYLER APPLICATIONS FOR RACK SYSTEM COMPRESSORS AND/OR THE COMPRESSOR MANUFACTURERS FOR SINGLE COMPRESSORS. FOR LINE SIZING INFORMATION, REFER TO THE MISCELLANEOUS SECTION "BUFF" IN THE TYLER SPECIFICATION GUIDE.

Electrical Data:

Fans and Heaters (120 Volt)

MODEL	CASE LENGTH	FANS / CASE	TOTAL STANDARD FANS		TOTAL ECM FANS		TOTAL ANTI-SWEATS	
			AMPS	WATTS	AMPS	WATTS	AMPS	WATTS
N6DL30OS	39-5/8"	1	0.80	71.0	N/A	N/A	N/A	N/A
N6D45IS	43-7/8"	1	0.53	48.0	N/A	N/A	N/A	N/A
N6D45OS	51-1/16"	1	0.53	48.0	N/A	N/A	N/A	N/A
N6D90IS	70-7/8"	1	1.00	82.6	N/A	N/A	N/A	N/A
N6D90OS	78-7/8"	2	1.60	142.0	N/A	N/A	N/A	N/A

T-8 Lighting with Electronic Ballasts (120 Volt)

MODEL	CASE LENGTH	CANOPY LIGHTS* ONE ROW		SHELF LIGHTS - PER ROW										MAXIMUM LIGHTING (6 ROWS)	
		AMPS	WATTS	AMPS					WATTS					AMPS	WATTS
				1	2	3	4	5	1	2	3	4	5		
N6D30OS	39-5/8"	0.66	79.0	0.34	0.66	0.94	1.13	1.41	40.0	80.0	120.0	160.0	200.0	2.07	279.0
N6D45IS	43-7/8"	0.18	20.0	0.29	0.40	0.62	0.74	0.98	24.0	48.0	72.0	96.0	120.0	1.16	140.0
N6D45OS	51-1/16"	0.66	79.0	0.34	0.66	0.94	1.13	1.41	40.0	80.0	120.0	160.0	200.0	2.07	279.0
N6D90IS	70-7/8"	0.18	20.0	0.34	0.66	0.94	1.13	1.41	40.0	80.0	120.0	160.0	200.0	1.59	220.0
N6D90OS	78-7/8"	0.66	79.0	0.34	0.66	0.94	1.13	1.41	40.0	80.0	120.0	160.0	200.0	2.07	279.0

* Standard lighting for this case is 1 row of canopy lights.

Defrost Data:

DEFROST TYPE*	DEFROSTS PER DAY	DURATION TIME (MIN)	TERM.	USAGE	EPR SETTINGS **		DEFROST WATER (LB / DAY)				
					R22 (PSIG)	R404A (PSIG)	300S	45IS	45OS	90IS	90OS
TIME OFF - ALL MODELS	4	24	- - -	MED TEMP	44	57	28.5	24.8	35.6	24.8	35.6
ELECTRIC - ALL MODELS	4	24	41°F	MED TEMP	44	57					

* If an Electronic Sensor is used for termination, it should be set at 70°F termination temperature. The sensor must be located in the same location as the defrost termination klixon for that defrost type.

** Set EPR to give this pressure at the case

DEFROST CIRCUITS: OFF CYCLE defrost is standard (use TC defrost module) - OPTIONAL ELECTRIC defrost uses a single or 3 phase circuit.

CASE CIRCUITS: This case requires a 120V circuit for fans and lights.

ULSANITATION approved in accordance with ANSI/NSF - 7.

CASE BTUH REQUIREMENTS are calculated to produce approximately the indicated entering-air temperature with absolute maximum operating ambient limits of 75°F & 55RH.

The information contained herein is based on technical analysis and/or tests performed in a controlled lab environment that are consistent with industry practices, and is intended as a reference for system sizing and configuration purposes only and for use by persons having technical skill at their own discretion and risk. Conditions of use are outside of Tyler's control and we do not assume and hereby disclaim any liability for results obtained or damages incurred through application of or reliance on the data presented, including but not limited to specific energy consumption with any particular model or installed application. SPECIFICATIONS ARE SUBJECT TO CHANGE WITHOUT NOTICE.

DAIRY WEDGE CROSS SECTIONS

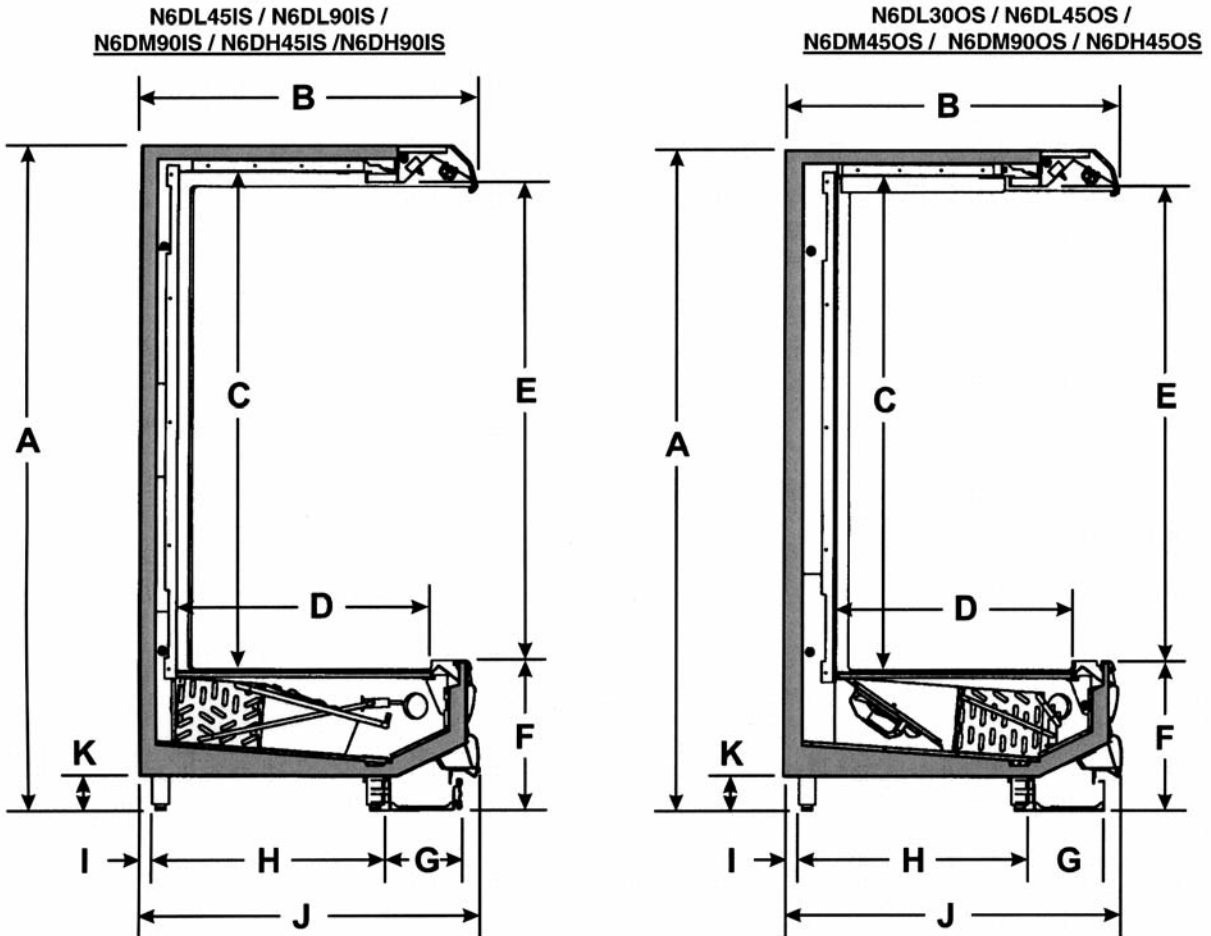

DIMENSIONAL SPECIFICATION	N6DL45IS	N6DL30OS	N6DL45OS	N6DL90IS	N6DM45OS	N6DM90IS	N6DM90OS	N6DH45IS	N6DH45OS	N6DH90IS
A	79"	79"	79"	79"	79"	79"	79"	79"	79"	79"
B	39-3/4"	41"	39-3/4"	31-1/4"	39-3/4"	31-1/4"	30-5/8"	39-3/4"	39-3/4"	31-1/4"
C	59-1/4"	59-1/4"	59-1/4"	59-1/4"	59-1/4"	59-1/4"	59-1/4"	59-1/4"	59-1/4"	59-1/4"
D	30-5/8"	30-1/2"	28-5/8"	22-7/8"	28-5/8"	22-7/8"	20-9/16"	30-5/8"	28-5/8"	22-7/8"
E	56-3/4"	56-3/4"	56-3/4"	56-3/4"	52-7/8"	52-7/8"	52-7/8"	49-1/8"	49-1/8"	49-1/8"
F	18"	18"	18"	18"	21-3/4"	21-3/4"	21-3/4"	25-1/2"	25-1/2"	25-1/2"
G	9-1/8"	9-1/8"	9-1/8"	9-1/8"	9-1/8"	9-1/8"	9-1/8"	9-1/8"	9-1/8"	9-1/8"
H	27-1/2"	27-1/2"	27-1/2"	20-3/4"	27-1/2"	20-3/4"	20-3/4"	27-1/2"	27-1/2"	20-3/4"
I	1-1/2"	1-1/2"	1-1/2"	1-1/2"	1-1/2"	1-1/2"	1-1/2"	1-1/2"	1-1/2"	1-1/2"
J	40-1/4"	41-9/16"	40-1/4"	31-7/16"	40-1/4"	31-7/16"	31-7/16"	40-1/4"	40-1/4"	31-7/16"
K	4"	4"	4"	4"	4"	4"	4"	4"	4"	4"

DAIRY/DELI-MED TEMP CORNER CASES



DAIRY WEDGE FLOOR PLANS

N6DL300S

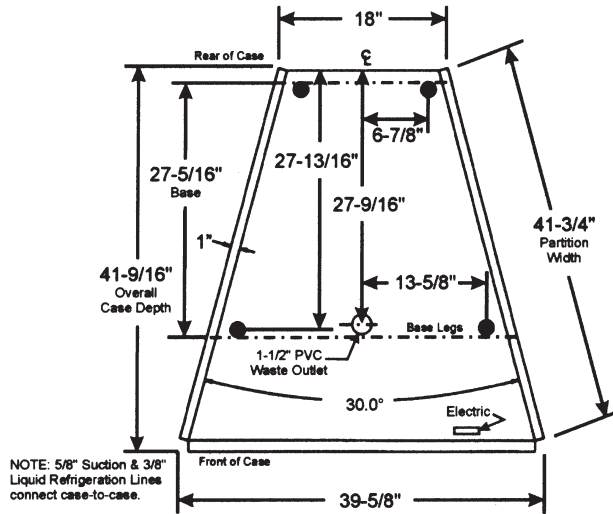

N6DL45IS / N6DH45IS

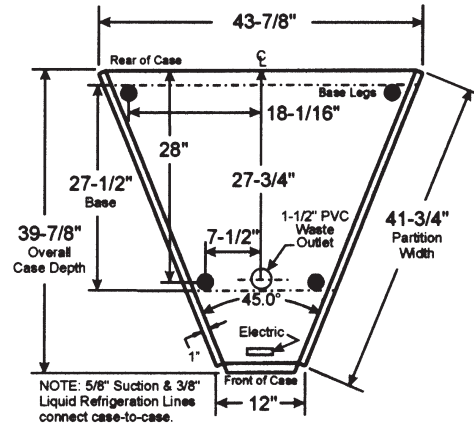

N6DL45OS / N6DM45OS / N6DH45OS

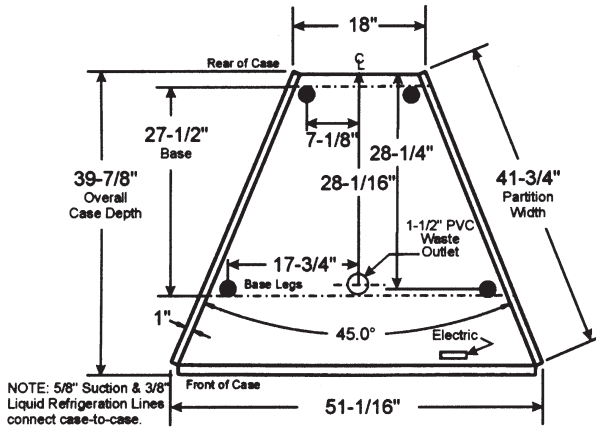

N6DL90IS / N6DM90IS / N6DH90IS

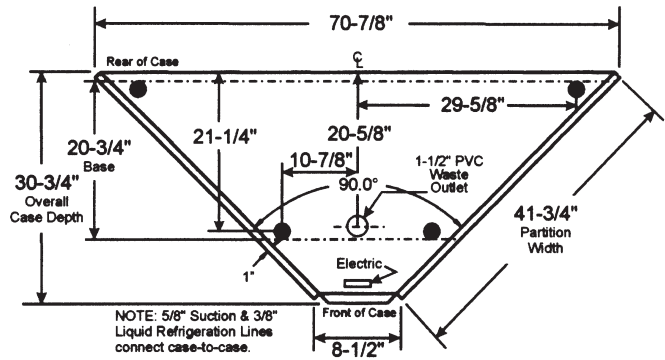

N6DM90OSNL

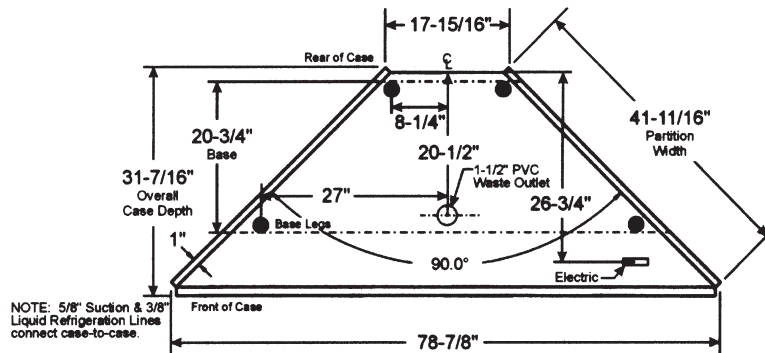

DIARY/DELI-MED TEMP CORNER CASES

Installation & Service Manual

N6DHP(L/M/H) Inside & Outside Multi-Shelf High Performance Corner Merchandisers

Refrigeration Data:

MODEL	CASE LENGTH	CASE USAGE	CAPACITY (BTUH / CASE)		EVAPORATOR (°F)	UNIT SIZING (°F)	DISCHARGE AIR		AVG. REF. CHARGE (LBS/CASE)
			PARALLEL	CONVENTIONAL			TEMPERATURE (°F)	VELOCITY (FPM)	
N6DHPL30IS	33-5/8"	MED TEMP	3,800*	4,108*	+28**	+26	+33	233***	1.63
N6DHPL45IS	43-7/8"	MED TEMP	3,935*	4,254*	+28**	+26	+33	233***	1.63
N6DHPL45OS	51-1/16"	MED TEMP	6,487*	6,951*	+28**	+26	+36	205***	1.31
N6DHPL90IS	70-7/8"	MED TEMP	2,105*	2,255*	+28**	+26	+33	233***	1.63
N6DHPM45IS	43-7/8"	MED TEMP	3,777*	4,083*	+28**	+26	+33	233***	1.63
N6DHPM45OS	51-1/16"	MED TEMP	6,226*	6,672*	+28**	+26	+36	205***	1.31
N6DHPM90IS	70-7/8"	MED TEMP	3,890*	4,206*	+28**	+26	+33	233***	1.63
N6DHPH45IS	43-7/8"	MED TEMP	3,622*	3,915*	+28**	+26	+33	233***	1.63
N6DHPH45OS	51-1/16"	MED TEMP	5,971*	6,398*	+28**	+26	+36	205***	1.31
N6DHPH90IS	70-7/8"	MED TEMP	3,731*	4,032*	+28**	+26	+33	233***	1.63

* Capacity data listed for cases with 1 row of canopy lights and 4 rows of unlighted shelves. For sizing all refrigeration equipment other than TYLER, use conventional BTUH values.

** Evaporator temperature is based on the saturated pressure leaving the case.

*** Air velocity measured 1 hour after defrost at the top discharge air duct using an ALNOR JR. velometer with a scoop.

FOR SPECIFIC COMPRESSOR SIZING INFORMATION, REFER TO TYLER APPLICATIONS FOR RACK SYSTEM COMPRESSORS AND/OR THE COMPRESSOR MANUFACTURERS FOR SINGLE COMPRESSORS. FOR LINE SIZING INFORMATION, REFER TO THE MISCELLANEOUS SECTION "BUFF" IN THE TYLER SPECIFICATION GUIDE.

Electrical Data:

Fans and Heaters (120 Volt)

MODEL	CASE LENGTH	FANS / CASE	TOTAL STANDARD FANS		TOTAL ECM FANS		TOTAL ANTI-SWEATS	
			AMPS	WATTS	AMPS	WATTS	AMPS	WATTS
N6DHP30IS	33-5/8"	1	0.53	48.0	N/A	N/A	N/A	N/A
N6DHP45IS	43-7/8"	1	1.00	82.6	N/A	N/A	N/A	N/A
N6DHP45OS	51-1/16"	1	1.00	82.6	N/A	N/A	N/A	N/A
N6DHP90IS	70-7/8"	1	1.00	82.6	N/A	N/A	N/A	N/A

T-8 Lighting with Electronic Ballasts (120 Volt)

MODEL	CASE LENGTH	CANOPY LIGHTS* ONE ROW		SHELF LIGHTS – PER ROW								MAXIMUM LIGHTING (5 ROWS)	
		AMPS	WATTS	AMPS				WATTS				AMPS	WATTS
				1	2	3	4	1	2	3	4		
N6DHP30IS	33-5/8"	0.30	36.0	0.25	0.50	0.75	1.00	30.0	60.0	90.0	120.0	1.30	156.0
N6DHP45IS	43-7/8"	0.30	36.0	0.25	0.50	0.75	1.00	30.0	60.0	90.0	120.0	1.30	156.0
N6DHP45OS	51-1/16"	0.34	41.0	0.25	0.50	0.75	1.00	30.0	60.0	90.0	120.0	1.34	161.0
N6DHP90IS	70-7/8"	0.30	36.0	0.25	0.50	0.75	1.00	30.0	60.0	90.0	120.0	1.30	156.0

* Standard lighting for this case is 1 row of canopy lights.

Defrost Data:

DEFROST TYPE*	DEFROSTS PER DAY	DURATION TIME (MIN)	ELEK. THERMOSTAT / AIR SENSOR SETTINGS			EPR SETTINGS ***		CONVENTIONAL COMPRESSOR SETTINGS ****				DEFROST WATER (LB / DAY)
			USAGE	CUT IN	CUT OUT	R22 (PSIG)	R404A (PSIG)	R22 (PSIG) CUT-IN CUT-OUT		R404A (PSIG) CUT-IN CUT-OUT		
TIME OFF – N6DHP30IS	6	18**	MED TEMP	34°F	32°F	52	66	50	36	64	47	17.0
TIME OFF - N6DHP45IS	6	18**	MED TEMP	34°F	32°F	52	66	50	36	64	47	22.2
TIME OFF - N6DHP45OS	6	16**	MED TEMP	34°F	32°F	52	66	50	36	64	47	25.8
TIME OFF - N6DHP90IS	6	18**	MED TEMP	34°F	32°F	52	66	50	36	64	47	35.8

* All high performance cases use OFF CYCLE defrost.

** NOTE: 16 or 18 minutes is for EPR with suction stop for defrost isolation. Defrost times increases by four minutes when defrost isolation is by pump down.

*** If EPR is utilized, use the settings shown in the chart. ADD 0.5# to EPR setting for each 1000 foot rise in elevation.

**** Required setup for a conventional unit uses an electronic thermostat to assure accurate temperature control.

CASE CIRCUITS: This case requires a 120V circuit for fans and lights.

UL SANITATION approved in accordance with ANSI-NSF – 7.

CASE BTUH REQUIREMENTS are calculated to produce approximately the indicated entering-air temperature with absolute maximum operating ambient limits of 75°F & 55RH.

The information contained herein is based on technical analysis and/or tests performed in a controlled lab environment that are consistent with industry practices, and is intended as a reference for system sizing and configuration purposes only and for use by persons having technical skill at their own discretion and risk. Conditions of use are outside of Tyler's control and we do not assume and hereby disclaim any liability for results obtained or damages incurred through application of or reliance on the data presented, including but not limited to specific energy consumption with any particular model or installed application. SPECIFICATIONS ARE SUBJECT TO CHANGE WITHOUT NOTICE.

DAIRY WEDGE CROSS SECTIONS

N6DHPL30IS / N6DHPL45IS / N6DHPL90IS /
N6DHPM45IS / N6DHPM90IS / N6DHPH45IS / N6DHPH90IS

N6DHPL45OS / N6DHPM45OS / N6DHPH45OS

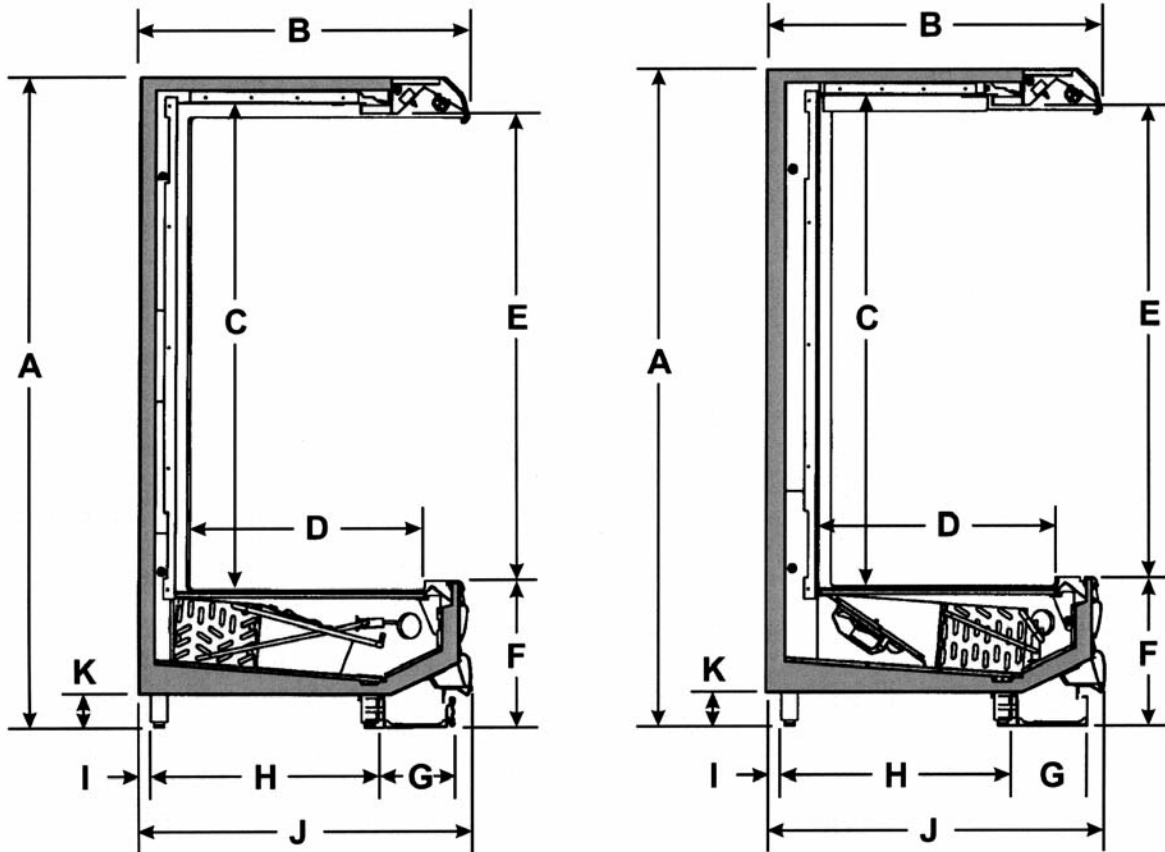

DIMENSIONAL SPECIFICATION	N6DHPL 30IS	N6DHPL 45IS	N6DHPL 45OS	N6DHPL 90IS	N6DHPM 45IS	N6DHPM 45OS	N6DHPM 90IS	N6DHPH 45IS	N6DHPH 45OS	N6DHPH 90IS
A	79"	79"	79"	79"	79"	79"	79"	79"	79"	79"
B	41-1/2"	39-3/4"	39-3/4"	31"	39-3/4"	39-3/4"	31"	39-3/4"	39-3/4"	31"
C	59-1/4"	59-1/4"	59-1/4"	59-1/4"	59-1/4"	59-1/4"	59-1/4"	59-1/4"	59-1/4"	59-1/4"
D	32-1/8"	30-5/8"	28-5/8"	20-7/8"	30-5/8"	28-5/8"	22-3/4"	30-5/8"	28-5/8"	20-7/8"
E	56-3/4"	56-3/4"	56-3/4"	55-1/2"	52-7/8"	52-7/8"	52-7/8"	49-1/8"	49-1/8"	49-1/8"
F	18"	18"	18"	18"	21-3/4"	21-3/4"	21-3/4"	25-1/2"	25-1/2"	25-1/2"
G	9-1/8"	9-1/8"	9-1/8"	9"	9-1/8"	9-1/8"	9"	9-1/8"	9-1/8"	9"
H	28-7/8"	27-1/2"	27-1/2"	20-3/4"	27-1/2"	27-1/2"	20-3/4"	27-1/2"	27-1/2"	20-3/4"
I	1-1/2"	1-1/2"	1-1/2"	1-1/2"	1-1/2"	1-1/2"	1-1/2"	1-1/2"	1-1/2"	1-1/2"
J	42"	40-1/4"	40-1/4"	31-1/4"	40-1/4"	40-1/4"	31-1/4"	40-1/4"	40-1/4"	31-1/4"
K	4"	4"	4"	4"	4"	4"	4"	4"	4"	4"

DAIRY WEDGE FLOOR PLANS

N6DHPL30IS

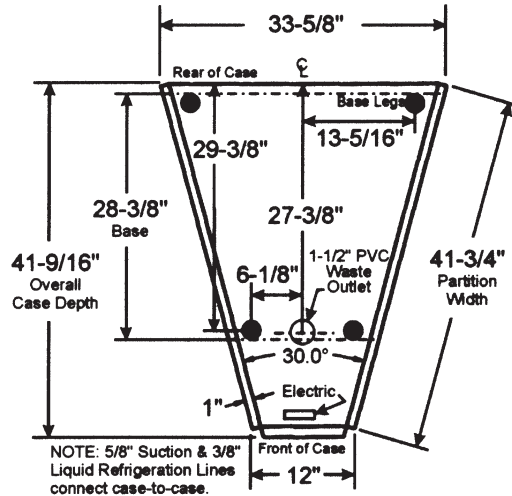

N6DHPL45IS / N6DHPM45IS / N6DHPH45IS

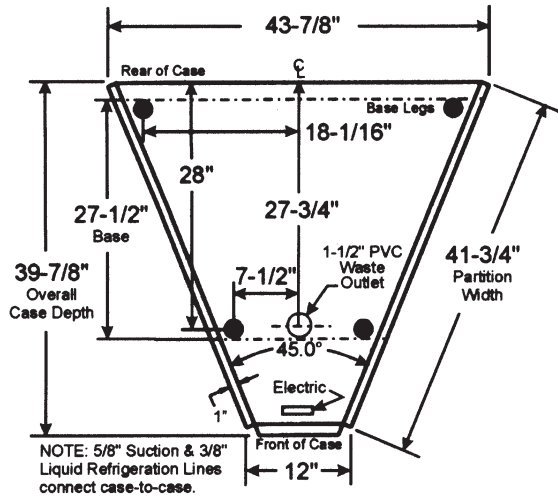

N6DHPL45OS / N6DHPM45OS / N6DHPH45OS

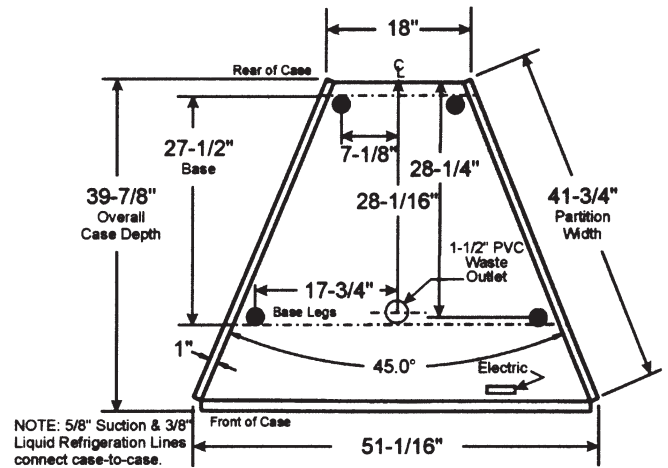

N6DHPL90IS / N6DHPM90IS / N6DHPH90IS

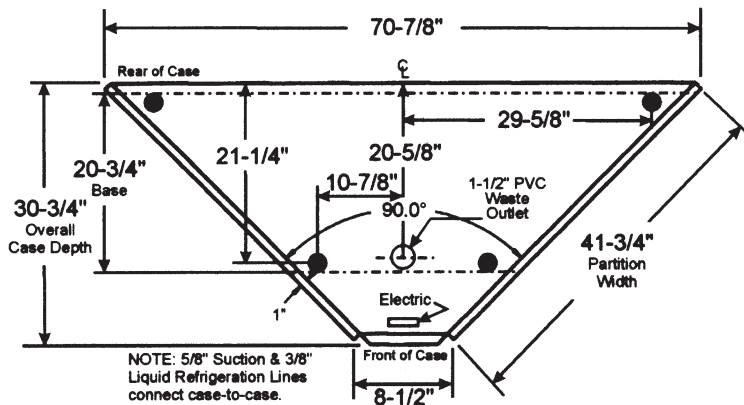

INSTALLATION PROCEDURES

WARNING

Corner cases are not intended as stand alone commercial refrigerated merchandisers. They must be bolted to the adjoining case(s) to provide stability. Failure to do so could result in product damage and/or possible personal injury.

Carpentry Procedures

Case Line-up and Pull-Up Locations

Before starting the case line-up, review the store layout floorplans and survey the areas where case line-ups are going to be installed.

WARNING

Corner cases can be very heavy and possibly top heavy before they are secured in a line-up. Always use a lifting device to remove case from skid and two or more people to move and position case. Improper handling of cases could result in product damage and/or personal injury.

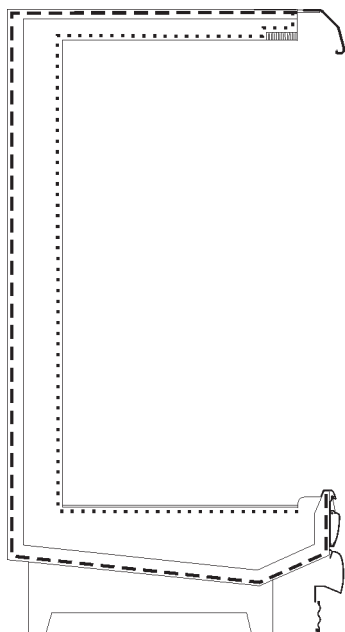

1. Apply two heavy beads of caulking compound from the Filler Kit to the ends of the adjoining cases at dotted (. . .) and dashed (- - -) lines. Proper caulking provides good case refrigeration and sanitation.

2. Using an appropriate lifting device, lift corner case from skid and install four pipe legs. Lower corner case to floor.
3. Position corner case at end of case line-up so front bumpers and case pull-ups line up.

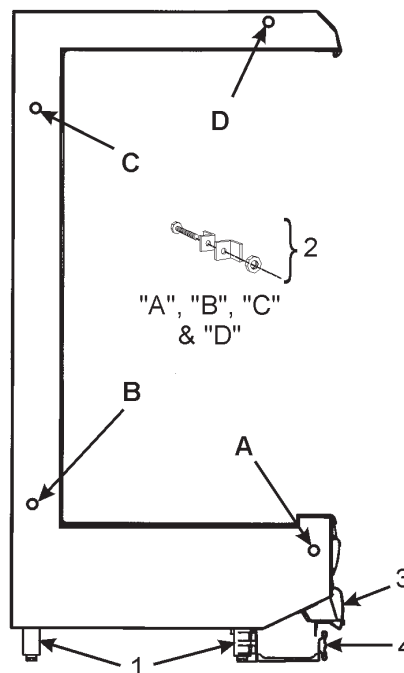

4. Adjust legs inserts in bottom of legs (1), up to 1 1/2", to align and level pull-ups and bumpers. Push corner case tight against case line-up.

CAUTION

Do not drill or use other holes through the case end for pull-ups. This may deform the case ends and could cause joint leaks and/or poor refrigeration.

5. Secure corner case to case line-up by installing pull-up bolts and mounting hardware (2) at pull-up locations (A & B) or (A, B, C & D) as shown on page 10. **NOTE:** Do not tighten any pull-up hardware until all of it has been installed. Tighten all pull-up hardware equally starting at point A and finishing at point B or D. **Do not overtighten.**
6. After running electrical wiring to case, install raceway cover (3) over raceway and secure bottom with raceway cover retainer(s) and screws.
7. Install kickplate assembly (4) by securing clips to front legs (1).

Installation & Service Manual

Trim & NSF Thermometer Installation

The joint trim and mounting hardware are shipped loose. Trim includes canopy joint trim, bumper joint trim, front cladding joint trim, raceway cover joint trim and kickplate joint trim.

The NSF product thermometer and bracket assembly is shipped loose with the case. After removing the thermometer and bracket assembly from the shipping packaging, position it on the inside of the front bottom left cutout in the partition. Secure bracket to partition with two screws.

Electrical Procedures

Electrical Considerations

CAUTION

Make sure all electrical connections at components and terminal blocks are tight. This will prevent burning of electrical terminals and/or premature component failure.

NOTE

The electrical components are located in the electrical raceway, behind the raceway cover, at the center front of the case.

Case Fan Circuit

This circuit is to be supplied by an uninterrupted, protected 120V circuit. The case fan circuit is not cycled during defrost on any of these models.

Fluorescent Lamp Circuit

Corner case lighting is supplied by PL-L folded lamps with electronic ballasts. It is controlled by a light switch in each case. The standard lighting is 1-row of horizontal lighting.

Defrost Information

See “General-UL/NSF I&S Manual” for operational descriptions for Off Time defrost control.

Defrost Control Chart

<u>Defrost Type</u>	<u>Defrosts Per Day</u>	<u>Defrost Duration (Min)</u>	<u>Term. Temp.</u>
Off Time			
N6D(IS/OS)	4	24	-----
N6DHP(IS)*	6	18	-----
N6DHP(OS)*	6	16	-----
Electric			
N6D(IS/OS)	4	24	41°F

*Models only offered with Off Time defrost.

WIRING DIAGRAMS

ELECTRICIAN NOTE - OVERCURRENT PROTECTION

120V circuits should be protected by 15 or 20 Amp devices per the requirements noted on the cabinet nameplate or the National Electrical Code, Canadian Electrical Code - Part 1, Section 28. 208V defrost circuits employ No. 12 AWG field wire leads for field connections. On remote cases intended for end to end line-ups, bonding for ground may rely upon the pull-up bolts.

The following wiring diagrams on page 12 will cover the N6D and N6DHP inside and outside corner case and defrost circuits. The lighting circuits are covered in the case circuit diagrams.

N6D(HP) Inside & Outside Dom. & Exp. (50 Hz) Corner Case Circuits



1. TYLER REFRIGERATION CLAIMS RIGHTS TO THE INFORMATION ON THIS DRAWING AND MAY NOT BE USED WITHOUT PERMISSION.
 2. THIS DRAWING IS THE PROPERTY OF TYLER REFRIGERATION.
 3. SPECIFIED OTHERWISE.
 4. ANY REVISIONS TO FINISHED PART AFTER PURCHASED.
 5. NO MANUAL REVISIONS ALLOWED.

PART TYPE N T S
 MODEL X
 FABRICATED X
 PURCHASED X
 DEPT CC X W

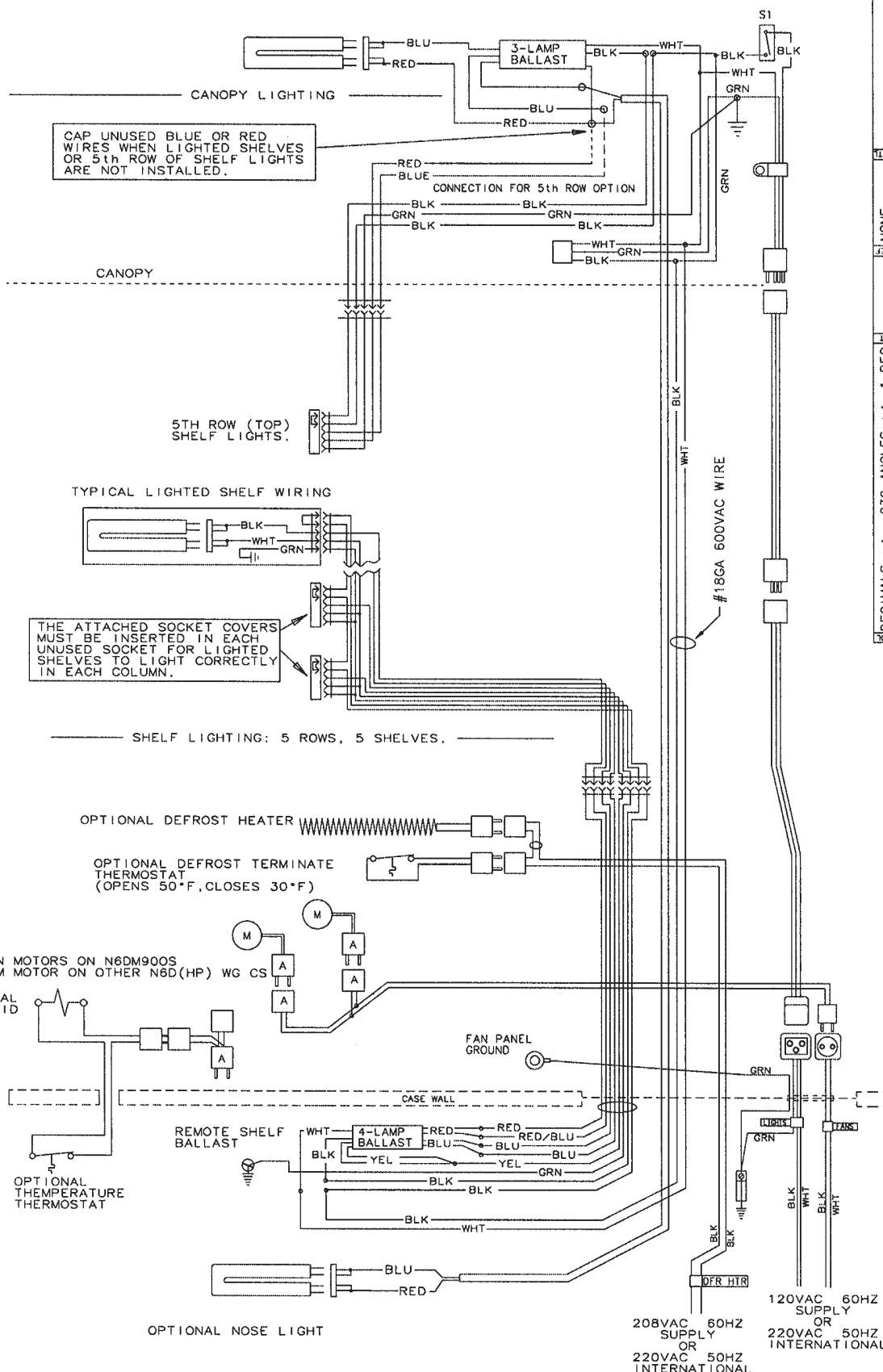

NOTE : ALL CASES MUST BE GROUNDED

REV	DESCRIPTION	DATE	BY	CHK	DATE
A	REVISED OS WIRING	31771	05DEC03	LC	AS
B	REVISED CASE WRG & DESC.	41835	19MAY05	LC	MB
C	CHANGED FAN MOTOR NUMBER	43196	22NOV05	GH	AS
DATE	1 DEG	22	22	22	22
REV	DESCRIPTION	DATE	BY	CHK	DATE
A	REVISED OS WIRING	31771	05DEC03	LC	AS
B	REVISED CASE WRG & DESC.	41835	19MAY05	LC	MB
C	CHANGED FAN MOTOR NUMBER	43196	22NOV05	GH	AS
DATE	1 DEG	22	22	22	22
REV	DESCRIPTION	DATE	BY	CHK	DATE
A	REVISED OS WIRING	31771	05DEC03	LC	AS
B	REVISED CASE WRG & DESC.	41835	19MAY05	LC	MB
C	CHANGED FAN MOTOR NUMBER	43196	22NOV05	GH	AS
DATE	1 DEG	22	22	22	22

DIAG WRG OC/ELE DFR N6D(HP) (L/M/H) I_S OS

9037682

CLEANING AND SANITATION

Component Removal and Installation Instructions for Cleaning

Shelves and Shelf Brackets

1. Remove product from shelves.
2. If shelf has a light, unplug the light cord from the socket in the rear duct panel. Completely insert socket cover in the light socket to protect the receptacle.
3. Push shelves back and then lift up and out to remove them from the shelf brackets.
4. Remove shelf brackets from slots in rear uprights.
5. After cleaning, replace in reverse order.

Bottom Trays

1. Remove product from bottom of case.
2. Grasp and lift out each lower tray from the case interior.
3. Remove tray supports from slots in front and rear ducts.
4. After cleaning, replace in reverse order.

Front Air Ducts

1. Remove bottom trays, see this page.
2. Lift out front air duct sections.
3. After cleaning, replace in reverse order.

Rear Duct Panels (Models w/o Shelf Light Sockets)

1. Remove shelves and/or bottom trays, see this page.
2. Remove mounting screws and rear duct panels from case.
3. After cleaning, replace and secure rear duct panels in reverse order.

(Models with Shelf Lights Sockets)

1. Remove shelves and bottom trays, see this page.

2. Remove mounting screws from rear duct panels.
3. Slowly lift out rear duct panel until the shelf harness connector near the top of the panel can be accessed.
4. Disconnect shelf harness connector and complete removing the rear duct panel.

WARNING

Rear duct panels with electrical receptacles can be cleaned without removing the electrical receptacles. Do not get moisture on electrical wires when cleaning under this cover. Moisture on wires could cause premature product failure and/or personal injury or death from electrical shock.

5. After cleaning, reconnect the shelf harness connector and install and secure the rear duct panels in reverse order.

Discharge Air Honeycomb

NOTE

Note position of the honeycomb grid during removal so it can be reinstalled the same way.

1. Remove screws, rear grid retainer and honeycomb grid from front of top or rear duct panel.

CAUTION

Improper installation of the honeycomb grid could result in improper air flow and/or poor refrigeration.

2. After cleaning, replace honeycomb grid as it was removed and secure with rear grid retainer and screws.

Top Duct

1. Remove shelves and shelf brackets, see this page
2. Remove screws, rear retainer plate and honeycomb grid from top of case.
3. Remove screws and top duct from case.
4. After cleaning, replace top duct and remaining components in reverse order.

Front Cladding

1. Remove kickplate and raceway cover. See "General-UL/NSF I&S Manual."
2. Remove color band, bumper and bumper retainer from the case. See "General-UL/NSF I&S Manual".
3. Remove screws from top and bottom of front cladding and remove cladding.
4. After cleaning, replace front cladding and remaining front components in the reverse order.

GENERAL INFORMATION

NSF Product Thermometer Installation

1. Unwrap the thermometer and bracket assembly shipped loose with the case.
2. Remove left front return air duct.

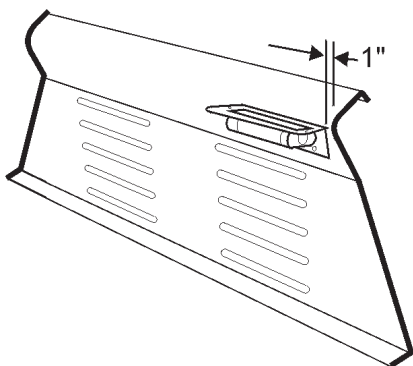

3. Position bracket 1" in from left edge and just under the bottom return air duct holes.
4. Mount the bracket to the return air duct with two self-tapping screws.
5. Replace the front return air duct.

SERVICE INSTRUCTIONS

See "General-UL/NSF I&S Manual" for fan blade & motor and color band & bumper replacement instructions.

Connecting the Refrigeration Piping and Components

WARNING

Be sure to position a flame and heat-resistant shield over the bottom of the case liner. Heat from brazing could damage the liner and/or cause personal injury or death from fire.

1. Remove screws and refrigeration piping cover from the left bottom of the case.
2. Position loose refrigeration piping and/or optional valves between the open lines in the bottom and upright of the case.

NOTE

- Make sure all sensor and thermostat wires are clear of areas being heated.
 - Mount all refrigeration lines off the floor to allow for cleaning access.
3. Apply flux to all joint ends. Starting at one end, thoroughly heat each new pipe joint and braze it together. Repeat this process until all new pipe joints have been brazed.
 4. After piping has cooled, route and connect thermostat and sensor wires through openings in the bottom of the case.

Compact Lamp Replacement

CAUTION

Shut off light switch or disconnect power supply before changing a lamp. Lighting system power and/or ballast surges can burn out adjacent lamps if power is left on.

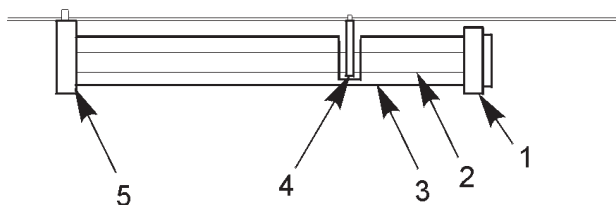

1. Remove lampshield end cap (1).
2. Gently pull down on lamp (2) and lampshield (3) to release end from retainer clip (4).
3. Unseat and slide off light shield (3) from lamp (2).
4. Carefully grasp and pull lamp (2) until it releases from the receptacle (5).
5. Insert new lamp (2) in receptacle (5) until it snaps into place.
6. Slide on lampshield (3) until it is fully seated on the receptacle (5).

NOTE

Slot in lampshield must line up with retainer clip to allow for proper lamp securing.

7. Snap lamp (2) and lampshield (3) into retainer clip (4). Install lampshield end cap (1) over open end of lampshield (3).

Discharge Grid Replacement

1. Remove screws rear grid retainer and discharge grid.

NOTE

Note position of the honeycomb grid during removal so new grid can be reinstalled the same way.

CAUTION

Improper installation of the honeycomb grid could result in improper air flow and/or poor refrigeration.

2. Position new discharge grid so front bottom lip is resting on lower lip of front grid retainer. Install and secure discharge grid with rear grid retainer and screws.

PARTS INFORMATION

Operational Parts List

Case Usage	Domestic
Electrical Circuit	115 Volt 60 Hertz
Case Size	All Dairy Corners
Fan Motors	
(N6DL45IS/45OS/N6DM45OS/N6DH45IS/ 45OS/N6DHPL30IS)	5243498 9 Watt
(N6DL30OS/N6DM90OS)	9458939 16 Watt
(N6DL90IS/N6DM90IS/N6DH90IS/N6DHPL45IS/ 45OS/90IS/N6DHPM45IS/45OS/90IS)	9458944 23 Watt
Fan Motor Brackets	
(N6DL45IS/N6DH45IS)	5235087
(N6DHPL30IS)	5962268
(All Other N6D & N6DHP Corner Cases)	5205112
Fan Bracket Plate	9041077
(All Corner Cases without 23W Motors)	
Fan Blades	
(7.00" 25° 5B)(N6DHPL30IS)	9041013
(8.75" 30° 5B)(N6DL45IS/N6DH45IS)	9407319
(8.75" 35° 5B)	5643563
(All Other N6D & N6DHP Corner Cases)	
Compact Lamp Ballast (Cases w/Lights)	
(canopy)(N6DHPIS)	5991029
(canopy)(All Other N6D & N6DHP Corner Cases)	5991030
(shelf - 4 rows)	5966635
Compact Lampholder (Canopy or Shelf)	9450238
Compact Lamp Clip (Canopy or Shelf)	9450239
Compact Lampsheild	
(Canopy or Shelf)(All Inside Corner Cases)	9410789
(Canopy or Shelf)(All Outside Corner Cases)	9410791
NSF Product Thermometer	5967100

For information on operational parts not listed above contact the TYLER Service Parts Department.

Installation & Service Manual

Cladding and Optional Trim Parts Lists

N6D/N6DHP Corner Models

Item	Description	30°IS	30°OS	45°IS	45°OS	90°IS	90°OS
1	Canopy Hood, Ptd.	9456672	9459385	9330019	9455427	9457690	9458145
2.	Canopy Joint Trim, Ptd.	9028066	9028067	9028068	9028069	9028072	9028073
3	Bumper Joint Trim	----- color per order -----					
4	Bumper Retainer	----- color per order -----					
5	Color Band, Ptd.	9456674	9459386	9330013	9455218	9450541	9458135
6	Bumper	----- color per order -----					
7	Front Cladding Joint Trim, Ptd.	----	9459466 LH 9459465 RH	9454937	9455474	9457859	9458433
8	Front Cladding, Ptd.						
	(N6DHPL30IS)	9456673	----	----	----	----	----
	(N6DL30OS)	----	9459388	----	----	----	----
	(N6D(HP)L45IS)	----	----	9454922	----	----	----
	(N6DHPM45IS)	----	----	9457293	----	----	----
	(N6D(HP)H45IS)	----	----	9452085	----	----	----
	(N6D(HP)L45OS)	----	----	----	9455505	----	----
	(N6D(HP)M45OS)	----	----	----	9455855	----	----
	(N6D(HP)H45OS)	----	----	----	9455398	----	----
	(N6D(HP)L90IS)	----	----	----	----	9458477	----
	(N6D(HP)M90IS)	----	----	----	----	9457665	----
	(N6DH90IS)	----	----	----	----	9458471	----
	(N6DM90OS)	----	----	----	----	----	9458137
9	Raceway Cover Joint Trim, Ptd.	----	9459467	9452078	9455202	9457863	9458445
10	Raceway Cover	----- color per order -----					
11	Kickplate Joint Trim, Ptd.	9452763	9452766	9452769	9452772	9452781	9452784
12	Kickplate, Ptd.	9454869	9459379	9454610	9455501	9454861	9458427
13	Kickplate Support Assy.	9456665	9459365	9330085	9455460	9457659	9458438
14	Pipe Leg, Std. (1.50" X 4.00")	9330018(4)	9330018(4)	9330018(4)	9330018(4)	9330018(4)	9330018(4)