

# TYLER

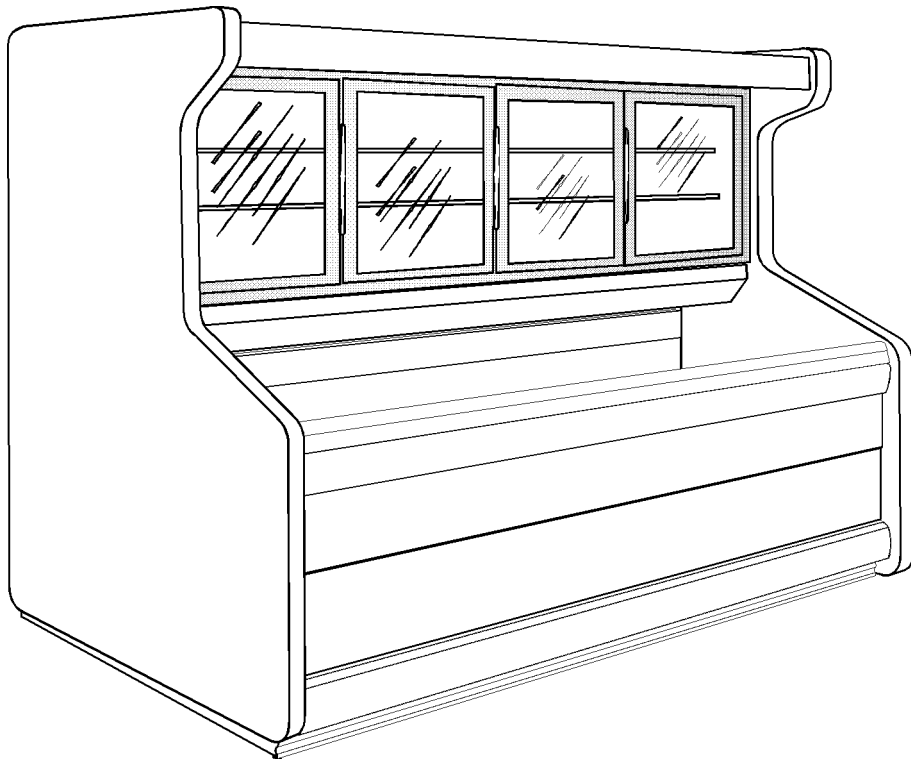

## Installation & Service Manual



### L2TG

#### COMBINATION MERCHANDISER

#### Frozen Food or Ice Cream Glass Door/Open Well Cases

This manual has been designed to be used in conjunction with the General Installation & Service Manual.

**Save the Instructions in Both Manuals for Future Reference!!**

This merchandiser conforms to the Commercial Refrigeration Manufacturers Association Health and Sanitation standard CRS-S1-97.

PRINTED IN U.S.A.	Specifications subject to change without notice.	REPLACES EDITION 7/99	ISSUE DATE 8/99	PART NO. 9031248	REV. B
-------------------	--	-----------------------	-----------------	------------------	--------

## CONTENTS

	<u>Page</u>
<b>Specifications</b>	
L2TG Specification Sheets .....	4
Line Sizing Requirements .....	(See General I&S Manual)
<b>Pre-installation Responsibilities</b> .....	(See General I&S Manual)
<b>Installation Procedures</b>	
<b>Carpentry Procedures</b> .....	7
Case Line-Up .....	7
Trim Installation/Alignment .....	9
<b>Plumbing Procedures</b> .....	(See General I&S Manual)
<b>Refrigeration Procedures</b> .....	10
L2TG Application Requirements .....	10
<b>Electrical Procedures</b> .....	10
Electrical Considerations .....	10
<b>Defrost Information</b> .....	11
Defrost Control Chart .....	11
<b>Installation Procedure Check Lists</b> .....	(See General I&S Manual)
<b>Wiring Diagrams</b> .....	11
L2FGU Upper Case Circuits with Electric Defrost (208V) .....	12
L2FGU Upper Case Circuits with Gas Defrost (208V) .....	13
L2FGU Upper Case Circuits with Electric Defrost (120V-GIANT) ..	14
L2NGU Upper Case Circuits (208V) .....	15
L2FL/L2CL Lower Case Circuits with Electric Defrost (208V) .....	16
L2FL/L2CL Lower Case Circuits with Gas Defrost (208V) .....	17
L2CL Lower Case Circuits with Electric Defrost (120V-GIANT) ...	18
L2TG Case Lighting Circuits .....	19
<b>Cleaning and Sanitation</b> .....	(See General I&S Manual)
<b>Service Instructions</b>	
<b>Preventive Maintenance</b> .....	(See General I&S Manual)
<b>Light Servicing</b> .....	20
Ballast and Lighting Locations .....	20
Lamp Replacement .....	20
Electronic Ballast Replacement (Prism Lighting) .....	22

	<b>Page</b>
<b>Upper Case Door Servicing</b> .....	23
Door Removal .....	24
Reversing Door Hardware .....	25
Reversing Frame Hardware .....	29
Door Handle Replacement .....	26
Door and Mullion Heater Replacement .....	26
Door Installation .....	27
<b>Case Defrost &amp; Drain Pan Heater Replacement</b> .....	28
<b>Fan Locations and Access</b> .....	29
<b>Fan Blade and Motor Replacement</b> .. (See General I&S Manual)	
<b>Anti-Sweat Replacement</b> .....	29
<b>Optional Sensor Locations and Access</b> .....	30
<b>Parts Information</b>	
Cladding and Trim Parts List .....	32
Operational Parts List .....	34
<b>TYLER Warranty</b> .....	(See General I&S Manual)

The following Frozen Food, Ice Cream and Normal Temp Combination Merchandiser models are covered in this manual:

<b>MODEL</b>	<b>DESCRIPTION</b>
L2TG	8' & 12' COMBINATION FROZEN FOOD/ICE CREAM MERCHANDISER
L2FGU	8' & 12' GLASS DOOR FROZEN FOOD/ICE CREAM UPPER MERCHANDISER
L2NGU	8' & 12' GLASS DOOR NORMAL TEMP UPPER MERCHANDISER
L2FL	8' & 12' OPEN WELL FROZEN FOOD LOWER MERCHANDISER
L2CL	8' & 12' OPEN WELL ICE CREAM LOWER MERCHANDISER

**SPECIFICATIONS**

**L2TG Combination Merchandiser Specification Sheets**

MODEL	L2FGU/L2NGU (UPPER)			L2FL (LOWER)	L2CL (LOWER)
	FROZEN FOOD	ICE CREAM	MED TEMP	FROZEN FOOD	ICE CREAM
BTUH/FT	385	424	325	410	470
SUCTION*	-15F	-20F	+20F	-20F	-30F
ENTER AIR*	-4F	-9F	+30F	-14F	-20F

THE ABOVE RATINGS ARE FOR COMPRESSOR SELECTION ONLY. FOR ENERGY CALCULATION DATA REFER TO THE ENERGY SECTION.

NOTE: FOR COMPRESSOR SIZING INFORMATION REFER TO THE "GOLD" SECTION & THE LINE SIZING INFORMATION REFER TO THE "BUFF" SECTION OF THE TYLER SPECIFICATION GUIDE.

UPPER CASE WITH 208 VOLT DEFROST (AMPS)												
FT	8	12	16	20	24	28	32	36	40	44	48	52
FF/IC 1PH	7.7 TG-30	11.5 TG-30	15.4 TG-30	19.2 TG-30	23.0 TG-30	26.9 TG-40	30.8 TG-40	34.6 TG-50	42.2 TG-50	N/A	N/A	N/A
FF/IC 3PH	N/A	N/A	13.3 TG-30	16.6 TG-30	19.9 TG-30	16.6 TG-30	19.9 TG-30	19.9 TG-30	23.3 TG-30	26.6 TG-40	29.9 TG-40	33.3 TG-50
LOWER CASE WITH 208 VOLT DEFROST (AMPS)												
FF 1PH	7.7 TG-30	11.5 TG-30	15.4 TG-30	19.2 TG-30	23.0 TG-30	27.0 TG-40	30.7 TG-40	34.5 TG-50	38.4 TG-50	N/A	N/A	N/A
FF 3PH	N/A	N/A	13.3 TG-30	16.6 TG-30	19.9 TG-30	16.6 TG-30	19.9 TG-30	19.9 TG-30	23.3 TG-30	26.6 TG-40	29.9 TG-40	33.6 TG-50
IC 1PH	16.5 TG-30	24.6 TG-40	33.0 TG-50	41.1 TG-50	N/A	N/A	N/A	N/A	N/A	N/A	N/A	N/A
IC 3PH	N/A	N/A	28.6 TG-40	35.6 TG-50	42.6 TG-50	35.6 TG-50	42.6 TG-50	42.6 TG-50	35.6/35.6 TG-50-50	42.6/35.6 TG-50-50	42.6/42.6 TG-50-50	42.6/35.6 TG-50-50
CASE-TO-CASE SUCTION SUB-FEED BRANCH LINE SIZING												
R404A UPPER	7/8"	7/8"	7/8"	7/8"	7/8"	7/8"	1 1/8"	1 1/8"	1 1/8"	1 1/8"	1 1/8"	1 1/8"
R404A LOWER	7/8"	7/8"	7/8"	1 1/8"	1 1/8"	1 1/8"	1 1/8"	1 1/8"	1 1/8"	1 1/8"	1 1/8"	1 1/8"

DEFROST CONTROL				PRESSURE SETTINGS			EPR SETTINGS	
PER DAY	MODE	TIME	TERM.		CUT IN	CUT OUT	R22	R404A
1	ELECT - FF	60 MIN.	50F	FF	18-22# @ R22	8-11# @ R22	11#	18#
2	(UPPER) - IC	60 MIN.	50F	IC	15-20# @ R22	4-8# @ R22	8#	14#
1	TIME OFF - MT	60 MIN.	---	MT	63# @ R22	29-38# @ R22	38#	---
1	ELECT - FF/IC (LOWER)	36 MIN.	50F	FF	15-20# @ R22	4-8# @ R22	8#	14#
				IC	12-18# @ R22	1-5# @ R22	3#	8#
2	HOT GAS - FF	18-20 MIN.	70F	FF	23# @ R404A	14# @ R404A	11#	18#
	(UPPER) - IC	20-25 MIN.		IC	19# @ R404A	9# @ R404A	8#	14#
2-3	HOT GAS - FF	16-22 MIN.	70-75F	FF	22-30# @ R404A	9-14# @ R404A	8#	14#
	(LOWER) - IC	16-20 MIN.		IC	15-22# @ R404A	5-10# @ R404A	3#	8#

CASE BTUH REQUIREMENTS are calculated to produce approximately the indicated entering air temperature with absolute maximum operating ambient limits of 75F & 55RH.

The information contained herein is based on technical data and tests which we believe to be reliable and is intended for use by persons having technical skill, at their discretion and risk. Since conditions of use are outside Tyler's control, we can assume no liability for results obtained or damages incurred through the applications of the data presented. SPECIFICATIONS ARE SUBJECT TO CHANGE WITHOUT NOTICE.

L2TG Combination Merchandiser (120 Volts)

MODEL	L2FGU (UPPER)	L2CL (LOWER)
USAGE	ICE CREAM	ICE CREAM
BTUH/FT	424	470
SUCTION°	-20F	-30F
ENTER AIR°	-9F	-20F

THE ABOVE RATINGS ARE FOR COMPRESSOR SELECTION ONLY. FOR ENERGY CALCULATION DATA REFER TO THE ENERGY SECTION.

NOTE: FOR COMPRESSOR SIZING INFORMATION REFER TO THE "GOLD" SECTION & THE LINE SIZING INFORMATION REFER TO THE "BUFF" SECTION OF THE TYLER SPECIFICATION GUIDE.

UPPER CASE WITH 120 VOLT DEFROST (AMPS)															
FT	8	12	16	20	24	28	32	36	40	44	48	52	56	60	64
IC - 1PH	13.3	20	26.6	33.3	40	46.6	53.3	60	66.6	73.3	80	86.6	93.3	100	106.6
LOWER CASE WITH 120 VOLT DEFROST (AMPS)															
IC - 1PH	28.7	42.7	57.4	71.4	85.4	100.1	114.8	128.8	142.8	156.8	170.8	185.5	200.2	214.9	229.6
CASE-TO-CASE SUCTION SUB-FEED BRANCH LINE SIZING															
R404A UPPER	7/8"	7/8"	7/8"	7/8"	7/8"	7/8"	1 1/8"	1 1/8"	1 1/8"	1 1/8"	1 1/8"	1 1/8"	1 3/8"	1 3/8"	1 3/8"
R404A LOWER	7/8"	7/8"	7/8"	1 1/8"	1 1/8"	1 1/8"	1 1/8"	1 1/8"	1 1/8"	1 1/8"	1 1/8"	1 1/8"	1 1/8"	1 3/8"	1 3/8"

DEFROST CONTROL				PRESSURE SETTINGS			EPR SETTINGS	
PER DAY	MODE	TIME	TERM.		CUT IN	CUT OUT	R22	R404A
1	ELECT / IC (UPPER)	60 MIN.	50F	IC	15-20# @ R22	4-8# @ R22	8#	14#
1	ELECT / IC (LOWER)	36 MIN.	50F	IC	12-18# @ R22	1-5# @ R22	3#	8#

120V CASE CIRCUITS: This optional case requires a separate 120V circuit for fans, lights, anti-sweats and Electric Defrost in the upper case. It also requires a separate 120V circuit for fans, anti-sweats and Electric Defrost in the lower case. Lighting for whole case comes from the upper case. Anti-sweat heat is not required 100% of the time in most stores and the use of a Energy Saver control to cycle this circuit as required is strongly recommended.

CASE BTUH REQUIREMENTS are calculated to produce approximately the indicated entering air temperature with absolute maximum operating ambient limits of 75F & 55RH.

The information contained herein is based on technical data and tests which we believe to be reliable and is intended for use by persons having technical skill, at their discretion and risk. Since conditions of use are outside Tyler's control, we can assume no liability for results obtained or damages incurred through the applications of the data presented. SPECIFICATIONS ARE SUBJECT TO CHANGE WITHOUT NOTICE.

L2TG Combination Merchandiser

208V CASE CIRCUITS: In addition to the 208V Defrost Circuit, there is a separate 120V circuit for fans, lights and anti-sweats in the upper and lower cases. Lighting for whole case comes from the upper case. Anti-sweat heat is not required 100% of the time in most stores and the use of a Energy Saver control to cycle this circuit as required is strongly recommended.

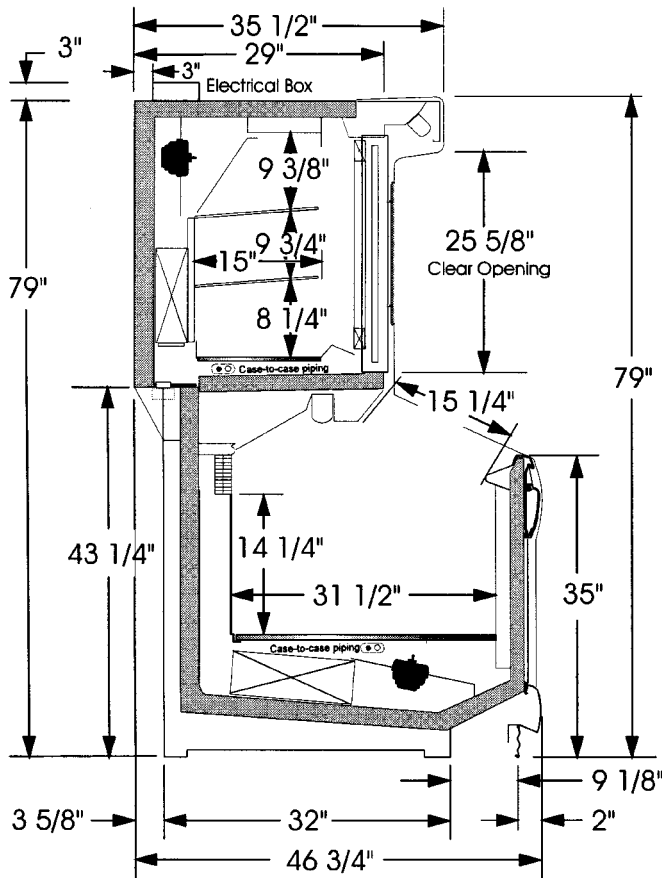

FLOOR PLAN FOR COMBINATION CASE

120 VOLT ELECTRICAL DATA (AMPS)				
CASE SIZE	STD. FANS ELEC/GAS	ES FANS ELEC/GAS	ANTI-SWEATS (FF/IC) (MT)	
FT	UPPER SECTION			
8	1.0	---	3.2	2.1
12	1.5	---	4.7	3.0
FT	LOWER SECTION			
8	1.0/3.1	0.7/2.8	3.5	---
12	1.5/4.2	1.1/3.8	4.9	---

120 VOLT LIGHTING DATA (AMPS)	
CASE SIZE (FT)	UPPER CASE LIGHTING
8	4.5
12	5.1

**STUB-UP NOTES:** One floor drain can serve up to two cases per drain. One electrical stub-up can serve a number of cases depending on the circuits required - utilizing the continuous wire raceway(s) on the front of the cases. One refrigeration stub-up can serve several or all cases on a line-up with case-to-case piping.

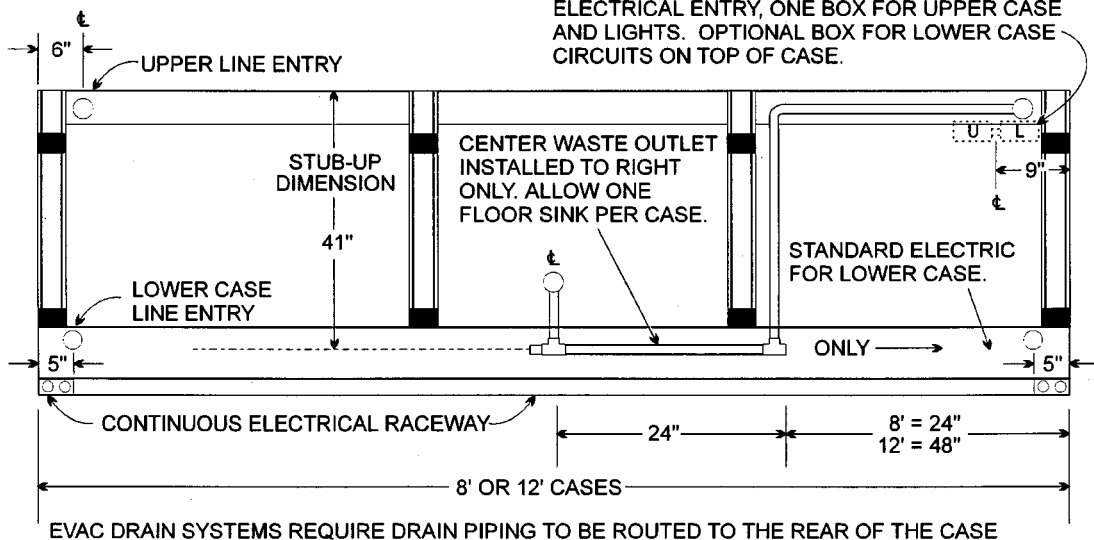

ELECTRICAL ENTRY, ONE BOX FOR UPPER CASE AND LIGHTS. OPTIONAL BOX FOR LOWER CASE CIRCUITS ON TOP OF CASE.

## INSTALLATION PROCEDURES

### Carpentry Procedures

#### Case Line-Up

Before starting the case line-up, see "Refrigeration Procedures" in this manual, review the store layout floorplans and survey the areas where case line-ups are going to be installed.

#### **WARNING**

These cases are very heavy and require two or more people to move and/or position them. Improper handling of these cases could result in personal injury.

#### **NOTE**

Allow at least 3" of air space between the top back of these cases and store walls or other cases to minimize possible condensation problems. Forced ventilation might be necessary in some situations.

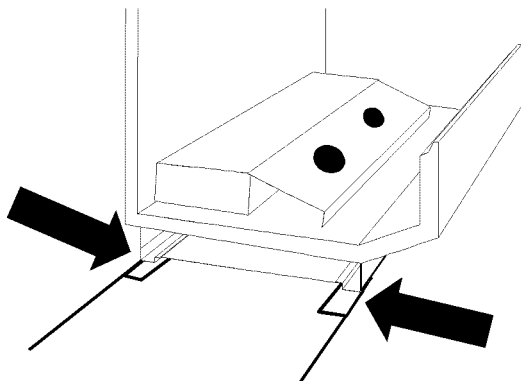

1. Snap chalk lines where the front and rear base rails of the cases are to be located for the entire line-up.

#### **NOTE**

Front and rear edges of base rails should always be used to line-up cases. 6" shims allow adjoining ends of cases to be shimmed together.

2. Locate highest point on chalk lines as a reference for determining the number of shims to be placed under the case base rails. Position first case at highest point on the chalk lines and shim case supports as required. Check leveling at hand rails and top of case and back of case.

#### **CAUTION**

Shipping braces should only be removed from case ends that are to be joined. This protects the cases from possible damage during the line-up procedure.

#### **NOTE**

A foam gasket is factory installed on one end of the case. This gasket fits into a groove on the adjoining case when cases are pulled together. Do not depend on the foam gasket alone to make a good seal!

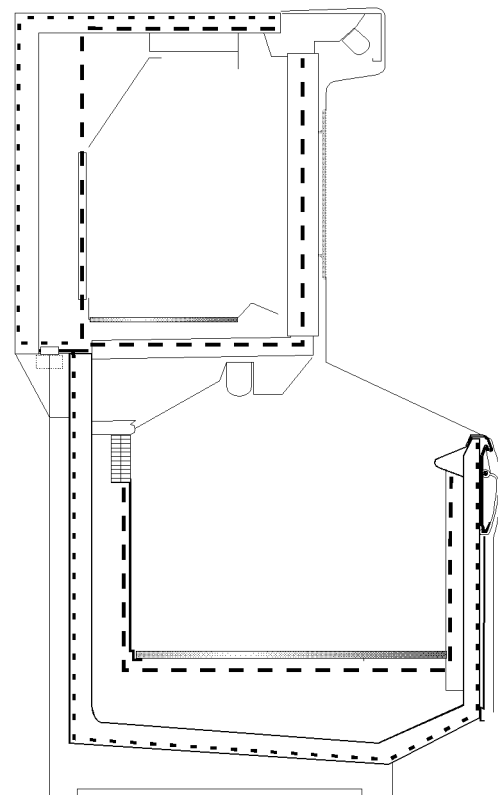

3. Apply two heavy beads of caulking compound from the Filler Kit to the end of case at dotted (. . .) and dashed (- - -) lines. Proper caulking provides good case refrigeration and sanitation.

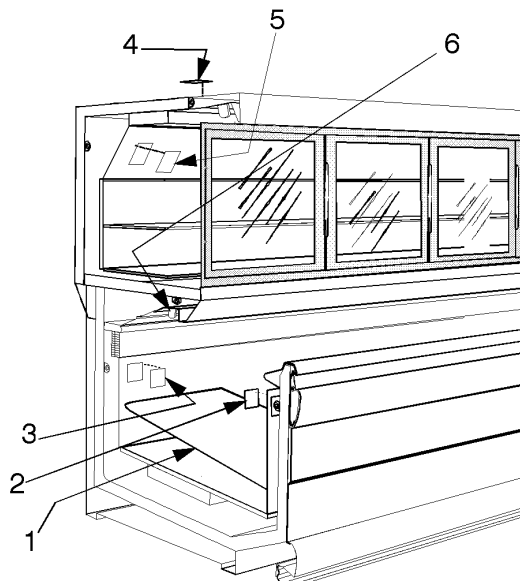

4. Remove the following parts from the adjoining ends of both cases. The bottom tray (1), front pull-up access cover (2) and rear pull-up access cover (3) from the lower case. The top pull-up access cover (4), top rear pull-up access cover (5) and lower the bottom light channel (6) from the upper case.

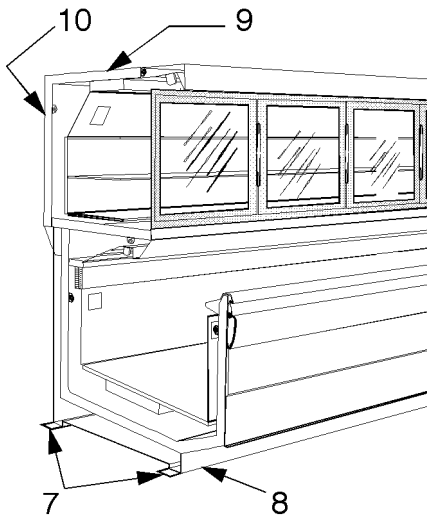

5. Push cases tightly together making sure the pull-ups are aligned.
6. Add shims (7), as required, under the adjoining case base rails (8). Check leveling at top of case (9), and back of case (10).

**CAUTION**

Do not drill or use other holes through the case end for pull-ups. This may deform the case end and could cause joint leaks and/or poor refrigeration.

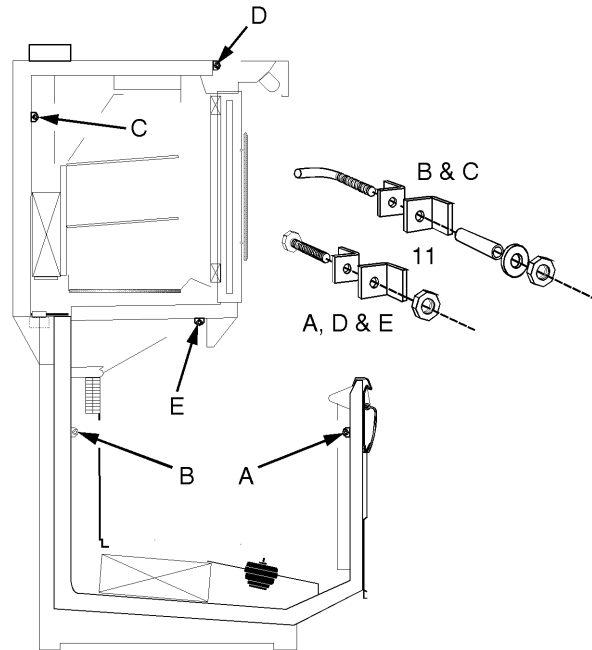

7. Position all pull-up bolts and mounting hardware (11) at pull-up locations A, B, C, D, and E. Do not tighten any pull-up hardware until all of it has been installed. Tighten all pull-up hardware equally starting at point A and finishing at point E. **Do not overtighten.**
8. Install the bottom light channel (6) and top rear and top pull-up access covers (5 & 4) on the upper case. Install the rear and front pull-up access covers (3 & 2), and bottom tray (1) on the lower case.
9. Remove shipping tape from fluorescent lamps.



Trim Installation/Alignment

Horizontal & Vertical Joint Trim Installation

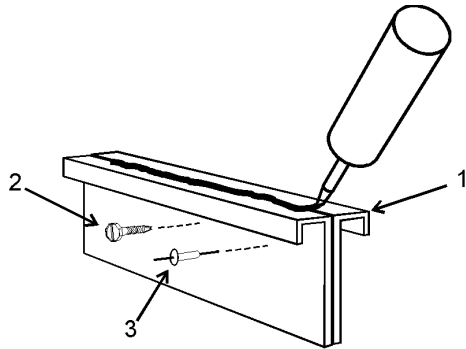

1. Apply bead of caulking compound from the Filler Kit to the top of each horizontal joint (1). If gap at horizontal joint is too large, pull together with sheet metal screws (2) or pop-rivets (3).

**NOTE**

If additional sealing is preferred, 2" wide duct tape can be applied to the top of the internal bottom joint between cases. The tape will be covered by the horizontal joint trim. Duct tape is not furnished.

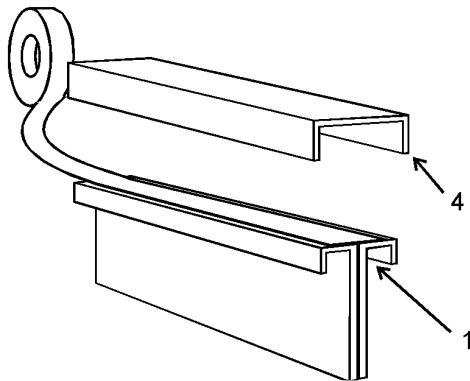

2. Apply sealer to horizontal joint trim (4) and install joint trim (4) on the horizontal joint (1).

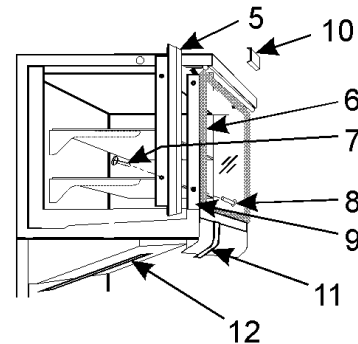

3. Position vertical joint trim (5) in front upper case line-up joint (6) and secure with two screws (7) and screw nuts (8) through adjoining upper case door frames (9).
4. Install canopy joint trim (10), top front cladding joint trim (11) and cover well joint trim (12) with mounting hardware.

**NOTE**

See "General I&S Manual" for bumper, color band, raceway cover and kickplate installation instructions.

## Refrigeration Procedures

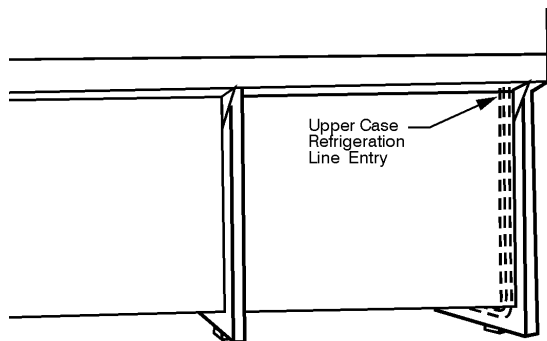

The upper case requires the installation of refrigeration lines from the refrigeration stub-ups on the rear of the case to the front of the lower case.

### NOTE

See "General I&S Manual" for all other refrigeration procedure information.

### L2TG Upper Case Application Requirements

#### Temperature Control Strategy

- A suction stop EPR valve is the preferred method for maintaining temperature control on parallel compressor system applications.
- When using a thermostat and liquid line solenoid for temperature control, the maximum line-up length that may be controlled is 24 feet.
- The discharge air temperature shall be maintained between -3°F to -5°F for frozen food applications and between -10°F to -12°F for ice cream applications.

#### Temperature Sensor Locations

- The sensor used for temperature control shall be located in the discharge air.
- If a case controller is used, the sensor used for defrost termination **MUST** be insulated and located where the standard defrost termination klixon is located. If a case controller is used and the case is defrosted using electric heaters, the defrost termination klixon must be replaced with a 70°F fail safe klixon. This meets the safety requirements.

#### Defrost Control Strategy

- High door openings loads associated with high food product sales may require two defrost periods per 24 hour period.
- Pumping down the refrigeration circuit at the beginning of the defrost period is not recommended.

## Electrical Procedures

### Electrical Considerations

#### CAUTION

**Make sure all electrical connections are tight. This prevents burning of electrical terminals and/or premature component failure.**

### NOTE

An electrical box on top of the case houses the electrical wiring for the upper case and case lighting. All other electrical wiring and components can be found in the raceway at the bottom of the lower case. All raceway covers will be shipped loose.

#### Case Fan Circuits

All fan circuits are to be supplied by an uninterrupted, protected 120V circuit. At case start-up, the upper case fans will not come on until the fan delay thermostat on the coil senses 20°F. After the upper case has been running, the fan operation is interrupted by the defrost relay whenever the defrost cycle is initiated. The defrost relay activates the defrost and drain pan heaters at the same time it shuts off the fans. After defrost, the defrost and drain heaters will shut off and refrigeration will resume.

### NOTE

**The upper case fans will not restart until the coil temperature reaches 20°F at the fan delay thermostat.**

The lower case fan circuit is not cycled, except when equipped for gas defrost. On gas defrost cases the fan circuit is controlled by a 50/30 klixon.

**NOTE**

With gas defrost, the fans will not start until the coil temperature reaches 30°F at the fan delay thermostat.

**Fluorescent Lamp Circuit**

The standard case lighting system is T-8 electronic lamps. The standard lighting is 1-row of canopy lights, Prism lighting behind doors, and 1-row of horizontal lights above the lower well.

**CAUTION**

The light switch should be left off if refrigeration is turned off for periods longer than normal defrosting times. This prevents possible distortion and/or damage to non-metal parts from lighting heat.

**Anti-Sweat Circuit**

Upper cases have anti-sweat heaters in and around the doors. Lower cases have four anti-sweat heaters. All anti-sweat heaters are wired directly to the main power supply so they can operate at all times.

**Defrost Information**

See "General I&S Manual" for operational descriptions for each type of defrost control.

**Defrost Control Charts**

**L2TG Defrost Option Settings**

Defrost Type	Defrosts Per Day	Defrost Duration (Min)	Term. Temp.
<b>L2FGU (UPPER)</b>			
Electric (FF)	1	60	50°F
Electric (IC)	2	60	50°F
Gas (FF)	2	18-20	70°F
Gas (IC)	2	20-25	70°F
Off Time (NT)	1	60	----
<b>L2FL/L2CL (LOWER)</b>			
Electric (FF)	1	60	50°F
Electric (IC)	1	36	50°F
Gas (FF)	2-3	16-22	70-75°F
Gas (IC)	2-3	16-20	70-75°F

All klixons are located on the right end of the evaporator coil. The diagram shows the location for each defrost type that uses a klixon.

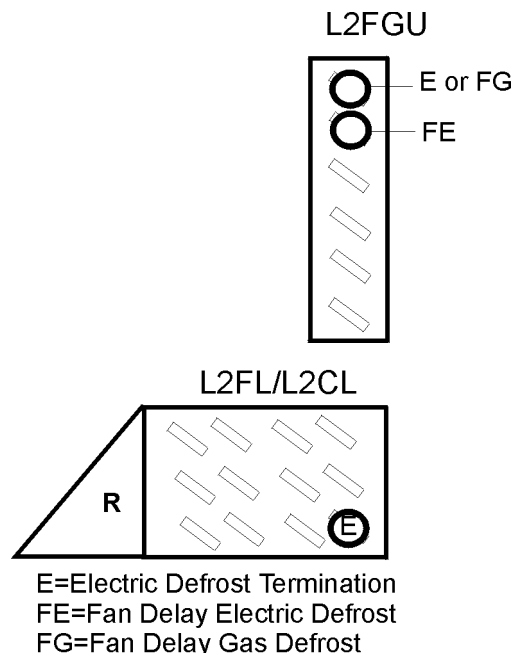

**NOTE**

The termination thermostats for gas defrost are located next to the bypass check valves.

**CAUTION**

If electronic sensors are used in place of the klixons, the sensors must be located in the same location as the klixons for that defrost type. Any other locations will effect the refrigeration efficiency of the case.

**WIRING DIAGRAMS**

**ELECTRICIAN NOTE - OVERCURRENT PROTECTION**

120V circuits should be protected by 15 or 20 Amp devices per the requirements noted on the cabinet nameplate or the National Electrical Code, Canadian Electrical Code - Part 1, Section 28. 208V defrost circuits employ No. 12 AWG field wire leads for field connections. On remote cases intended for end to end line-ups, bonding for ground may rely upon the pull-up bolts.

The wiring diagrams on the following pages 12 thru 19 will cover the L2TG upper and lower case circuits and lighting circuits.

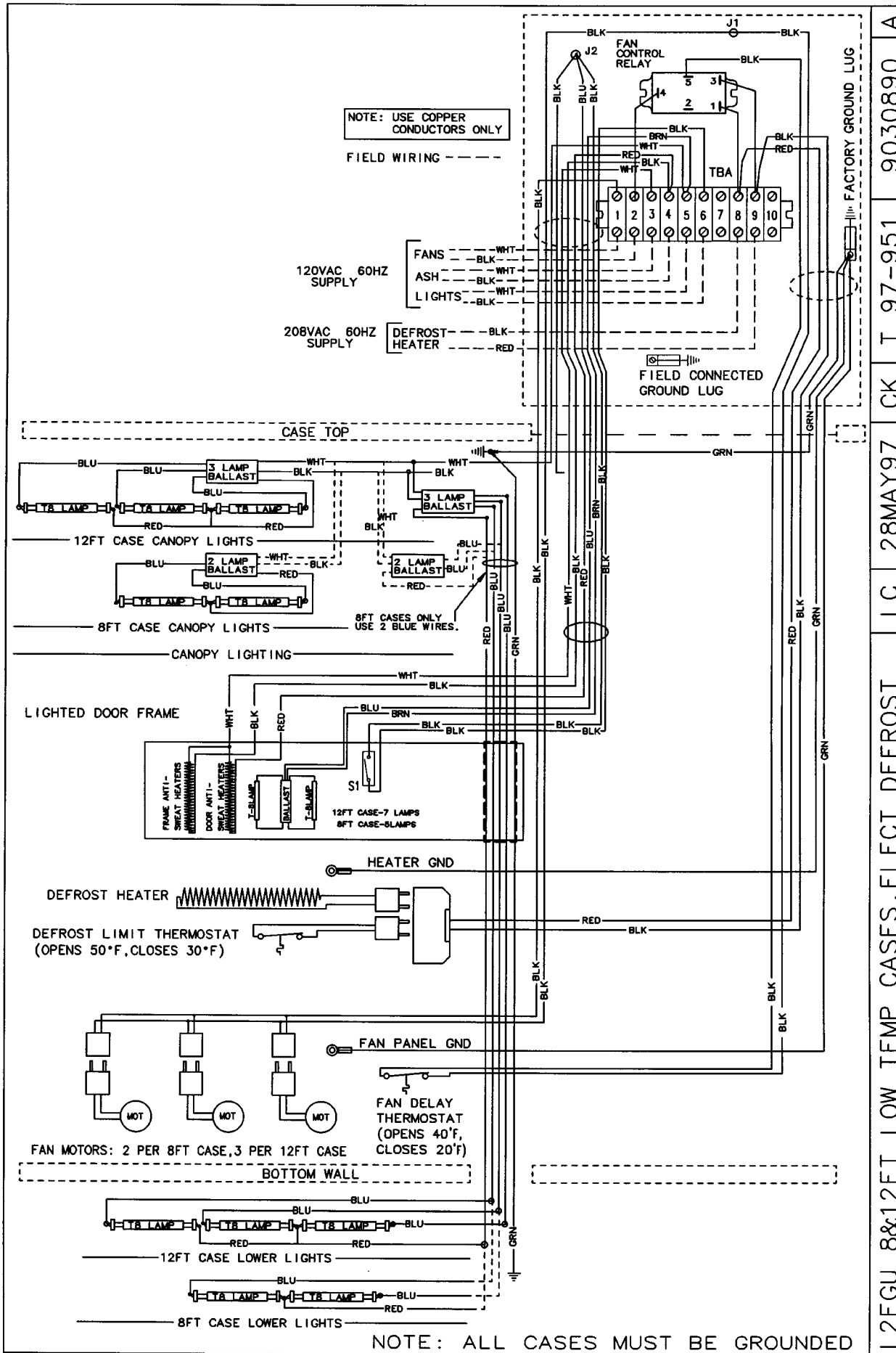

L2FCU 8&12FT LOW TEMP CASES, ELECT DEFROST LC 28MAY97 CK T 97-951 9030890 A

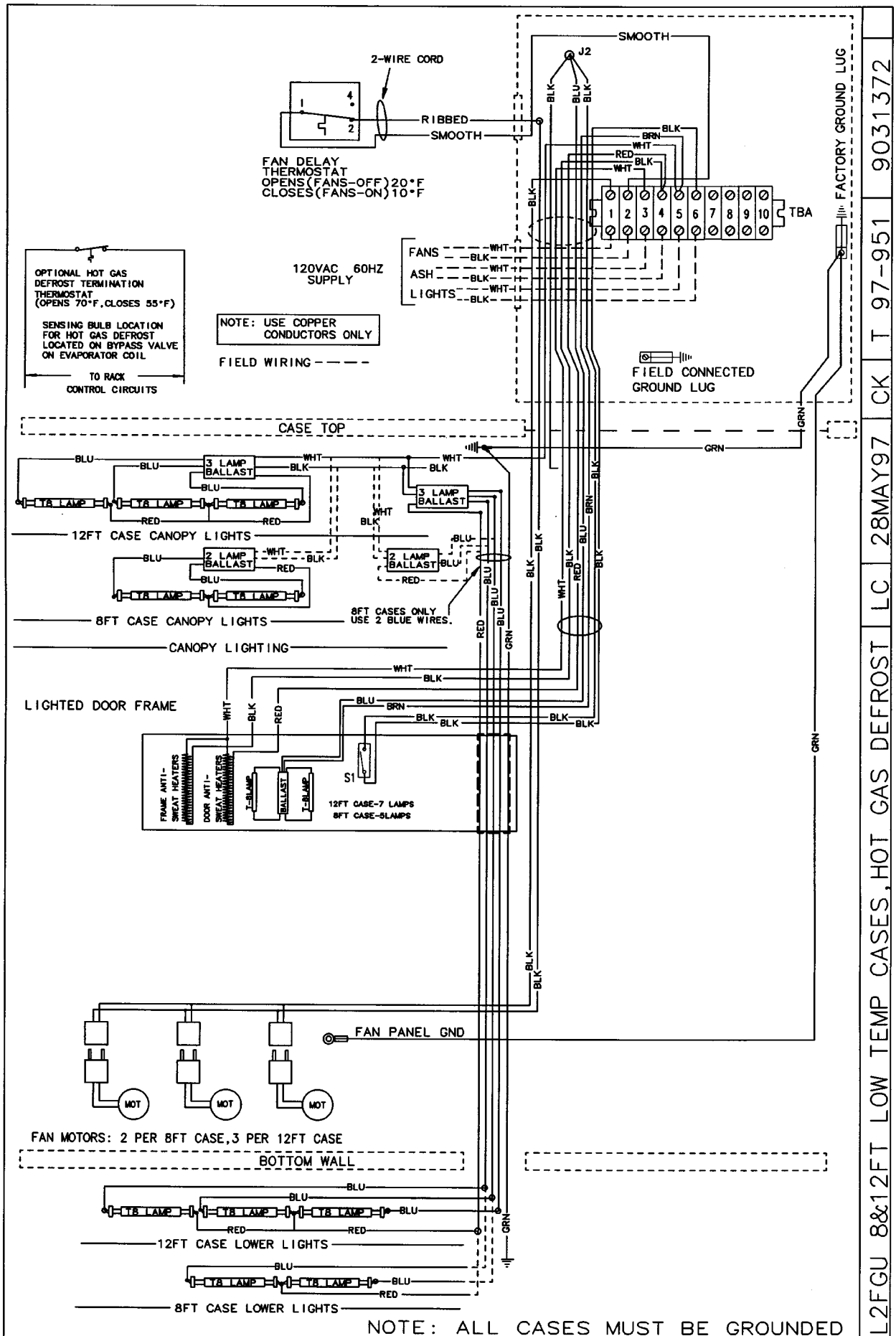

L2FGU 8&12FT LOW TEMP CASES, HOT GAS DEFROST LC 28MAY97 CK T 97-951 9031372

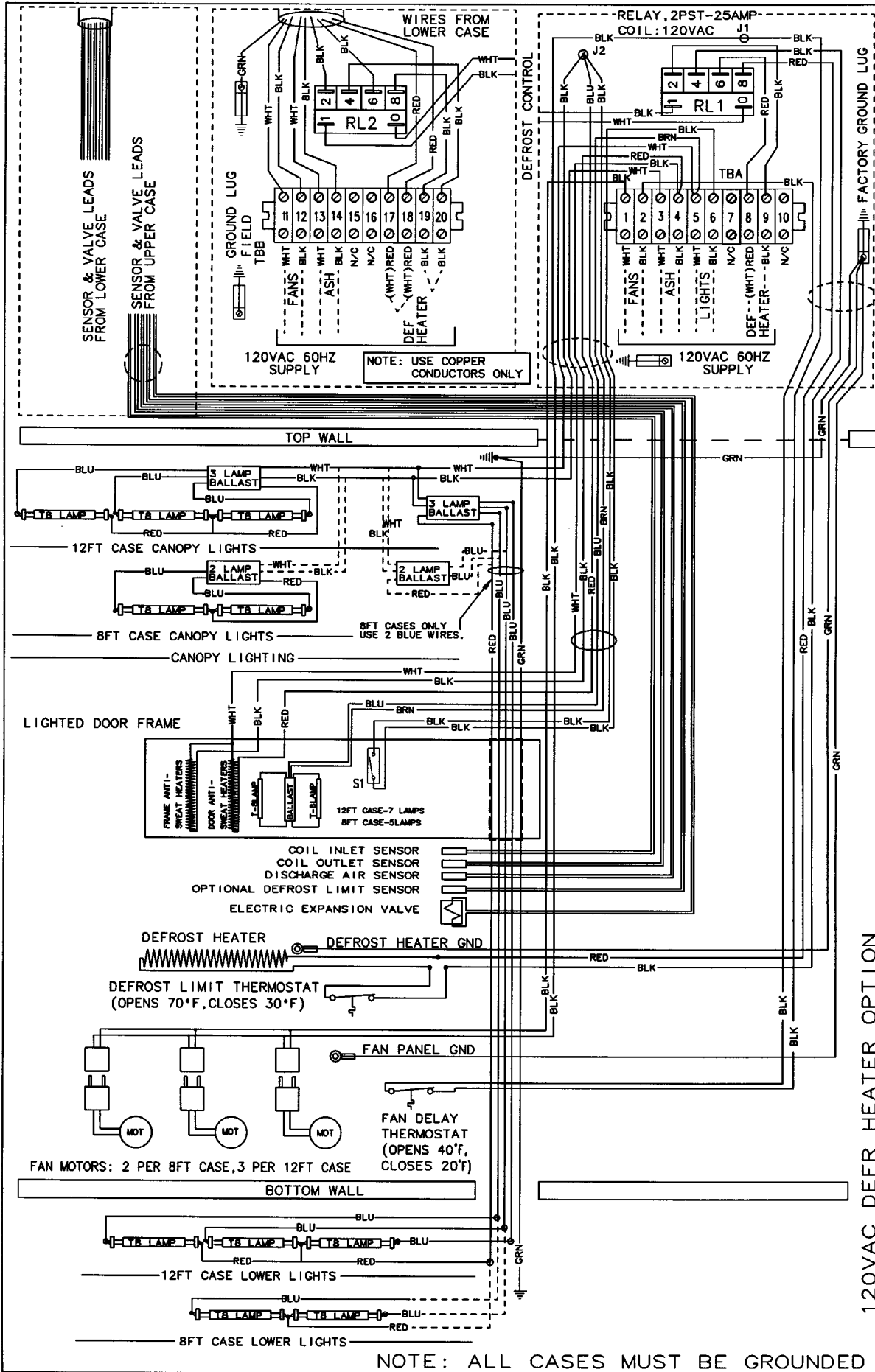

B  
5646409  
LC 28MAY97 CK T 97-951  
120VAC DEFR HEATER OPTION  
L2FGU 8&12FT W/ SENSORS & EE VALVE

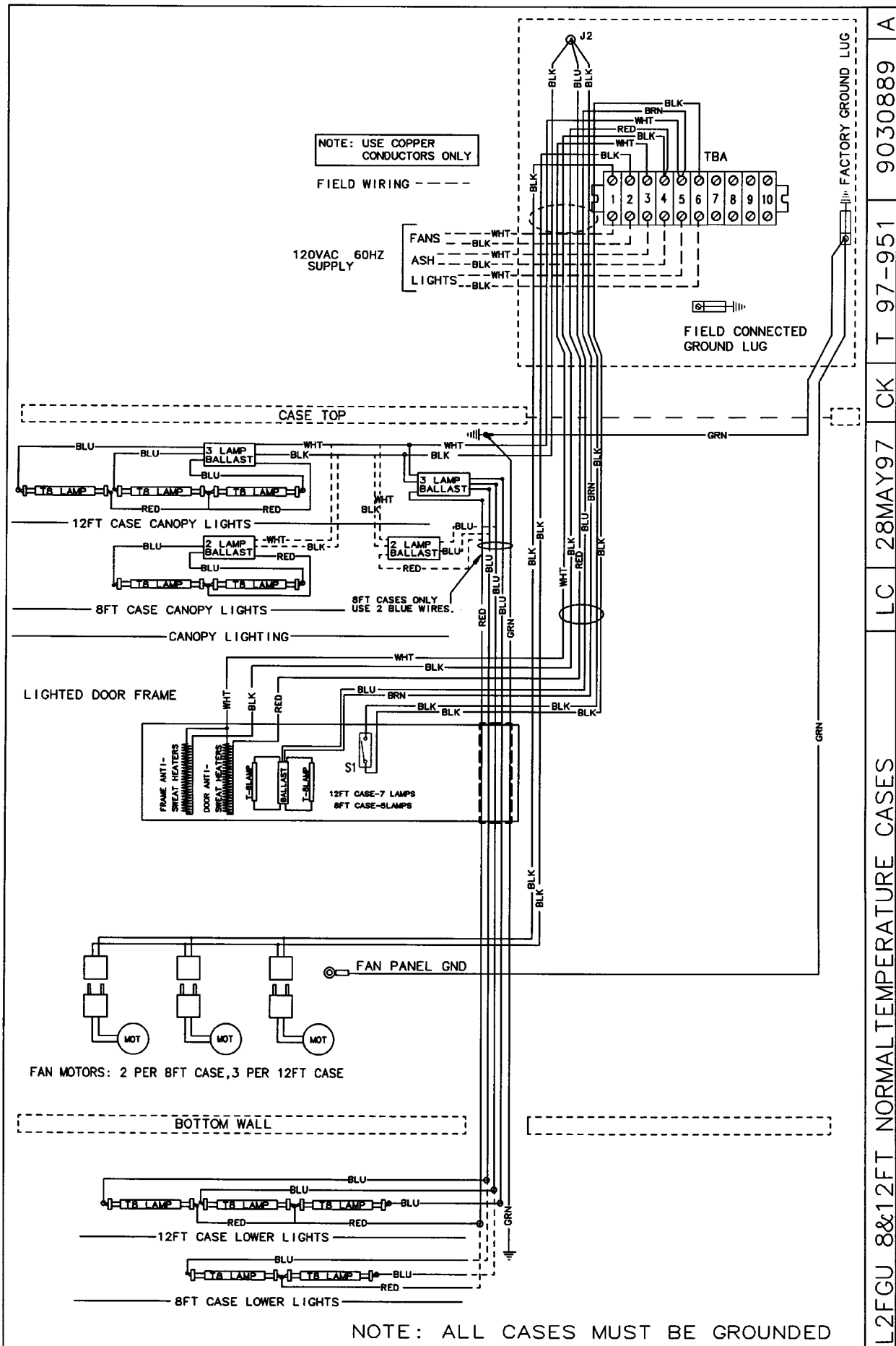

L2FCU 8&12FT NORMAL TEMPERATURE CASES LC 28MAY97 CK T 97-951 9030889 A

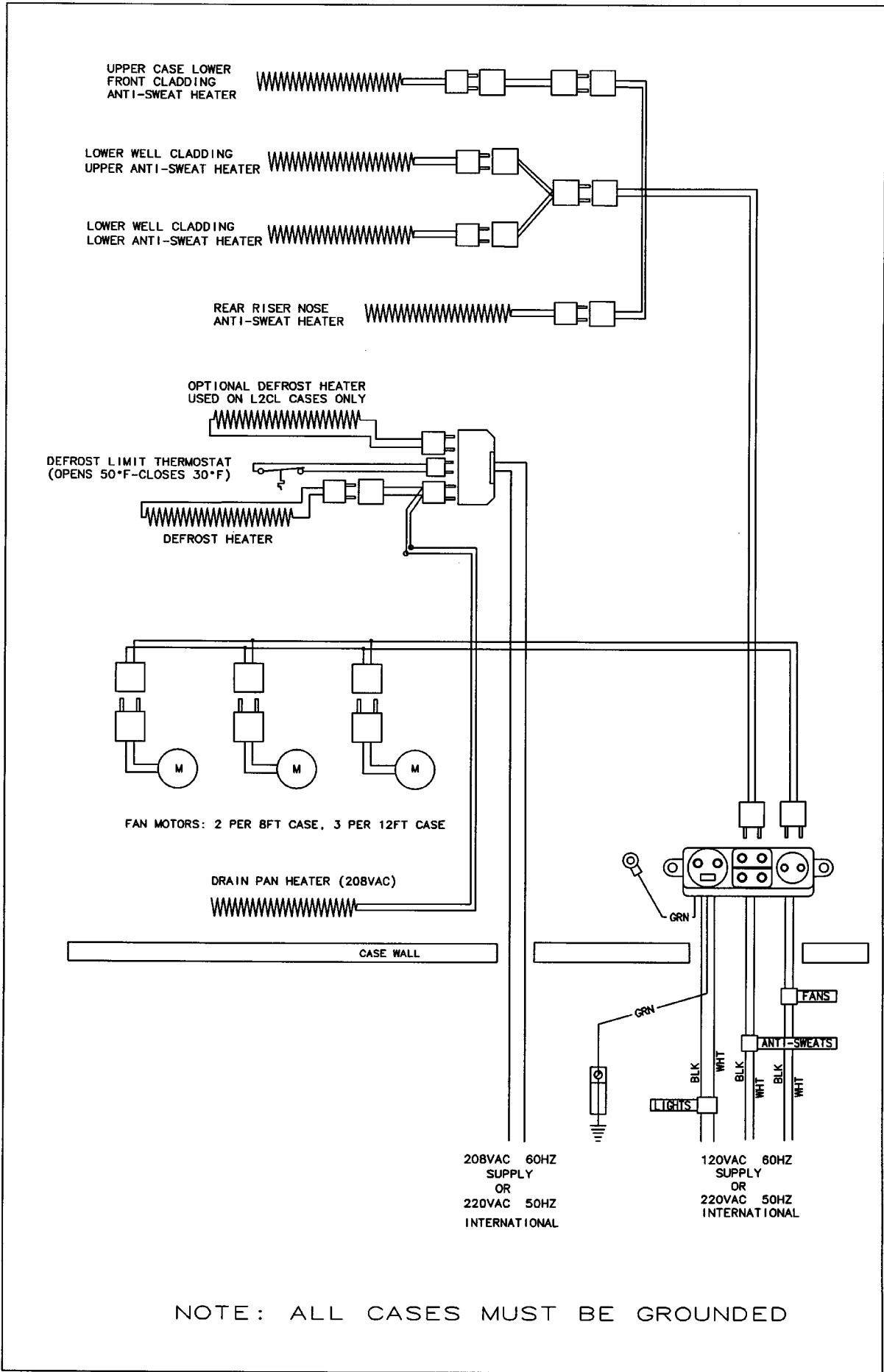

NOTE: ALL CASES MUST BE GROUNDED

L2FL/L2CL 8&12FT CASES, ELECT DEFR LC 27MAY97 CK 96-990-3 9030891 A



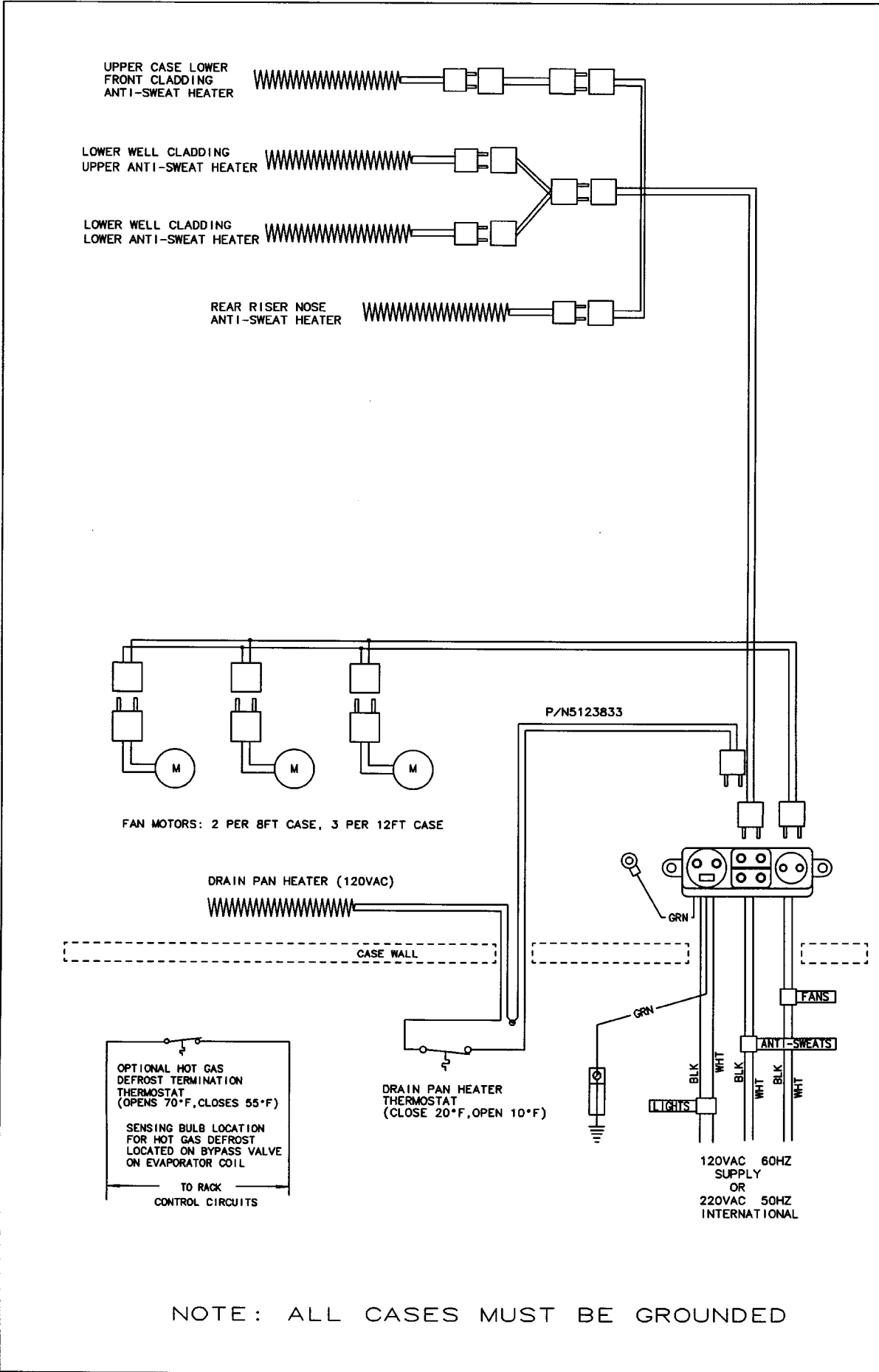

L2FL/L2CL 8&12FT CASES, HOT GAS DEFR 96-990-3 CK 27MAY97 LC 9031369

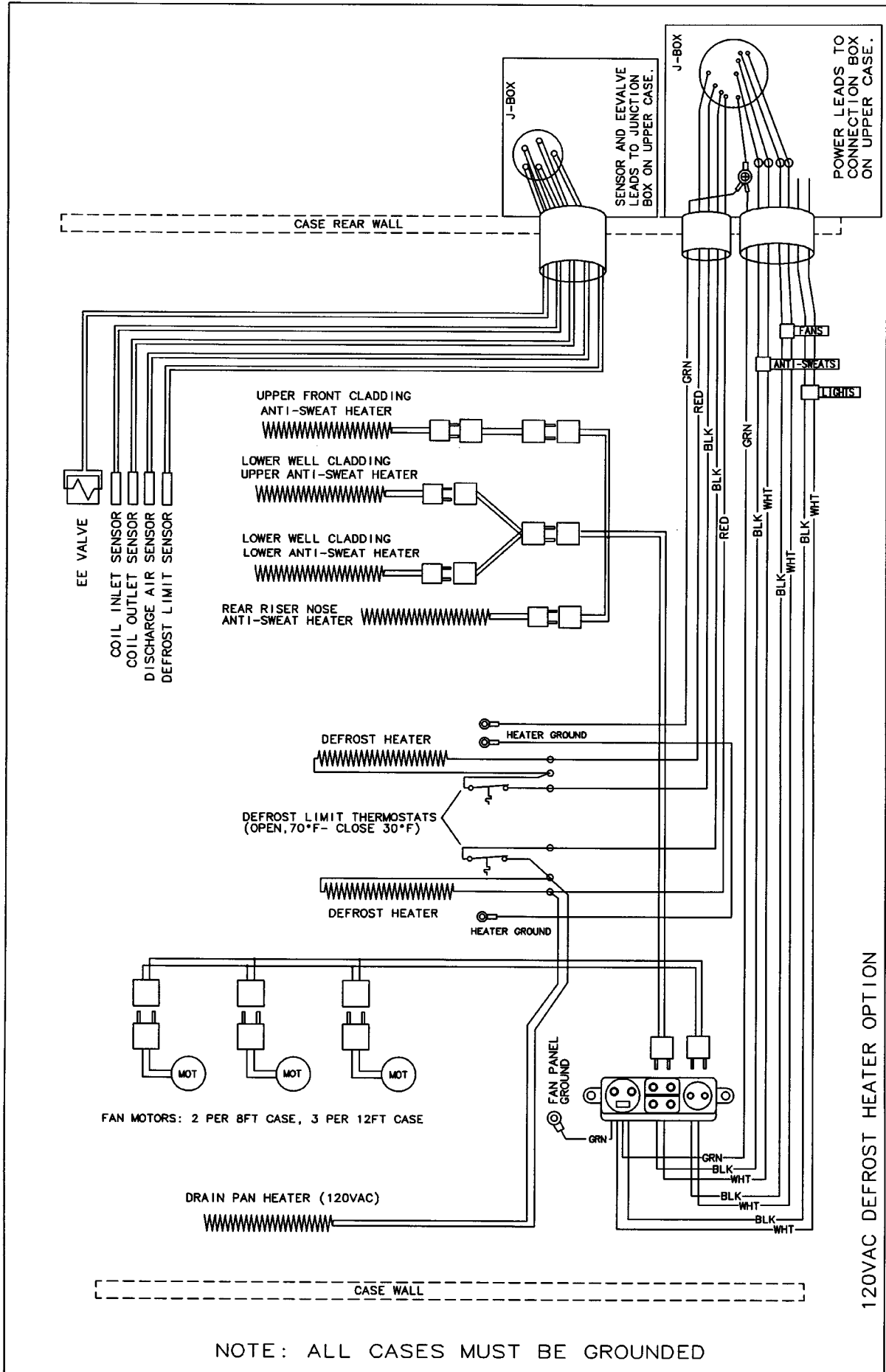

120VAC DEFROST HEATER OPTION  
 L2CL 8&12FT CASES W/ SENSORS AND EE VALVE LC 27MAY97 CK 96-990-3 5217668 B

L2TG Case Lighting Circuits

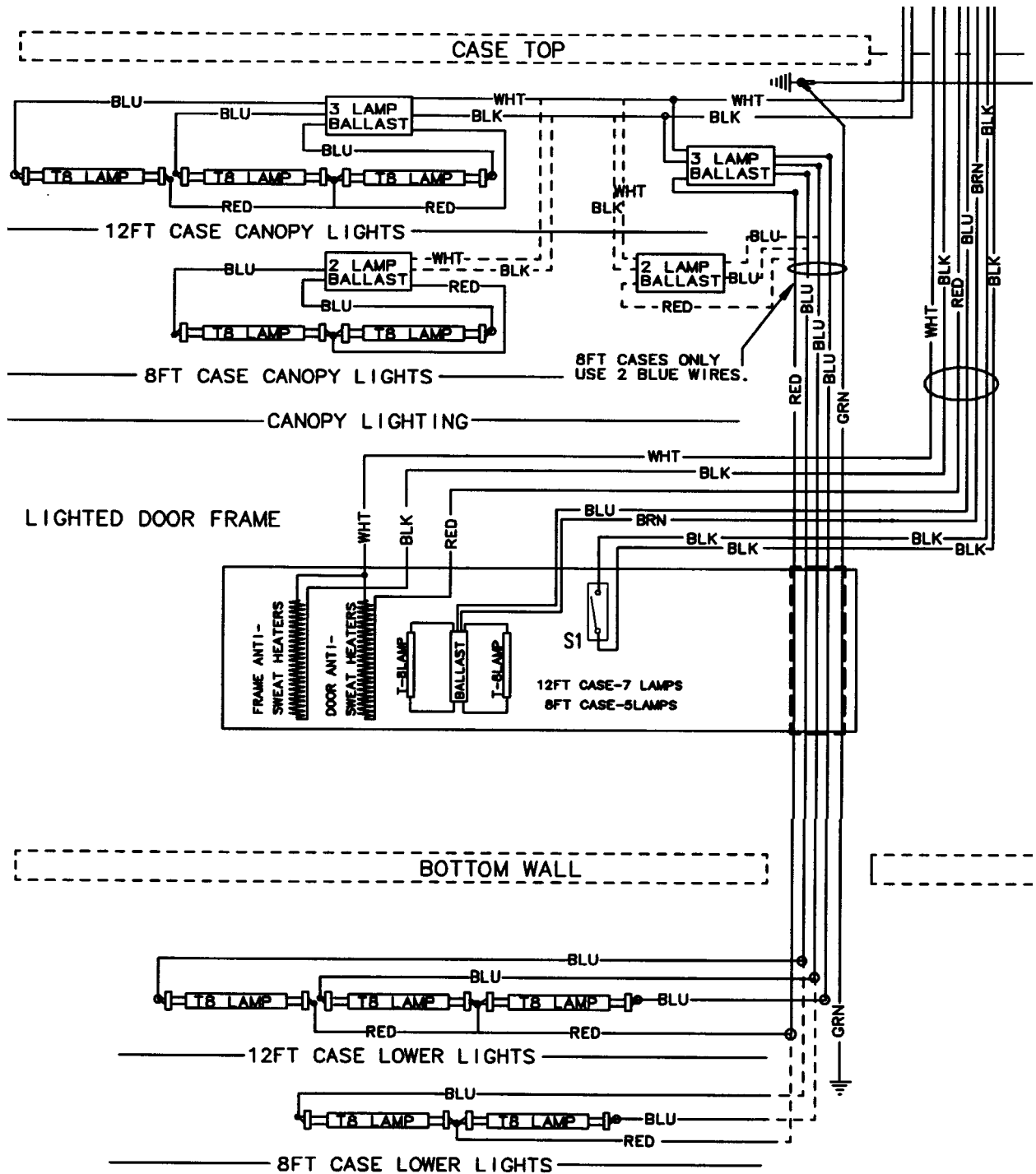

### SERVICE INSTRUCTIONS

See "General I&S Manual" for fan blade and motor replacement, color band and bumper replacement and raceway cover removal instructions.

#### Light Servicing

#### Ballast and Lighting Locations

#### Horizontal T-8 Electronic Lighting

##### 12' CASE

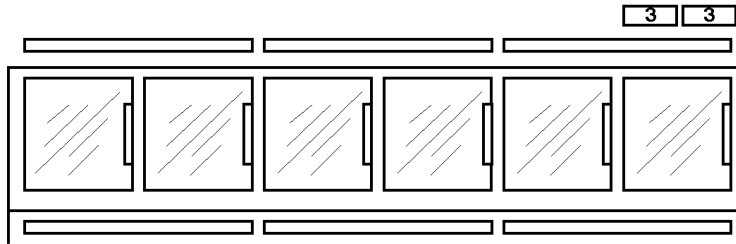

6 - T-8 48" BULBS  
2 - 3-LAMP BALLASTS

##### 8' CASE

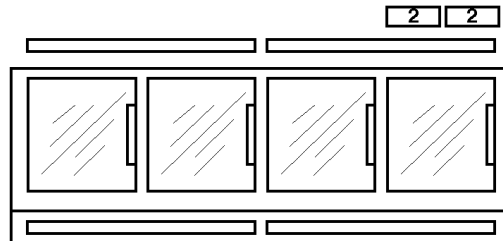

4 - T-8 48" BULBS  
2 - 2-LAMP BALLASTS

#### Vertical T-8 Electronic Lighting

##### 12' CASE

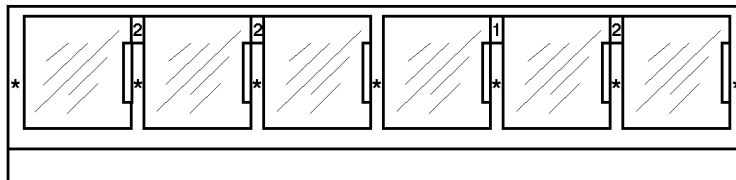

\* - BULB LOCATIONS  
7 - T-8 24" BULBS  
3 - 2-LAMP BALLASTS  
1 - 1-LAMP BALLAST

##### 8' CASE

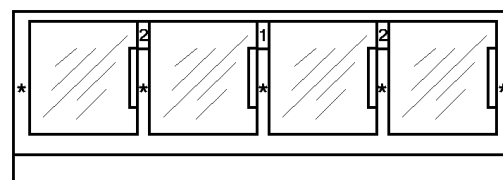

\* - BULB LOCATIONS  
5 - T-8 24" BULBS  
2 - 2-LAMP BALLASTS  
1 - 1-LAMP BALLAST

Lamp Replacement

**CAUTION**

Shut off light switch or disconnect power supply before changing a lamp. Lighting system power and/or ballast surges can burn out adjacent lamps if power is left on.

**NOTE**

See "T-8 Lamp Replacement" in "General I&S Manual" for canopy and/or open well lamp replacement instructions.

T-8 Electronic Vertical Lamp (Prism)

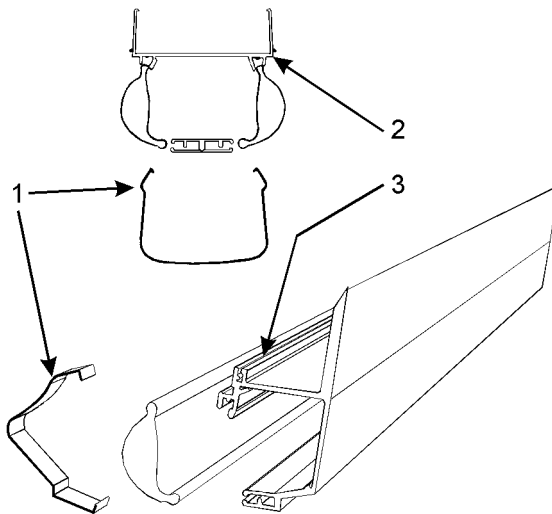

1. Carefully remove two steel clips (1) from mullion (2) and/or light fixture (3). Save clips for reinstallation.

**NOTE**

The light cover does not need to be completely removed to replace the lamp.

2. Separate light cover (4) from groove in light fixture (3) and swing light cover (4) into the case to expose the lamp (5).

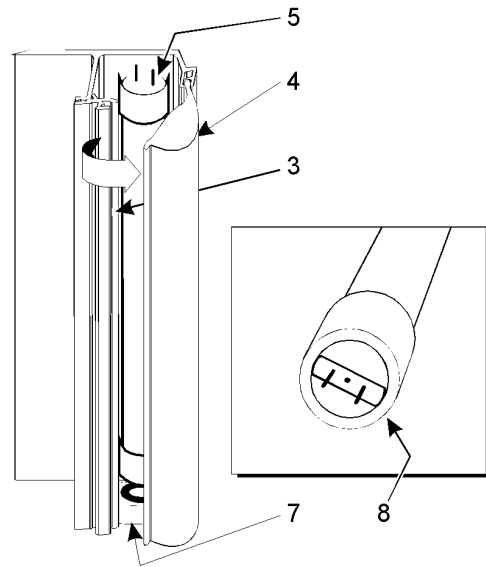

3. Hold lamp (5) with fingers and twist to line up tabs on end of lamp (5) with slots in receptacles (7). Carefully remove lamp (5) from receptacles (7) and case.
4. Remove insulator tubes (8) from each end of lamp (5).

**CAUTION**

Foam end caps and insulator tubes must be properly installed. Improper installation of these components could decrease lamp efficiency and/or product life.

5. Install insulator tubes (8) on ends of new lamp (5).
6. Install new lamp (5) in receptacle slots (7) and carefully turn two clicks.
7. Make sure foam end caps (9) are in place above and below the receptacles (7).
8. Rotate light cover (4) over lamp (5) and snap into groove in light fixture (3).
9. While holding light cover (4) snugly against top of light fixture (3), snap two steel clips (1) into place.
10. Turn on the light switch or reconnect the power to the lights.

## Electronic Ballast Replacement (Prism Lighting)

### **WARNING**

Before replacing a ballast, make sure all power is off to the case. Electrical servicing should always be done by a qualified electrician. Improper servicing could result in product damage and/or personal injury.

### **NOTE**

Refer to T-8 ballast location page and wiring diagrams in this manual for specific model information.

1. Remove door following the door removal instructions in this manual.

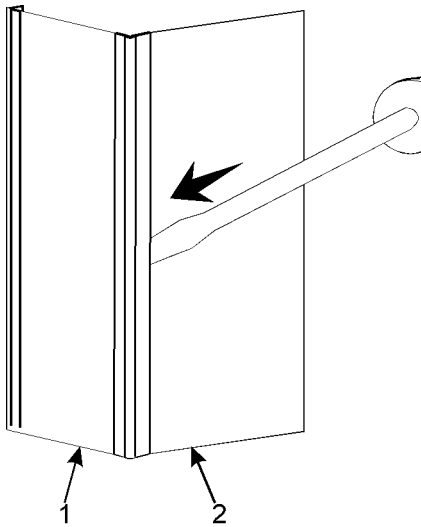

2. Using a flat-headed screwdriver under the back edge of the contact plate retainer (1), gently pull up to unsnap both sides of retainer (1) from mullion (2).
3. Remove contact plate (3) and heat barrier (4) from mullion (2).

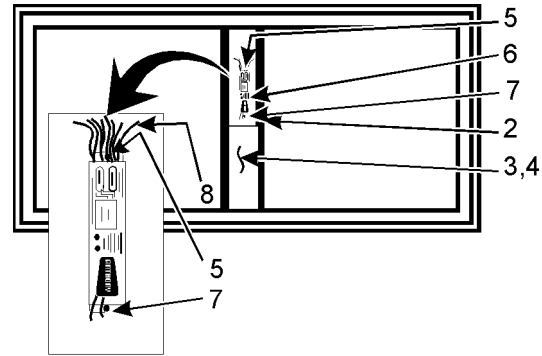

4. Remove screw (5) on top end of ballast (6). Slide ballast (6) up and out of punched tabs (7) in mullion (2).

### **NOTE**

**If wire leads are cut during removal, make sure to leave enough wire to reconnect a new ballast with a wire nut.**

5. Disconnect or cut all wire leads (8) to ballast (6).
6. Insert bottom of new ballast (6) in bottom tabs (7) on mullion (2) and secure with screw (5) in top end of ballast (6).
7. Reconnect wire leads (8) to new ballast (6) following the wiring diagram on the new ballast (6).
8. Position heat barrier (4) in the mullion (3).
9. Position contact plate (3) flat on the mullion (2). While holding contact plate (3), insert retainer (1) into front edge of mullion (3), then snap retainer (1) into back edge of mullion (3). Repeat process to install retainer (1) on opposite side.
10. Replace door following the door installation instructions in this manual.
11. Reconnect power to the case.

(Horizontal Lighting)

**WARNING**

Before replacing a ballast, make sure all power is off to the case. Electrical servicing should always be done by a qualified electrician. Improper servicing could result in product damage and/or personal injury.

**NOTE**

- Refer to ballast & lighting location page and wiring diagrams in this manual for specific model information.
- If wire leads are cut during removal, make sure to leave enough wire to reconnect a new ballast with a wire nut.

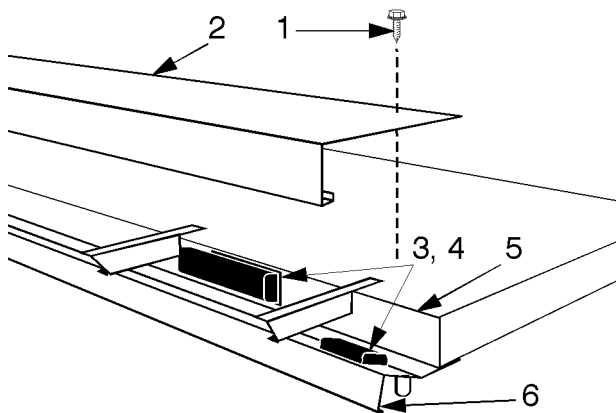

1. Remove the screws (1) and the canopy (2) from the front top of the case.
2. Remove four screws (3) and defective ballast (4) from front of top shelf (5) or top of light channel (6).
3. Disconnect or cut all wire leads to ballast (4).

4. Install new ballast (4) on the top shelf (5) or light channel (6) with four screws (3).
5. Reconnect wire leads to new ballast (4) following the case lighting circuit wiring diagram in this manual.
6. Replace canopy (2) and secure with the screws (1).
7. Reconnect power to the case.

**Upper Case Door Servicing**

**Door Removal**

**CAUTION**

Before removing door, decrease torque tension clockwise to prevent possible damage to the door.

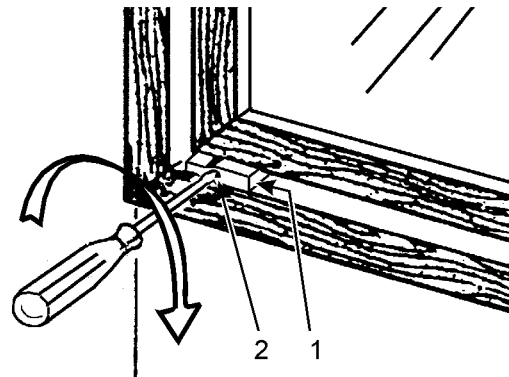

1. Release tension on Torquemaster™ (1) by turning screw (2) clockwise.

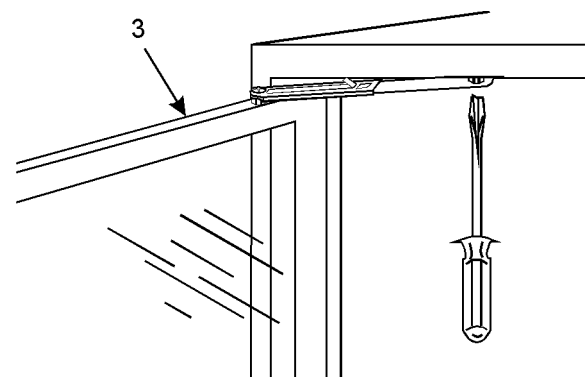

2. Open door (3) and lock into the hold-open position.

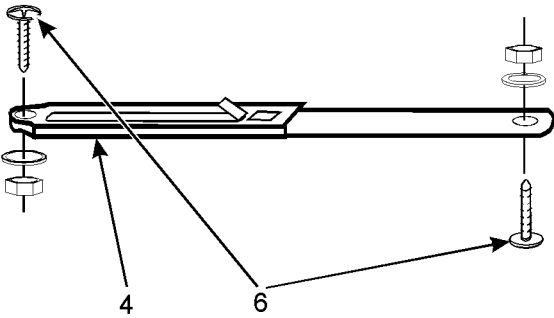

3. Remove two screws (6) and hold-open (4) from frame and door standoffs (7 & 8).

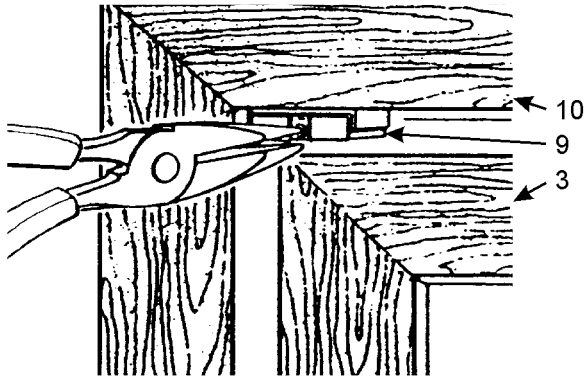

4. Compress and pull hinge pin plug (9) with needle nose pliers to release top of door (3) from frame (10).

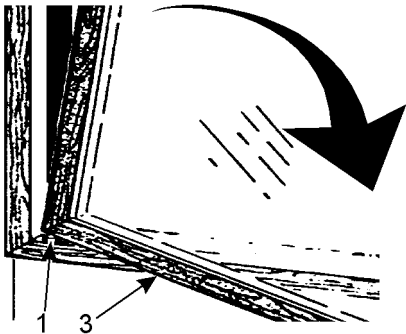

5. Lift door (3) out of Torquemaster™ (1) and remove from case. Place door (3) on its side and lean against a stable surface.

Reversing Door Hardware

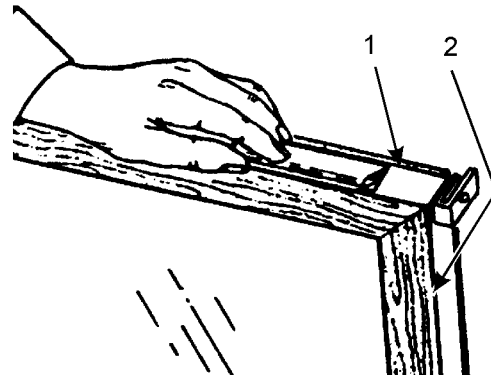

1. Remove hinge pin plug access covers (1) from both side of door (2).

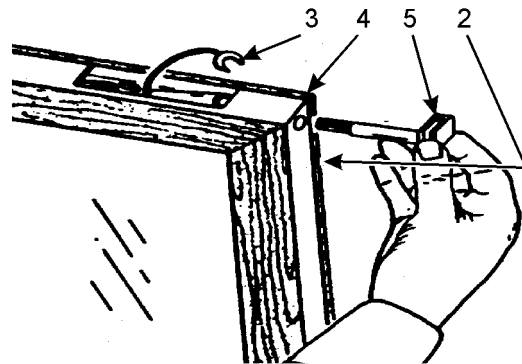

2. Unplug connectors (3) to door and/or glass heater (4) and remove hinge pin plug (5) through top of door (2).
3. Reroute lead wires (6) to new hinge pin location in opposite end of door (2).

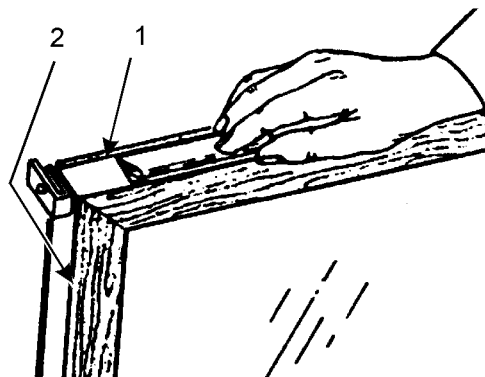

4. Install hinge pin plug (5) and attach connectors (3) to lead wires (6).
5. Carefully replace hinge pin plug access covers (1).



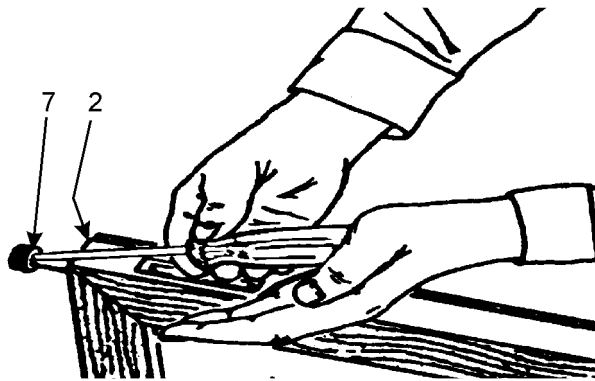

- Slide out torque rod (7) from bottom of door (2) and insert back into opposite end of door (2).

### Reversing Frame Hardware

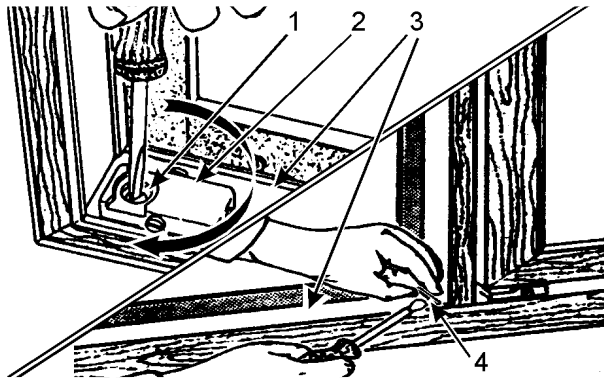

- Turn center screw (1) counter-clockwise and remove Torquemaster™ (2) from bottom door frame (3).
- Pry out cover plate (4) from opposite end of bottom door frame (3).
- Reverse positions and install Torquemaster™ (2) and cover plate (4) in bottom door frame (3).

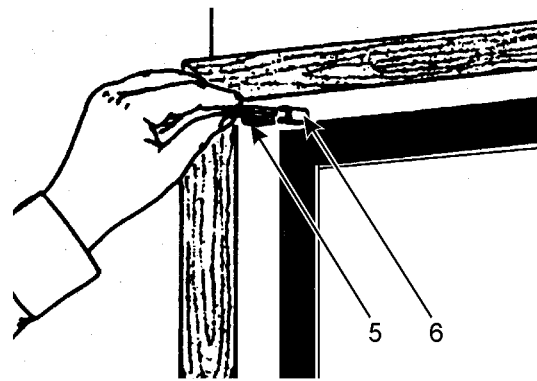

- Insert dummy plug (5) into old top hinge pin receptacle (6).

### Door Handle Replacement

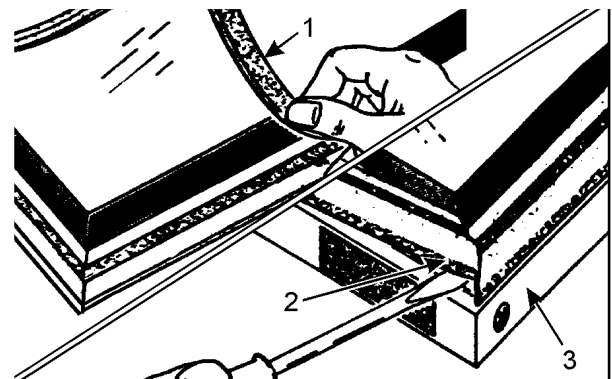

- Starting at a corner, remove the gasket (1) from retainer strip (2) on handle side of the door (3).
- Starting at corner, remove retainer strip (2) from handle side of door (3).

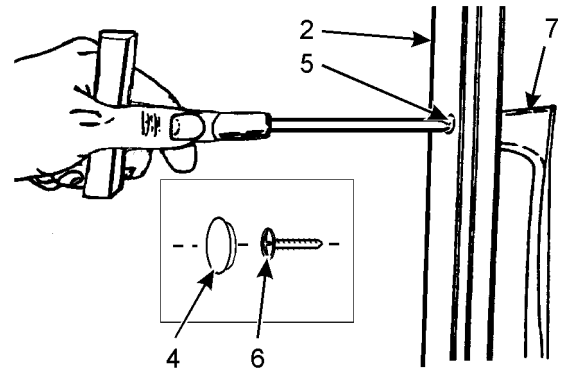

- Remove plastic hole plugs (4) from handle access holes (5).
- Using a 5/32" allen wrench, remove two screws (6) and handle (7) from door (2).
- Install new handle (7) in reverse order.

**Door and Mullion Heater Replacement**

All glass door cases use the same door and mullion heaters. Medium and low temperature cases run different wattages through them. Low temperature cases also use electrically heated door glass. Mullion heaters are located in four different locations. Door frame heater is a full length wire in each door frame. Perimeter heater is a full length wire around the entire case frame. Threshold heater is a additional wire across the lower part of the case frame. Vertical heater has a separate heater and wire in each vertical mullion between the doors.

**Door Heater**

1. Remove door from case following the door removal instruction in this manual.

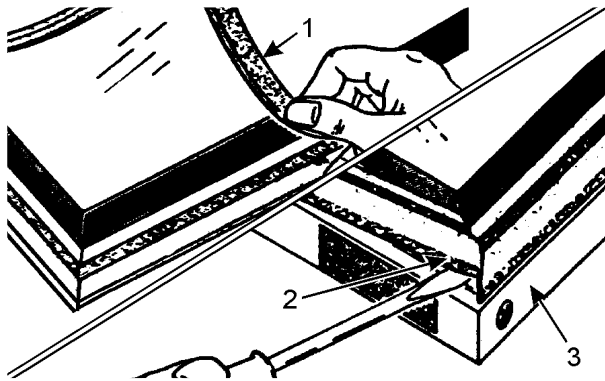

2. Starting at corner, remove gasket (1) from retainer strip (2).
3. Starting at a corner, remove all retainer strips (2) from the door (3).

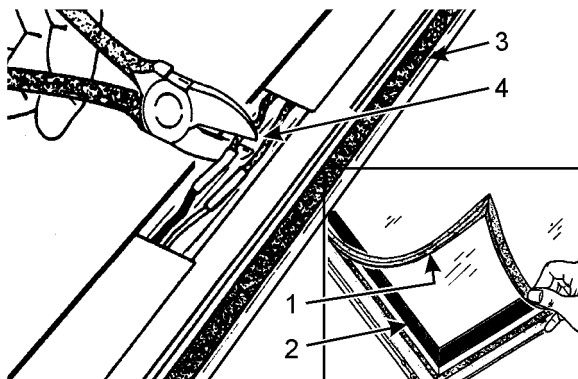

4. Disconnect or cut solid heater lead wire (4) and remove from door (3). Insert and connect new solid lead wire (4) in door (3).

5. Replace retainer strips (2) and gasket (1) on the door (3).
6. Replace door on case following the door installation instructions in this manual.

**Mullion Heater**

1. Remove necessary door(s) following the door removal instructions in this manual.

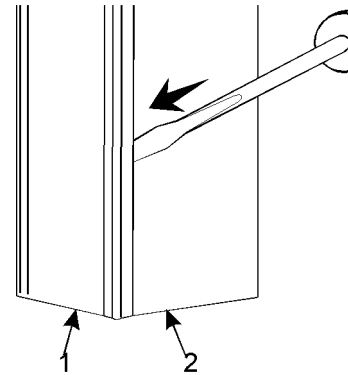

2. Using a screwdriver, remove necessary contact plate retainers (1) and contact plates (2) and heat barriers (3), where applicable, from mullions (4) to expose heater wire(s). Vertical wire requires removal of vertical contact plate and two adjacent top contact plates. Threshold wire requires removal of bottom and end contact plates. Perimeter wire requires removal of all contact plate (top, bottom, end, and center).

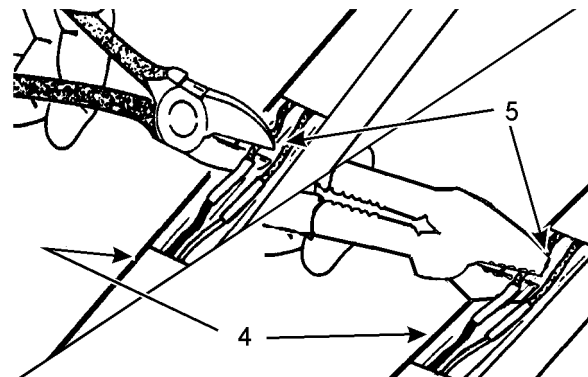

3. Disconnect or cut defective heater wire (5) and remove from mullion (4).
4. Connect and install new heater wire (5) in mullion (4).

5. Replace heat barriers (3), where applicable, and contact plates (2) and contact-plate retainers (1) on mullions (4)
6. Replace door(s) following the door installation instructions in this manual.

**Door Installation**

1. Insert door torque rod (1) on bottom of door (2) into Torquemaster™ (3) at base

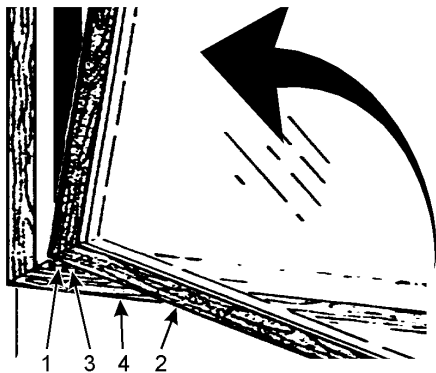

of door frame (4).

2. Insert hinge pin plug (5) on top of door

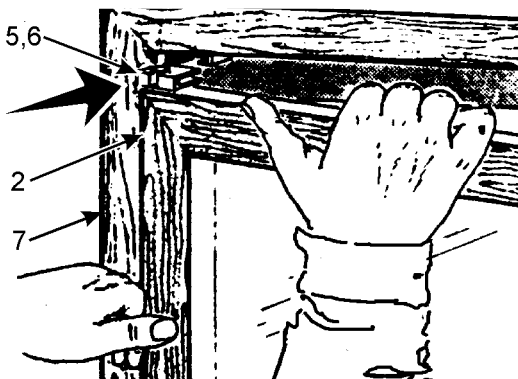

(2) into hinge pin plug receptacle (6) at top of door frame (7). Push in top of door (2) until hinge pin plug (5) snaps into place.

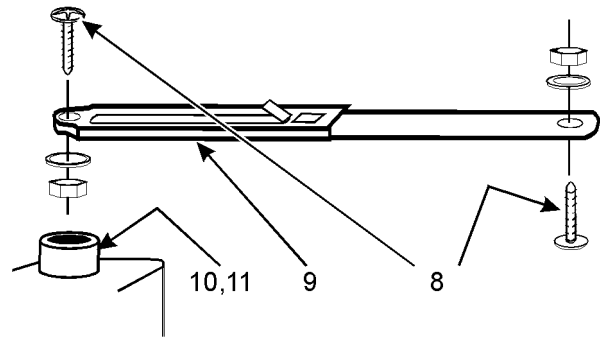

3. Apply loctite to threads of two screws (8).
4. Install hold-open (9) on door and frame standoffs (10 & 11) and secure with two screws (8). **Do not overtighten the screws.**

**NOTE**

- Do not use power tools to adjust the Torquemaster™.
- When Torquemaster™ is properly adjusted, the door will securely close without slamming. Over adjusting close will cause the door to slam during closing.

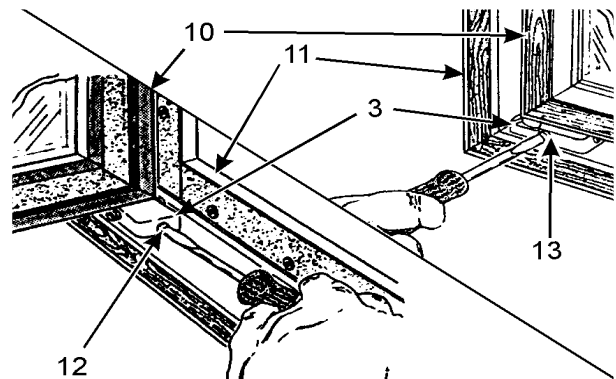

5. Align door (10) in frame (11) by adjusting screw (12) on side of Torquemaster™ (3).
6. Adjust closing force by turning the screw (13) on the front of the Torquemaster™ (3). Turn screw (13) counter-clockwise to increase, or clockwise to decrease the closing force.

## Case Defrost & Dan Pan Heater Replacement

### WARNING

Before replacing defrost or drain pan heater, shut off electrical power to the case to avoid personal injury and/or death.

### Upper Case Electric Defrost Heater

1. Open doors and remove bottom trays from case.

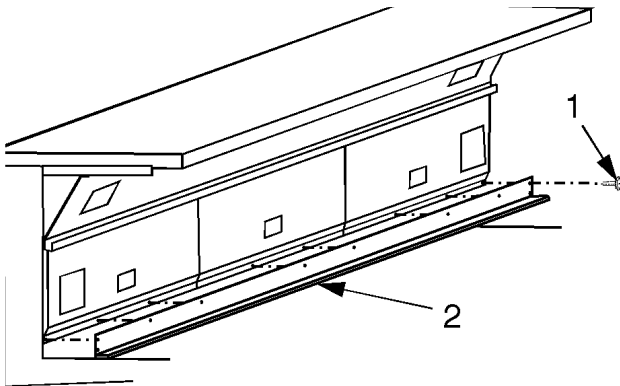

2. Open doors and remove screws (1) and lower back panel (2) from rear of case.

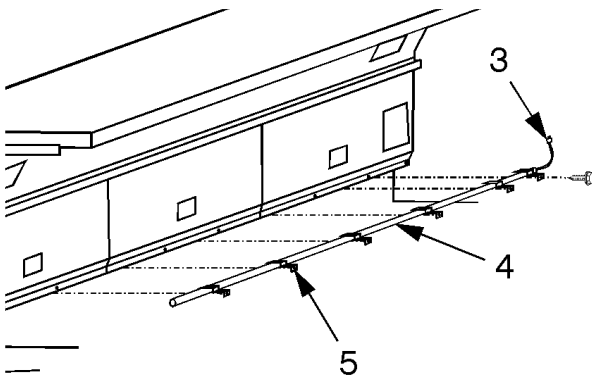

3. Disconnect heater wire (3) from terminal block behind back panel.
4. Remove defective heater (4) from mounting brackets (5).
5. Install new heater (4) in reverse order.
6. Connect heater wire (3) to terminal block behind back panel.
7. Install lower back panel (2) with screws (1) and replace bottom trays in case.
8. Restore electrical power to the case.

### Lower Case Electric Defrost Heater

1. Remove screens and bottom trays from case.

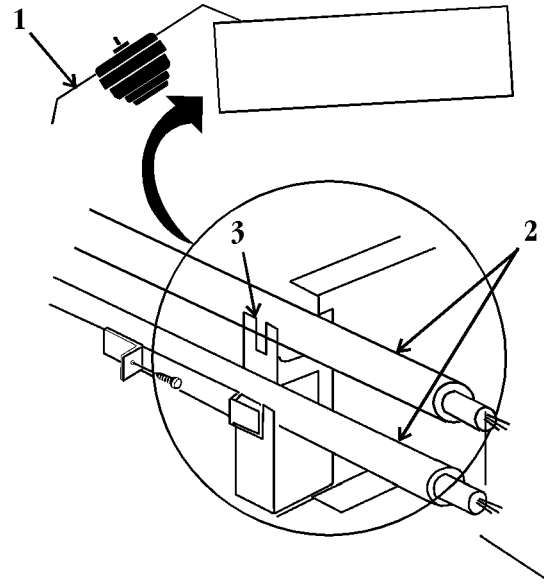

2. Unclip and lift up fan plenum (1).
3. Disconnect defective defrost heater (2) and remove from mounting clips (3) and case.
4. Install new defrost heater (2) in reverse order.
5. Restore electrical power to case.

Lower Case Drain Heater

1. Remove screens and bottom trays from case.

**NOTE**

Note the positioning of the drain heater wires before disconnecting for proper installation of the new heater.

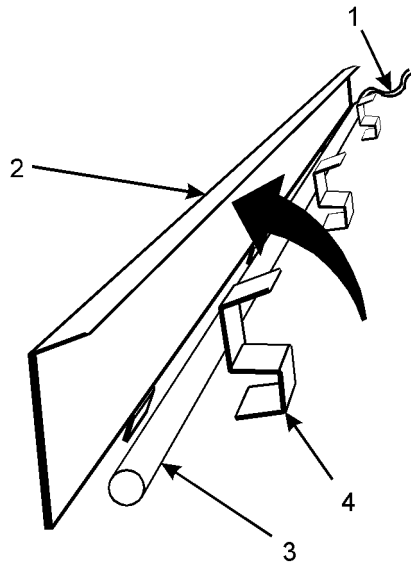

2. Disconnect drain heater wires (1) at the wire nut connections in the bottom of the case.
3. Lift up drain trap heater support (2) and remove defective drain heater (3) from mounting brackets (4).
4. Install new drain heater (3) in mounting brackets (4) and lower drain trap heater support (2).
5. Connect heater wires (1) as removed and secure with wire nuts at connections.
6. Install bottom trays and screens in case.
7. Restore electrical power to the case.

Fan Locations and Access

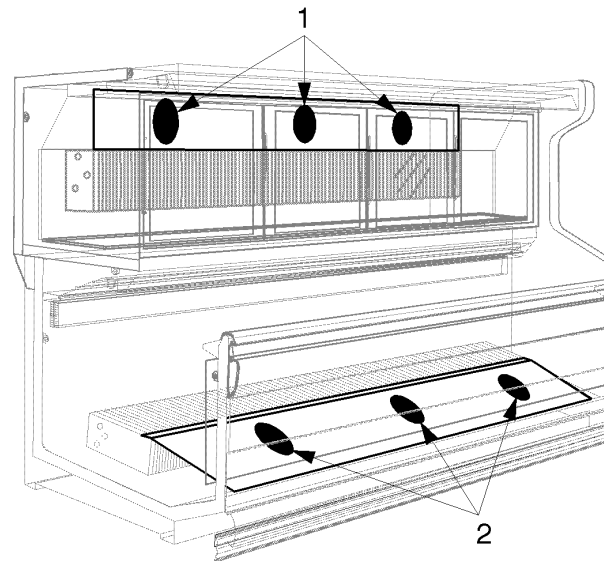

The upper case fans (1) are located behind the slanted upper panel. Remove the upper panel to access the upper case fan panel. The lower case fans (2) are located in the bottom of the lower well. Remove the bottom trays to access the lower case fan panel.

See "General I&S Manual" for fan blade and motor replacement instructions.

Anti-Sweat Replacement

**WARNING**

Shut off or disconnect power supply to case before changing an anti-sweat. Electrical power from wire ends could damage other components and/or cause personal injury or death.

**NOTE**

See "Upper Case Door Servicing" section in this manual for upper case anti-sweat replacement instructions.

### Deflector Panel & Discharge Air Grid Anti-Sweats (L2FL/L2CL)

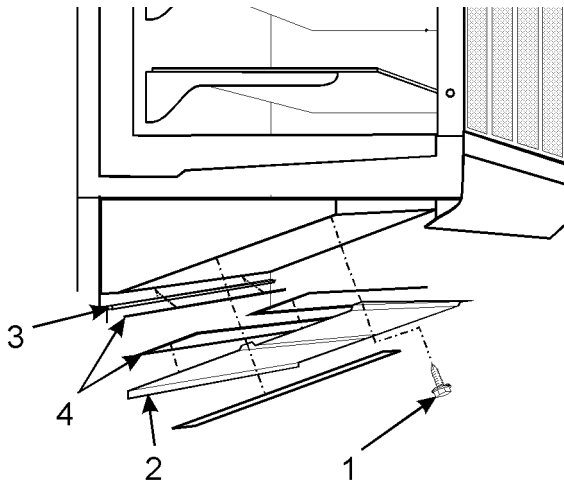

1. Remove screws (1) and slanted deflector panels (2) from area above the lower case discharge air grid (3).
2. Disconnect or cut the defective anti-sweat wire (4) from the case wires. There are two anti-sweat wires on the back of the slanted deflector panels and one anti-sweat wire on top of the discharge air grid support.
3. Remove and replace the aluminum tape and defective anti-sweat wire (4) from slanted deflector panels (2) or top of discharge air grid support assembly (3).
4. Reconnect the anti-sweat wire (4) to case wires and replace the slanted deflector panels (2).

### Upper Front Cladding Anti-Sweat (L2FGU)

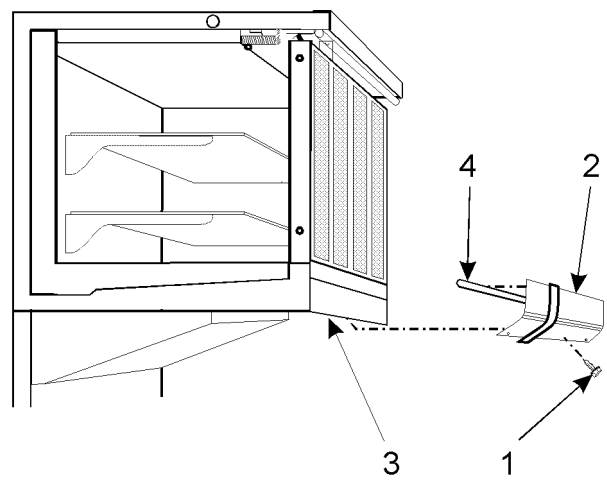

1. Remove screws (1) and upper front cladding (2) from bottom of upper case (3).
2. Disconnect or cut the defective anti-sweat wire (4) from the case wires.
3. Remove and replace the aluminum tape and defective anti-sweat wire (4) from back of upper front cladding (2).
4. Reconnect the anti-sweat wire (4) to case wires and replace the upper front cladding (2) and screws (1).

### Optional Sensor Locations and Access

This case can be equipped with up to eight different sensors, four for the upper case and four for the lower case. The sensors monitor discharge air, coil in, coil out temperatures and defrost termination.

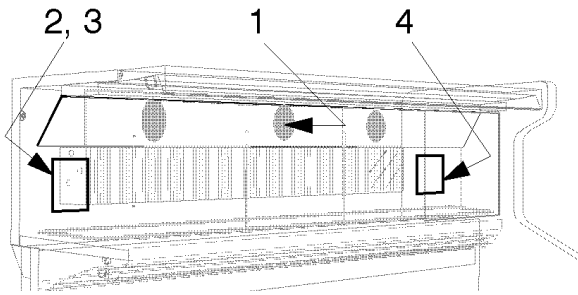

The upper case sensor locations:

1. Discharge air is located on the back wall behind the center fan assembly. It can be accessed by removing the slanted upper panel and the center fan assembly.
2. Coil in is located on the left end of the coil accessed thru the back panel .
3. Coil out is located on the left end of the coil accessed thru the back panel .
4. Defrost termination is on the right end of the coil accessed thru the back panel.

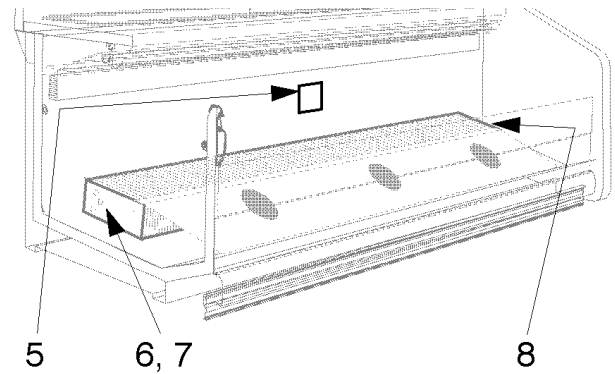

The lower case sensor locations:

5. Discharge air located on back of center access cover.
6. Coil in is located on left end of coil under the lower tray.
7. Coil out is located on left end of coil under the lower tray.
8. Defrost termination is located on the right end of the coil under the lower tray.

## PARTS INFORMATION

### Cladding and Trim Parts List

<u>Item</u>	<u>Description</u>	<u>8' / 4DR</u>	<u>12' / 6DR</u>
1	Bumper End Trim		color per order
2	Upper Front Cladding, Painted	5968090	5968091
3	Bumper Retainer/Hand Rail		color per order
	Screw	9025833 (18)	9025833 (26)
4	Color Band, Painted	9020981	9020982
5	Bumper		color per order
6	Lower Front Cladding, Painted	9025209	9025210
	Cladding Retainer	9300197 (4)	9300197 (4)
	Screw	5183536 (8)	5183536 (8)
7	Raceway Cover		color per order
8	Kickplate		color per order
	Screw	5183536 (6)	5183536 (8)
9	Raceway Cover Retainer	9300600 (4)	9300600 (6)
	Screw	5183536 (4)	5183536 (6)
10	Kickplate Support Assy.	9042341 (3)	9042341 (4)
	Shoulder Screw	9025833 (12)	9025833 (16)
11	Raceway Cover Backer		color per order
12	Raceway Cover End Trim		color per order
13	Raceway	9300218	9300219
	Screw	5183536 (18)	5183536 (18)
	Raceway Support	9041321 (6)	9041321 (8)
	Raceway CVR Support	9041325 (6)	9041325 (8)
	Screw	5183536 (12)	5183536 (16)
14	RH End Close-off, Painted	9030856	9030856
	LH End Close-off, Painted	9030855	9030855
	Screw	5048626 (4)	5048626 (4)
15	Bumper Backer		color per order
16	Horizontal Joint Trim	5127503	5127503
17	Color Band Backer, Painted	9025982	9025982
18	Hand Rail Backer	9025316	9025316
19	Front Duct Joint Trim	5203017	5203017
	Screw	5105037 (4)	5105037 (4)
20	Upper Front Cladding Joint Trim, Painted	5217592	5217592
	Screw	5205439 (4)	5205439 (4)



<u>Item</u>	<u>Description</u>	<u>8' / 4DR</u>	<u>12' / 6DR</u>
21	Rear Riser Joint Trim	5945062	5945062
	Rivet	5104702 (6)	5104702 (6)
22	Door Joint Trim	5967778	5967778
	Binding Screw	5222637 (2)	5222637 (2)
23	Light Channel Joint Trim	5217606	5217606
24	Screw	5205439 (8)	5205439 (8)
25	Canopy Joint Trim, Painted	5646488	5646488
26	Hood Canopy, Painted	5967715	5967716
27	Screw	5619204 (8)	5619204 (12)

