

SPECIFICATION SHEET

LPFMT REFRIGERATED COMBINATION MERCHANDISERS WITH GRAVITY / SERPENTINE COIL TOP DOME

Refrigeration Data:

MODEL	CASE LENGTH	CASE USAGE	CASE CAPACITY (BTUH / FT)		EVAPORATOR (°F)	UNIT SIZING (°F)	DISCHARGE AIR			AVG. REF. CHARGE (LBS/FT)
			PARALLEL	CONVENTIONAL			DOME (°F)	SELF SERVE (°F)	VELOCITY (FPM)	
LPFMT	6' / 8' / 12'	MED TEMP	909*	1,023*	+15**	+13	+29	+23	117***	N/A

* Capacity data listed for cases with 1 row of T-8 Dome Lights, 1 row of T-8 Canopy Lights and 2 rows of optional lighted shelves.

If case has unlighted shelves, **DEDUCT** 23 BTUH/FT per row of unlighted shelves on the case.

** Evaporator temperature is based on the saturated pressure leaving the case.

*** Air velocity measured 1 hour after defrost at the back edge of the top shelf.

FOR SPECIFIC COMPRESSOR SIZING INFORMATION, REFER TO TYLER APPLICATIONS FOR RACK SYSTEM COMPRESSORS AND/OR THE COMPRESSOR MANUFACTURERS FOR SINGLE COMPRESSORS. FOR LINE SIZING INFORMATION, REFER TO THE MISCELLANEOUS SECTION "BUFF" IN THE TYLER SPECIFICATION GUIDE.

Electrical Data:

Fans (120 Volt)

MODEL	CASE LENGTH	FANS / CASE	TOTAL STANDARD FANS		TOTAL ECM FANS	
			AMPS	WATTS	AMPS	WATTS
LPFMT	6'	2	1.06	96.0	0.44	22.0
LPFMT	8'	2	1.06	96.0	0.44	22.0
LPFMT	12'	3	1.59	144.0	0.66	33.0

T8 Lighting with Electronic Ballasts (120 Volt)

MODEL	CASE LENGTH	DOME LIGHTS 1-ROW		CANOPY LIGHTS 1-ROW		SHELF LIGHTS - (PER ROW)				MAXIMUM LIGHTING (4 ROWS)*	
		AMPS	WATTS	AMPS	WATTS	AMPS - (ROWS OF SHELVES)		WATTS - (ROWS OF SHELVES)		AMPS	WATTS
						1	2	1	2		
LPFMT	6'	0.40	48.0	0.40	48.0	0.60	0.80	72.0	96.0	1.60	192.0
LPFMT	8'	0.50	60.0	0.50	60.0	0.70	1.00	84.0	120.0	2.00	240.0
LPFMT	12'	0.70	84.0	0.70	84.0	1.05	1.50	126.0	180.0	2.90	348.0

* For cases with 1 row of dome lights, 1 row of canopy lights and 2 rows of shelf lights.

Defrost Data:

DEFROST TYPE	DEFROSTS PER DAY	DURATION TIME (MIN)	TERMINATION TEMP. (°F)	EPR SETTINGS *		DEFROST WATER (LB/FT/DAY)
				R22 (PSIG)	R404A (PSIG)	
TIME OFF	4	40	N/A	38	50	N/A

* Set EPR to give this pressure at the case.

CASE-TO-CASE SUCTION LINE SUB-FEED BRANCH LINE SIZING													
MODEL	6'	8'	12'	16'	20'	24'	28'	32'	36'	40'	44'	48'	52'
LPFMT (R22)	1/2"	5/8"	5/8"	7/8"	7/8"	7/8"	7/8"	1 1/8"	1 1/8"	1 1/8"	1 1/8"	1 1/8"	1 1/8"

The actual temperature control for the dome section should be set by the thermostat. LPFMT meat settings for the dome section of this case = CUT IN @ 29°F and CUT OUT @ 20°F. Fish ice bed settings for the dome section = CUT IN @ 34°F and CUT OUT @ 32°F.

NOTE: This case comes with a toggle switch that enables the dome section to be isolated from the lower section.

UL SANITATION approved in accordance with ANSI/NSF - 7.

CASE BTUH REQUIREMENTS are calculated to produce approximately the indicated performance with absolute maximum operating ambient limits of **75°F & 55RH**.

The information contained herein is based on technical analysis and/or tests performed in a controlled lab environment that are consistent with industry practices, and is intended as a reference for system sizing and configuration purposes only and for use by persons having technical skill at their own discretion and risk. Conditions of use are outside of Tyler's control and we do not assume and hereby disclaim any liability for results obtained or damages incurred through application of or reliance on the data presented, including but not limited to specific energy consumption with any particular model or installed application. SPECIFICATIONS ARE SUBJECT TO CHANGE WITHOUT NOTICE.

LPFMT CROSS SECTION

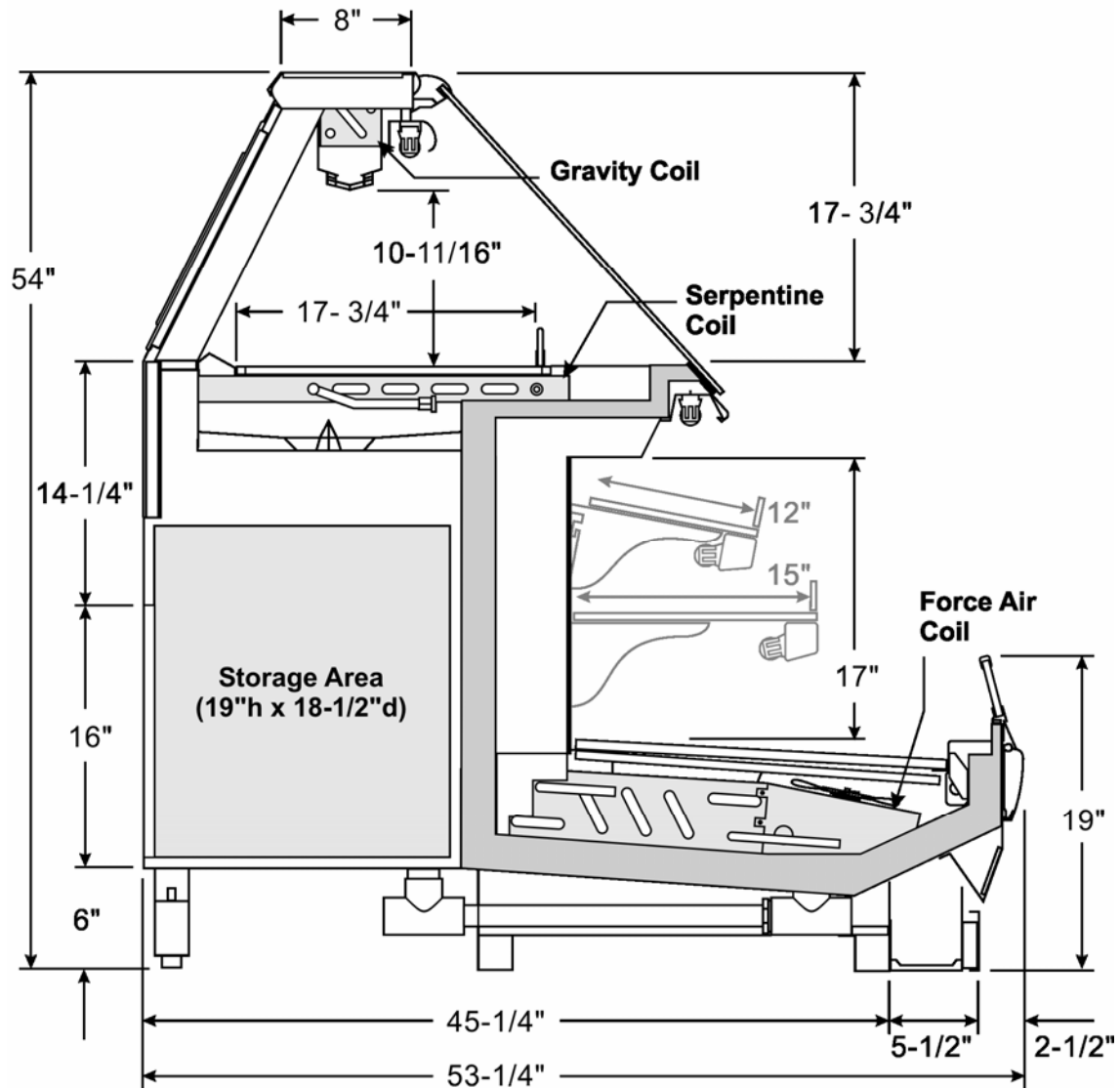

FLOOR PLAN

