

N1P or N1PHP vertical single-deck bulk produce merchandisers have a standard 30" mirror that creates a "waterfall" look to enhance product presentations. The high-profile vertical design provides the focus of single-deck merchandising while having the ability to line up with other vertical multi-decks. An extensive offering of accessories add merchandising flexibility.

**High Performance TC Coil™**

High Performance (HP) Merchandisers feature our patented TC Coil™ design, which represents a major technology breakthrough for the commercial refrigeration industry. Developed jointly by Carrier Corporation and Tyler, the TC Coil™ enables HP merchandisers to operate more efficiently, providing energy savings that allow faster payback periods for food retailers.

**Note:** For more information about Tyler high performance display merchandisers featuring TC Coil™, go to the Technologies section of this catalog on page 8.

**Features & Benefits**

- Energy-efficient copper tube and aluminum fin coils.
- One row of energy efficient T8 canopy lights with electronic ballasts provide appealing product illumination. Hinged light channel allows easy access to ballasts.
- Adjustable white powder-coated display screens and a 30" mirror enhance product presentation.
- Solid steel base adds strength and durability.
- Easily removable front and rear ducts enhance ease of sanitation.
- Fan assembly design allows access to coil and drain pan.
- Off-cycle defrost.

**Options**

- ECM fan motors for additional energy savings.
- A second row of T8 canopy lights provide greater product illumination.
- Step screens, fences, bag holders, water spray hoses, and scale hangers.

Specifications are subject to engineering changes without notice.

Model	Case Length	Description	Capacity in Cubic Feet*
N1P	8' • 12'	Vertical Single-Deck Bulk Produce, standard coil	15.6 • 23.5
N1PHP	8' • 12'	Vertical Single-Deck Bulk Produce, TC Coil	15.6 • 23.5

\* Cubic capacity is based on case with no shelves and a 30" mirror.

**Optional Accessories**

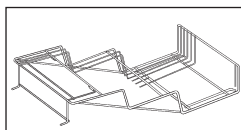

Step screens provide additional merchandising and display flexibility.



This spray hose assembly allows manual misting of bulk produce that keeps products looking fresh.



IN ACCORDANCE WITH NSF  
SANITATION PROCEDURES



N1P  
N1PHP

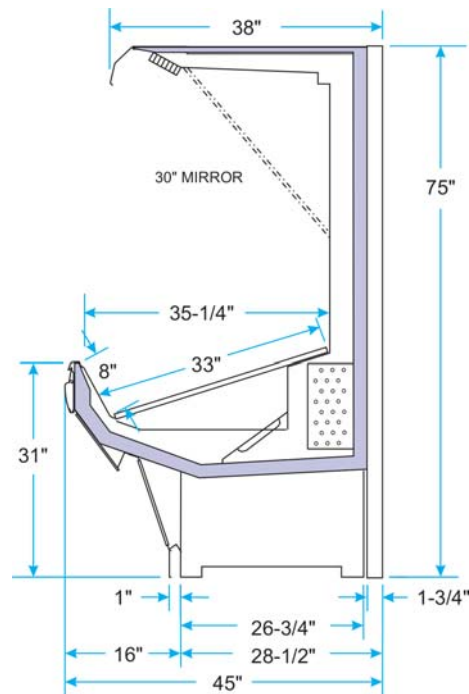

Allow a 3" SPACE between the back of this case and the store wall, other cases, or coolers to minimize possible condensation problems. FORCED VENTILATION may be necessary in some situations.

Add 1-1/2" for Standard Patch End

