

SPECIFICATION SHEET

• N2MHP HIGH PERFORMANCE MED TEMP MEAT/DELI/CRITICAL TEMP PRODUCE WEDGE MERCHANDISER •

Refrigeration Data:

MODEL	CASE LENGTH	CASE USAGE	CAPACITY (BTUH / CASE)		EVAPORATOR (°F)	UNIT SIZING (°F)	DISCHARGE AIR		AVG. REF. CHARGE (LBS/CASE)
			PARALLEL	CONVENTIONAL			TEMPERATURE (°F)	VELOCITY (FPM)	
N2MHP45OSNL	50"	MED TEMP	2,204*	2,463*	+24**	+22	+31	241***	1.90
N2MHP45ISNL	44"	MED TEMP	1,342*	1,503*	+24**	+22	+31	154***	1.06

* Capacity data listed for cases with 1 row of T-8 canopy lights, optional T-8 shelf lighting and optional T-8 nose light. For sizing all refrigeration equipment other than TYLER, use conventional BTUH values.

** Evaporator temperature is based on the saturated pressure leaving the case.

*** Air velocity measured 1 hour after defrost at the top discharge air duct using an ALNOR JR. velometer with a scoop.

FOR SPECIFIC COMPRESSOR SIZING INFORMATION, REFER TO TYLER APPLICATIONS FOR RACK SYSTEM COMPRESSORS AND/OR THE COMPRESSOR MANUFACTURERS FOR SINGLE COMPRESSORS. FOR LINE SIZING INFORMATION, REFER TO THE MISCELLANEOUS SECTION "BUFF" IN THE TYLER SPECIFICATION GUIDE.

Electrical Data:

Fans and Heaters (120 Volt)

MODEL	CASE LENGTH	FANS / CASE	TOTAL STANDARD FANS		TOTAL ECM FANS		TOTAL ANTI-SWEATS	
			AMPS	WATTS	AMPS	WATTS	AMPS	WATTS
N2MHP45OSNL	50"	1	0.80	71.0	0.53	22.0	0.04	5.2
N2MHP45ISNL	44"	1	0.53	48.0	0.32	17.0	0.04	5.2

T-8 Lighting with Electronic Ballasts (120 Volt)

MODEL	CASE LENGTH	CANOPY LIGHTS* --- PER ROW				SHELF LIGHTS - PER ROW				NOSE LIGHT		MAXIMUM LIGHTING (4 ROWS)	
		AMPS		WATTS		AMPS		WATTS		AMPS	WATTS	AMPS	WATTS
		1	2	1	2	1	2	1	2				
N2MHP45OSNL	50"	0.35	N/A	36.0	N/A	0.20	0.30	24.0	48.0	0.50	72.0	1.15	156.0
N2MHP45ISNL	44"	0.30	N/A	48.0	N/A	0.20	0.30	24.0	48.0	0.18	18.0	0.78	114.0

* Standard lighting for this case is 1 row of canopy lights.

Defrost Data:

DEFROST TYPE*	DEFROSTS PER DAY	DURATION TIME (MIN)	ELEK. THERMOSTAT / AIR SENSOR SETTINGS			EPR SETTINGS ***		CONVENTIONAL COMPRESSOR SETTINGS ****				DEFROST WATER (LB / DAY)
			USAGE	CUT IN	CUT OUT	R22 (PSIG)	R404A (PSIG)	R22 (PSIG) CUT-IN CUT-OUT		R22 (PSIG) CUT-IN CUT-OUT		
TIME OFF - N2MHP45OSNL	6	26**	MED TEMP	31°F	29°F	48	61	46	35	59	47	10.8
TIME OFF - N2MHP45ISNL	6	26**	MED TEMP	31F	29°F	48	61	46	35	59	47	5.4

* All high performance cases use OFF CYCLE defrost.

** NOTE: 26 minutes is for EPR with suction stop for defrost isolation. Defrost times increases by eight minutes (34 min. total) when defrost isolation is by pump down.

*** If EPR is utilized, use the settings shown in the chart. ADD 0.5# to EPR setting for each 1000 foot rise in elevation.

**** Required setup for a conventional unit uses an electronic thermostat to assure accurate temperature control.

CASE CIRCUITS: This case requires a 120V circuit for fans, lights and anti-sweat heaters.

UL SANITATION approved in accordance with ANSI/NSF – 7.

CASE BTUH REQUIREMENTS are calculated to produce approximately the indicated entering-air temperature with absolute maximum operating ambient limits of **75°F & 55RH**.

The information contained herein is based on technical analysis and/or tests performed in a controlled lab environment that are consistent with industry practices, and is intended as a reference for system sizing and configuration purposes only and for use by persons having technical skill at their own discretion and risk. Conditions of use are outside of Tyler's control and we do not assume and hereby disclaim any liability for results obtained or damages incurred through application of or reliance on the data presented, including but not limited to specific energy consumption with any particular model or installed application. SPECIFICATIONS ARE SUBJECT TO CHANGE WITHOUT NOTICE.

N2MHP MEAT WEDGE CROSS SECTIONS

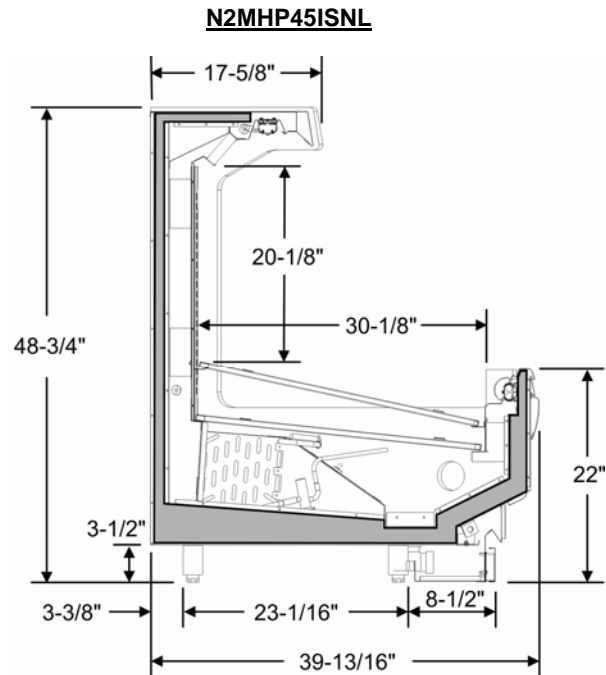
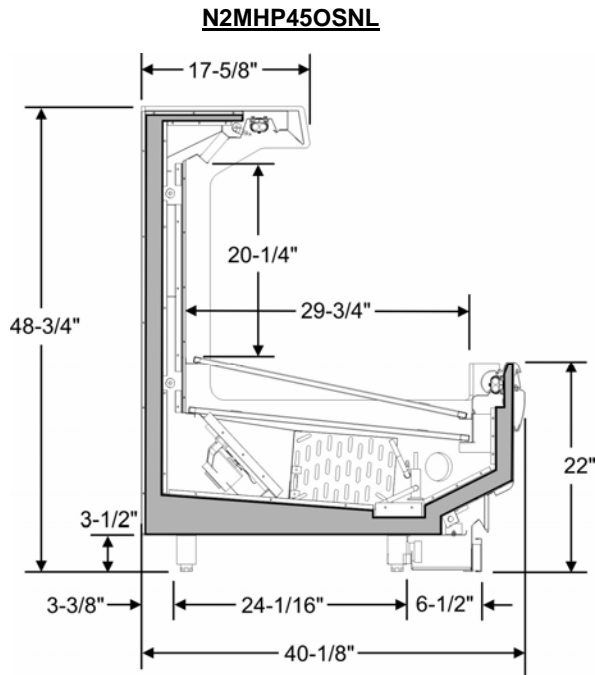

N2MHP MEAT WEDGE FLOOR PLANS

