

N5DSC



Model N5DSC4 shown



The N5DSC is a narrow multi-deck merchandiser with a self-contained refrigeration unit on-board, allowing the unit to be placed anywhere in the store. The narrow depth footprint is designed to fit where space is at a premium.

Features & Benefits

- ♦ Energy-efficient copper tube and aluminum fin coils.
- ♦ Double row of energy-efficient T8 canopy lights.
- ♦ Hinged light channel allows easy access to ballasts.
- ♦ Solid steel base adds strength and durability.
- ♦ Easily removable interior components for quicker cleaning.
- ♦ Fan assembly design allows access to coil and drain pan.
- ♦ Off-cycle defrost.

Options

- ♦ ECM fan motors for additional energy savings.
- ♦ Energy-efficient T8 shelf lighting with remote ballasts for greater product illumination.
- ♦ 20" deep lighted or unlighted shelves.
- ♦ 3 or 6 position shelf brackets for varied shelf display angles.
- ♦ 4' and 6' self-contained models with built-in condensate evaporators.

Specifications are subject to engineering changes without notice.

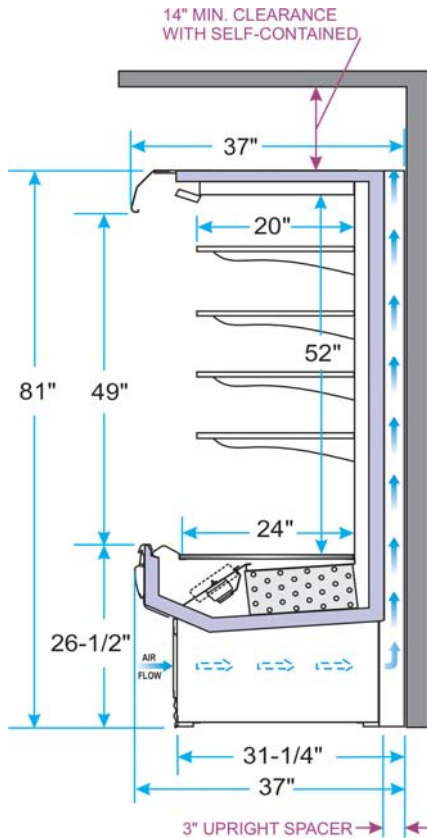

Model	Case Length	Description	Capacity in Cubic Feet*
N5DSC	4' • 6'	Self-Cont., Narrow Multi-Deck, standard coil	27.9 • 41.8

* Cubic capacity is based on four rows of 20" shelves.

3" Upright Spacers assure proper spacing between the back of this case and the store wall, other cases or coolers to minimize possible condensation problems. FORCED VENTILATION may be necessary in some situations.

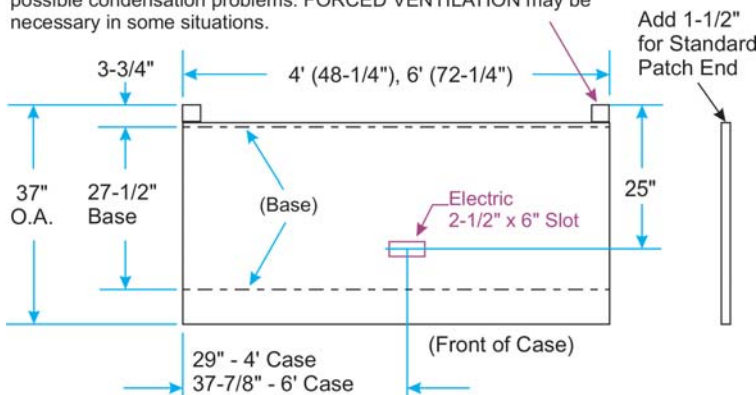

Optional Accessories



Patch ends with glass inserts promote all-around product visibility and illumination.