

N5P



N5P multi-deck bulk produce merchandisers have an extended vertical height that provides options for multiple levels of presentation possibilities in the merchandising of bulk and cut fruits and vegetables.

Features & Benefits

- ♦ Energy-efficient copper tube and aluminum fin coils.
- ♦ Three rows of energy efficient T8 canopy lights with electronic ballasts provide appealing product illumination. Hinged light channel allows easy access to ballasts.
- ♦ Extended height enhances mass merchandising qualities.
- ♦ Solid steel base adds strength and durability.
- ♦ Easily removable interior components enhance ease of sanitation.
- ♦ Fan assembly design allows access to coil and drain pan.
- ♦ Off-cycle defrost.

Options

- ♦ ECM fan motors for additional energy savings.
- ♦ Energy-efficient T8 shelf lighting with remote electronic ballasts provide greater product illumination.
- ♦ 16", 23" or 30" mirrors enhance product presentation.
- ♦ Multiple-depth shelving alternatives.
- ♦ 3 or 6 position shelf brackets for varied shelf display angles.
- ♦ Step screens, fences, bag holders, water spray hoses, and scale hangers.

Specifications are subject to engineering changes without notice.

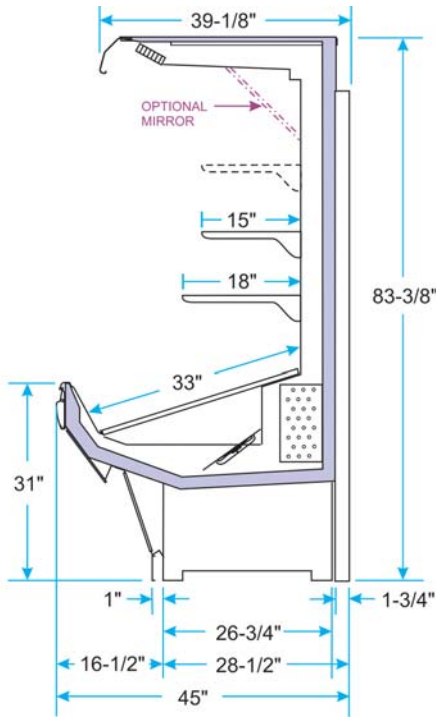

Model	Case Length	Description	Capacity in Cubic Feet*
N5P	8' • 12'	Extended Height Vertical Bulk Produce, standard coil	48.9 • 73.5

* Cubic capacity is based on two rows of 15" shelves and one row of 18" shelves.

Optional Accessories

Mirrors in a variety of sizes combine with multiple depth shelving sizes for merchandising and display flexibility.



Up to four rows of multiple depth shelving with or without lighting maximizes product display facings for merchandising and shopping ease.



3 or 6 position shelf brackets provide the desired shelf angle for optimum product viewing.

