

TYLER

Advantage^{series}

Installation & Service Manual



N6DHPL(LR), N6DHPM(MR), N6DHPH **HIGH PERFORMANCE MULTI-SHELF MERCHANDISER** **Medium Temperature Self Serve Display Cases**

**This manual has been designed to be used in conjunction with the
General (UL/NSF) Installation & Service Manual.**

Save the Instructions in Both Manuals for Future Reference!!

This merchandiser conforms to the American National Standard Institute & NSF International Health and Sanitation standard ANSI/NSF 7 - 2003.

PRINTED IN U.S.A.	Specifications subject to change without notice.	REPLACES EDITION	8/05	ISSUE DATE	12/05	PART NO.	9037176	REV. D
-------------------	--	------------------	------	------------	-------	----------	---------	--------

CONTENTS

	<u>Page</u>
Specifications	
N6DHPL / N6DHPM / N6DHPH / N6DHPLR / N6DHPMR	
Specification Sheets	4
Pre-installation Responsibilities	(See General-UL/NSF I&S Manual)
Installation Procedures	
Carpentry Procedures	7
Case Pull-Up Locations	7
Joining Rear Load Cases to Coolers	7
Refrigeration Procedures	8
Electronic Thermostat Control	8
Electrical Procedures	9
Plumbing Procedures	(See General-UL/NSF I&S Manual)
Defrost Information	9
Defrost Control Chart	9
Installation Procedure Check Lists	(See Gen.-UL/NSF I&S Manual)
Wiring Diagrams	9
N6DHP(L/M/H/LR/MR) Domestic & Export (50Hz) Case Circuits	10
Cleaning and Sanitation	(See General-UL/NSF I&S Manual)
Component Removal and Installation Instructions for Cleaning	13
Shelves and Shelf Brackets	13
Bottom Trays	13
Front Air Ducts	13
Rear Duct Panels	13
Discharge Air Honeycomb	13
Top Duct	13
Front Cladding	14

Installation & Service Manual N6DHP(L, M, H, LR, MR)

	<u>Page</u>
General Information	
NSF Product Thermometer Installation	14
Egg Merchandiser Kit	14
Peg Bar Information	15
Peg Bar Information for Cannon Magna Peg Bar Display Systems	16
Rear Load Air Close-Off Information (N6DHPLR/N6DHPMR) ..	17
Service Instructions	
Preventive Maintenance	(See General-UL/NSF I&S Manual)
Ballast and Lighting Locations	17
Parts Information	
Cladding and Trim Parts List	18
Operational Parts List	20
TYLER Warranty	(See General-UL/NSF I&S Manual)

The following High Performance Medium Temperature, Multi-Shelf Dairy, Deli, Produce and Juice Merchandiser models are covered in this manual:

MODEL	DESCRIPTION
N6DHPL	4', 6', 8' & 12' HIGH PERF. MED. TEMP. MERCHANDISER WITH 18" FRONT
N6DHPM	6', 8' & 12' HIGH PERF. MED. TEMP. MERCHANDISER WITH 22" FRONT
N6DHPH	6', 8' & 12' HIGH PERF. MED. TEMP. MERCHANDISER WITH 26" FRONT
N6DHPLR	8' & 12' HIGH PERF. MED. TEMP. MERCHANDISER WITH 18" FRONT AND REAR DOORS
N6DHPMR	8' & 12' HIGH PERF. MED. TEMP. MERCHANDISER WITH 22" FRONT AND REAR DOORS

SPECIFICATIONS

N6DHP(L, M, H, LR, MR) High Performance Med. Temp. Merchandisers

Refrigeration Data:

MODEL	CASE LENGTH	CASE USAGE	CAPACITY (BTUH / FT)		EVAPORATOR (°F)	UNIT SIZING (°F)	DISCHARGE AIR		AVG. REF. CHARGE (LBS/FT)
			PARALLEL	CONVENTIONAL			TEMPERATURE (°F)	VELOCITY (FPM)	
N6DHPL	4'/6'/8'/12'	MED TEMP	1,106*	1,185*	+28**†	+26†	+34†	250***	0.48****
N6DHPM	6'/8'/12'	MED TEMP	1,061*	1,137*	+28**†	+26†	+34†	250***	0.48****
N6DHPH	6'/8'/12'	MED TEMP	1,017*	1,090*	+28**†	+26†	+34†	250***	0.48****
N6DHPLR	8'/12'	MED TEMP	1,504*	1,817*	+28**	+26	+31	178***	0.48****
N6DHPMR	8'/12'	MED TEMP	1,458*	1,589*	+28**	+26	+31	178***	0.48****

* Capacity data listed for cases with optional 2 rows of T-8 canopy lights and 4 rows of unlighted 22" deep shelves. Adjustments must be made to this base rating for each option installed on this case. ADD 20 BTUH/FT for each row of lighted shelves. For cases using peg bars, ADD 132 BTUH/FT to parallel load or ADD 183 BTUH/FT to conventional load. NOTE: Baffles are required above each peg bar row to provide proper air flow around the food products. For sizing all refrigeration equipment other than TYLER, use conventional BTUH values.

** Evaporator temperature is based on the saturated pressure leaving the case.

*** Air velocity measured 1 hour after defrost at the top discharge air duct using an ALNDR J.R. velometer with a scoop. DEDUCT 20 FPM for case using peg bars.

**** This is an average refrigeration charge per foot based on R22 and R404A refrigerant usage.

† ADD 2°F for case using produce insert.

FOR SPECIFIC COMPRESSOR SIZING AND/OR LINE SIZING INFORMATION, REFER TO THE "GOLD" AND/OR "BUFF" SECTIONS IN THE TYLER SPECIFICATION GUIDE.

Electrical Data:

Fans and Heaters (120 Volt)

MODEL	CASE LENGTH	FANS / CASE	TOTAL STANDARD FANS		TOTAL ECM FANS		TOTAL ANTI-SWEATS	
			AMPS	WATTS	AMPS	WATTS	AMPS	WATTS
N6DHPL	4'	1	0.36	42	0.35	26	N/A	N/A
N6DHP(L/M/H)	6'	2	0.72	84	0.70	52	N/A	N/A
N6DHP(L/M/H)	8'	2	0.72	84	0.70	52	N/A	N/A
N6DHP(L/M/H)	12'	3	1.08	126	1.05	78	N/A	N/A
N6DHP(LR/MR)	8'	2	0.72	84	0.70	52	N/A	N/A
N6DHP(LR/MR)	12'	3	1.08	126	1.05	78	N/A	N/A

T-8 Lighting with Electronic Ballasts (120 Volt)

MODEL	CASE LENGTH	CANOPY LIGHTS* -- PER ROW				SHELF LIGHTS -- PER ROW										NOSE LIGHT		MAX LIGHTING (# ROWS)	
		AMPS		WATTS		AMPS					WATTS					AMPS	WATTS	AMPS	WATTS
		1	2	1	2	1	2	3	4	5	1	2	3	4	5				
N6DHPL	4'	0.35	0.50	42	60	0.45	0.60	0.80	0.95	1.30	54	72	96	114	156	0.35	42	2.15	258
N6DHP	6'	0.40	0.75	48	90	0.60	0.90	1.20	1.50	1.90	72	108	144	180	228	0.40	48	3.05	366
N6DHP(R)	8'	0.50	0.95	60	114	0.90	1.20	1.60	1.90	2.40	108	144	192	228	288	0.50	60	3.85	462
N6DHP(R)	12'	0.70	1.40	84	168	1.35	1.80	2.40	2.85	3.55	162	288	288	342	426	0.70	84	5.65	678

* Standard lighting for this case is 1 row of canopy lights.

Defrost Data:

DEFROST TYPE*	DEFROSTS PER DAY	DURATION TIME (MIN)**	ELEK. THERMOSTAT / AIR SENSOR SETTINGS			EPR SETTINGS ***		CONVENTIONAL COMPRESSOR SETTINGS****				DEFROST WATER (LB / FT / DAY)
			USAGE	CUT IN	CUT OUT	R22 (PSIG)	R404A (PSIG)	R22 CUT-IN	R22 CUT-OUT	R404A CUT-IN	R404A CUT-OUT	
TIME OFF	6	16	SHELVING	34°F	32°F	52	66	50°F	36°F	64°F	47°F	4.3
TIME OFF	6	18	PEG BARS / MIXED****	32°F	30°F	50	64	48°F	36°F	62°F	47°F	6.8
TIME OFF	6	16	PRODUCE INSERT	36°F	34°F	55	70	53°F	36°F	67°F	47°F	1.6
TIME OFF	6	16	REAR LOAD	32°F	30°F	52	66	50°F	36°F	64°F	47°F	4.3

* All high performance cases use OFF CYCLE defrost.

** NOTE: 16 or 15 minutes is for EPR with suction stop for defrost isolation. Defrost times increases by four minutes when defrost isolation is by pump down.

*** If EPR is utilized, use the settings shown in the chart. ADD 0.5# to EPR setting for each 1000 foot rise in elevation.

**** NOTE: Mixed line-up is peg bars mixed with shelving in same line-up.

***** Recommended setup for a conventional unit uses an electronic thermostat to assure accurate temperature control.

CASE CIRCUITS: This case requires a 120V circuit for fans and lights.

SHELVING NOTES: Shelving widths available for these cases are 15", 18", 20" and 22". When two sizes are used, the smaller must be on top.

CASE BTUH REQUIREMENTS are calculated to produce approximately the indicated entering-air temperature with absolute maximum operating ambient limits of 75°F & 55RH

The information contained herein is based on technical data and tests that we believe are reliable, and is intended for use by persons having technical skill at their own discretion and risk. Since conditions of use are outside of Tyler's control, we cannot assume any liability for results obtained or damages incurred through the application of the data presented. SPECIFICATIONS ARE SUBJECT TO CHANGE WITHOUT NOTICE.

Installation & Service Manual **N6DHP(L, M, H, LR, MR)**

CASE-TO-CASE SUCTION LINE SUB-FEED BRANCH LINE SIZING														
MODEL	4'	6'	8'	12'	16'	20'	24'	28'	32'	36'	40'	44'	48'	52'
N6DHP(R) / R22	7/8"	7/8"	7/8"	7/8"	7/8"	1 1/8"	1 1/8"	1 1/8"	1 1/8"	1 3/8"	1 3/8"	1 3/8"	1 3/8"	1 3/8"

N6DHP CROSS SECTION

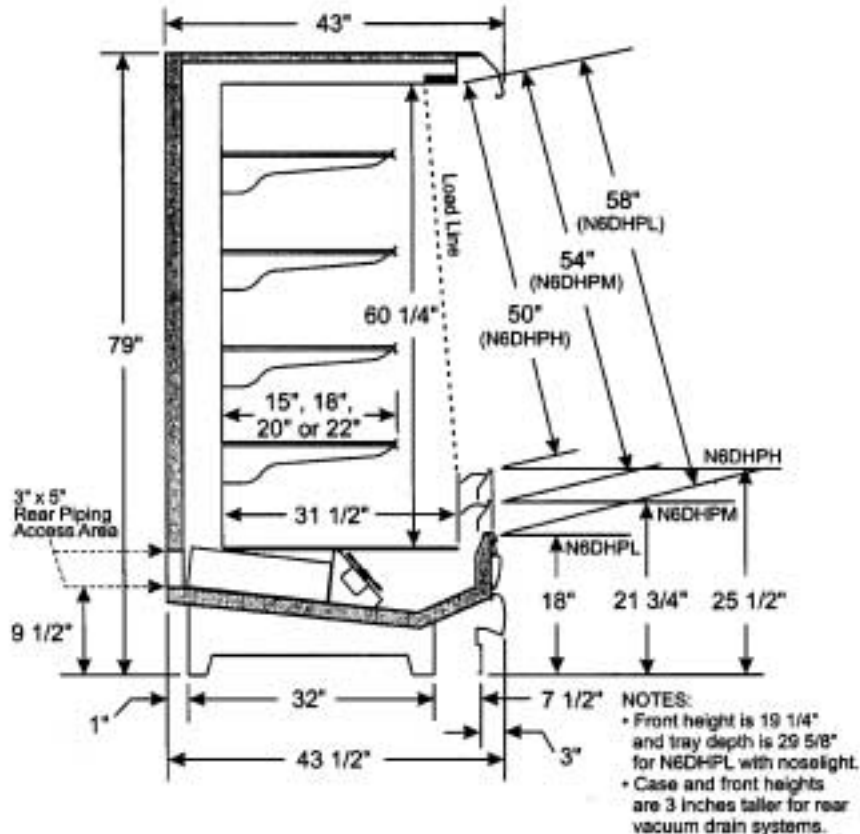

FLOOR PLAN

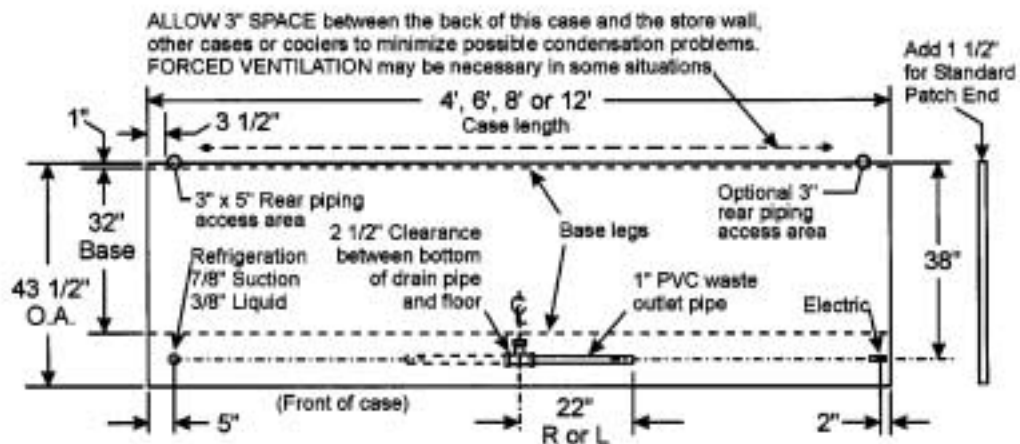

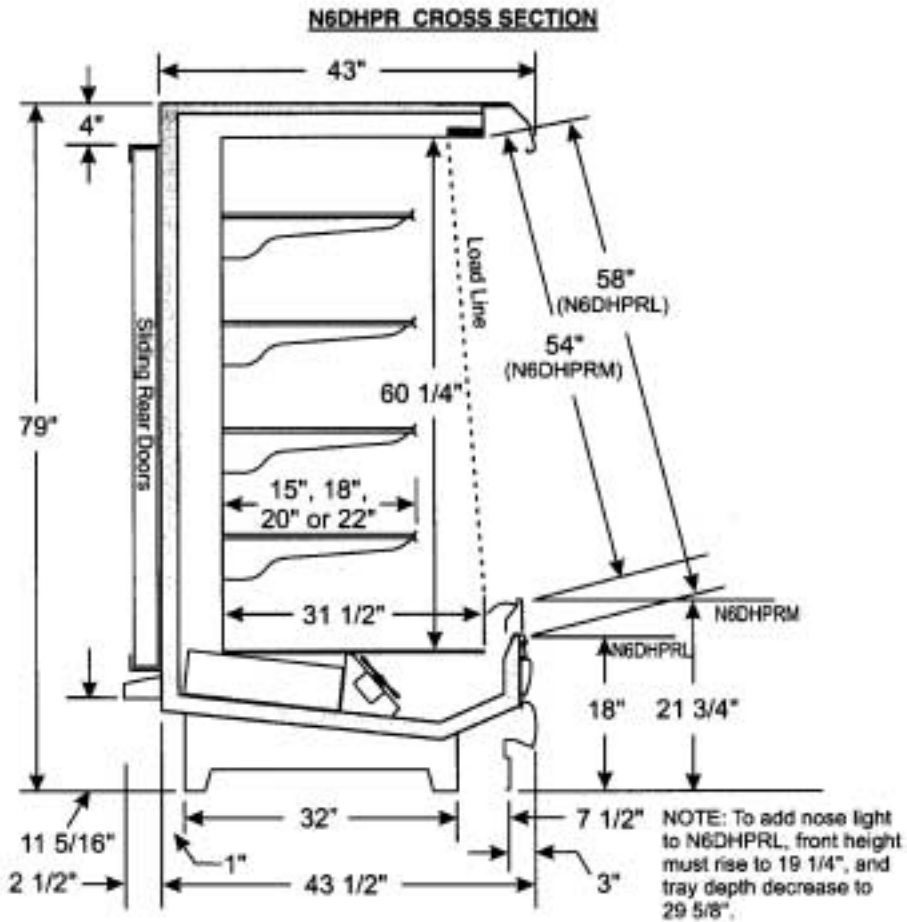

INSTALLATION PROCEDURES

Carpentry Procedures

Case Pull-Up Locations

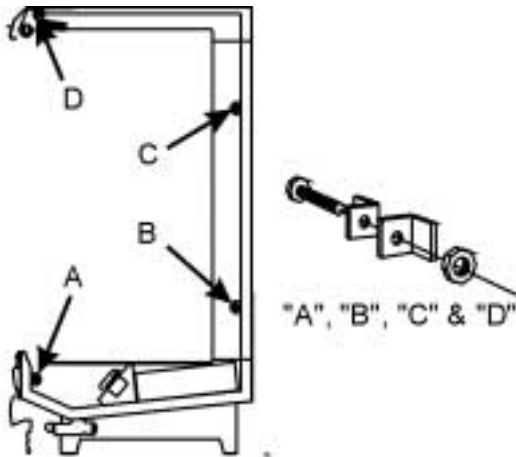

All N6DHP models have four pull-ups at each end of the case. Pull-ups A, B, C and D are located as shown and should be installed and tightened starting with A and finishing with D.

NOTE

If extra pull-up bolts are needed, use the bolts from the side shipping supports.

See "General-UL/NSF I&S Manual" for line-up assembly instructions.

Joining Rear Load Cases to Coolers (N6DHPLR and N6DHPMR only)

For U.L. and temperature performance requirements, N6DHPLR and N6DHPMR cases must be backed by a refrigerated area. TYLER walk-in coolers are available with the necessary special parts and instructions to make the installation.

NOTE

Please ensure that the cooler opening is insulated and sealed completely to the rear of the display case.

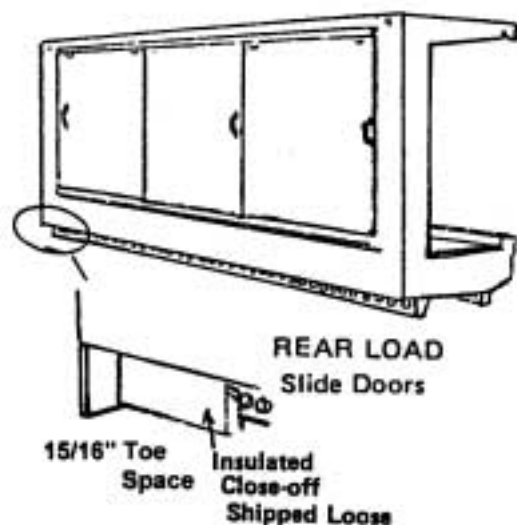
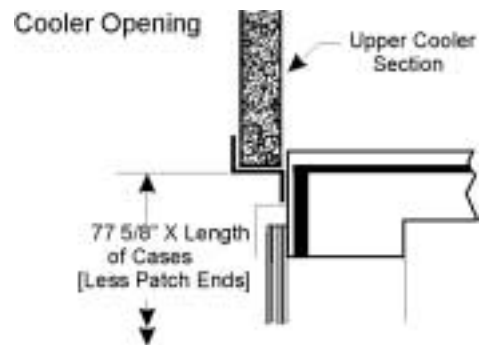

Refrigeration Procedures

Refrigeration system and superheat instructions can be found in the “General (UL/NSF) I&S Manual”. Case electronic temperature control information is listed below.

Electronic Temperature Control

Whenever an N6DHP uses an electronic thermostat and solenoid valve for temperature control, use the following instructions to properly set-up the electronic thermostat.

Setting the Electronic Thermostat

1. Remove the four screws and cover from the electronic thermostat.
2. Connect sensor wires to the common (COM) and sensor (SEN) terminals of the terminal strip located at the top left of the printed circuit board. The sensor leads are interchangeable.

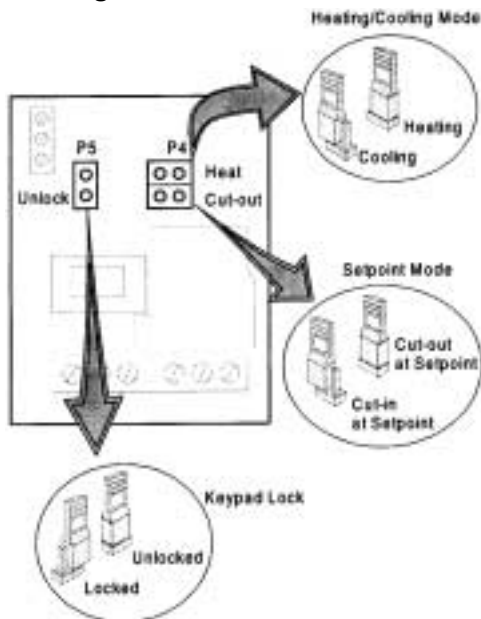

3. Set the Heating/Cooling jumper blocks to the “COOL” position.
4. Set the Cut-in at Setpoint/Cut-out at Setpoint jumper blocks to the “Cut-out at Setpoint” position.
5. Set the keypad Locked/Unlocked jumper blocks to the “Unlocked” position.
6. Replace the electronic thermostat cover and secure with four screws.

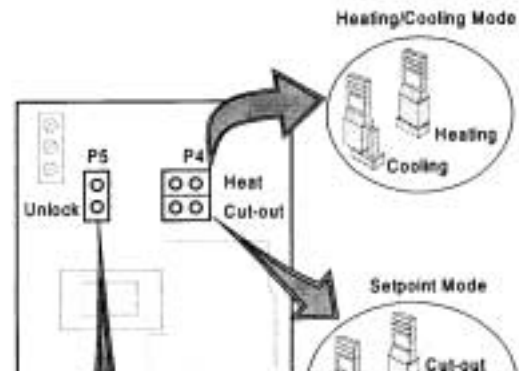

7. To adjust the setpoint:
 - a. Push the Menu Button. “SP” will flash on the LCD display.
 - b. Push the Menu Button one more time and a setpoint temperature will be displayed.
 - c. Push the Up or Down Button until the desired setpoint is displayed.
 N6DHP (w/shelving, peg bars or mixed) = 32°F
 N6DHP (w/produce insert) = 34°F
 - d. Push the Menu Button.
8. To adjust the differential:
 - a. Push the Menu Button. “SP” will flash on the LCD display.
 - b. Push the Down Button until “DIF” is shown on the LCD display.
 - c. Push the Menu Button one more time and a differential number will be displayed.
 - d. Push the Up or Down Button until the desired differential setting is displayed.
 N6DHP (all applications) = 2°F
 - d. Push the Menu Button.

With the cooling mode selected, the differential is ABOVE the setpoint. The relay will energize and the LED indicator will illuminate when the temperature reaches the differential setting. When the temperature drops to the setpoint, the relay and LED indicator will de-energize and refrigeration will stop.

The settings above are specific to TYLER N6DHP cases. Other applications will require different setpoints and differentials.

Installation & Service Manual N6DHP(L, M, H, LR, MR)

Electrical Procedures

Electrical Considerations

CAUTION

Make sure all electrical connections at components and terminal blocks are tight. This will prevent burning of electrical terminals and/or premature component failure.

NOTE

Raceway covers will be shipped loose. See the "General-UL/NSF I&S Manual" for raceway cover installation and removal instructions.

Case Fan Circuit

This circuit is to be supplied by an uninterrupted, protected 120V circuit. The case fan circuit is not cycled.

Fluorescent Lamp Circuit

The standard case lighting system is 800MA T-12 high output (HO) lamps. The standard lighting is 1-row of horizontal canopy lights.

Defrost Information

See "General-UL/NSF I&S Manual" for operational descriptions for each type of defrost control.

Defrost Control Chart

Defrost Type	Defrosts Per Day	Defrost Duration (Min)
Off Time (w/ shelves or produce inserts)	6	16*
Off Time (w/ peg bars or mixed)	6	18*
Off Time (rear load)	6	16*

***16 or 18 minutes is for EPR only. Defrost duration increases by 4 minutes when controller methods do not include an EPR valve.**

WIRING DIAGRAMS

ELECTRICIAN NOTE - OVERCURRENT PROTECTION

120V circuits should be protected by 15 or 20 Amp devices per the requirements noted on the cabinet nameplate or the National Electrical Code, Canadian Electrical Code - Part 1, Section 28. 208V defrost circuits employ No. 12 AWG field wire leads for field connections. On remote cases intended for end to end line-ups, bonding for ground may rely upon the pull-up bolts.

The following wiring diagrams on pages 10, 11 and 12 will cover the N6DHP and N6DHPR case circuits. The defrost and lighting circuits are covered in the case circuit diagrams.

N6DHPL Dom. & Exp. (50Hz) Case Circuits (4' Cases)

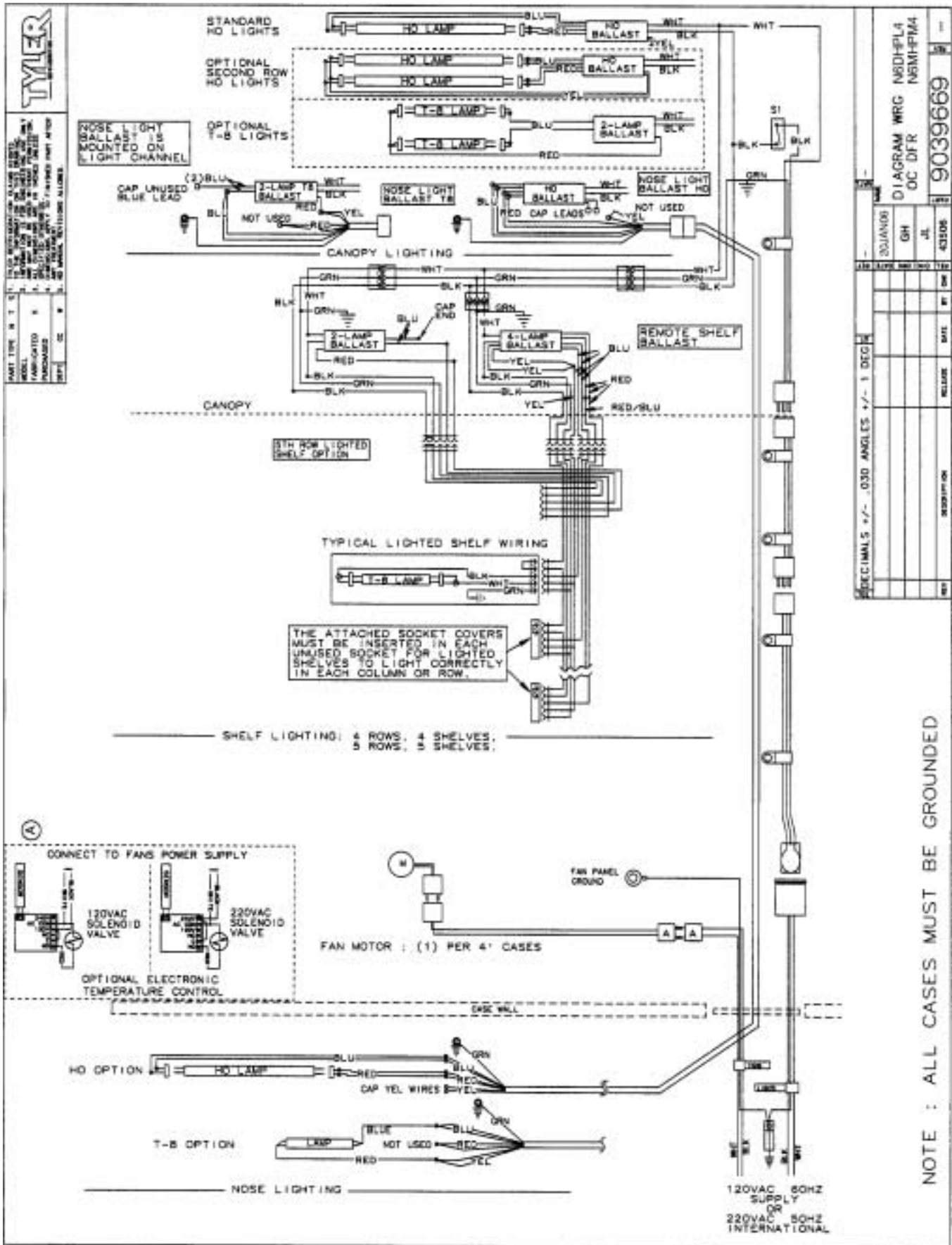

N6DHP(L, M, H, LR, MR) Dom. & Exp. (50Hz) Case Circuits (6' & 8' Cases)

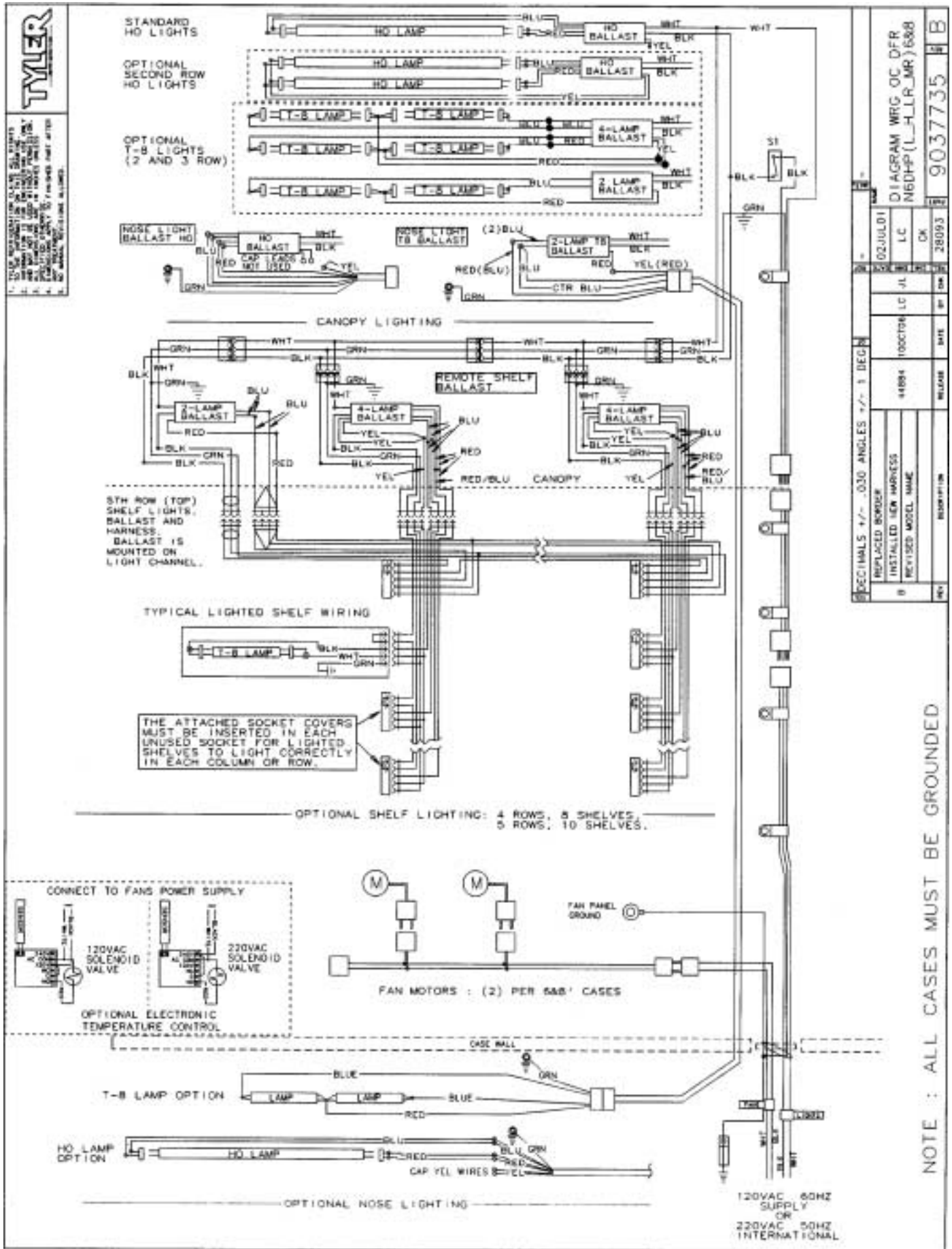

N6DHP(L, M, H, LR, MR) Dom. & Exp. (50Hz) Case Circuits (12' Cases)

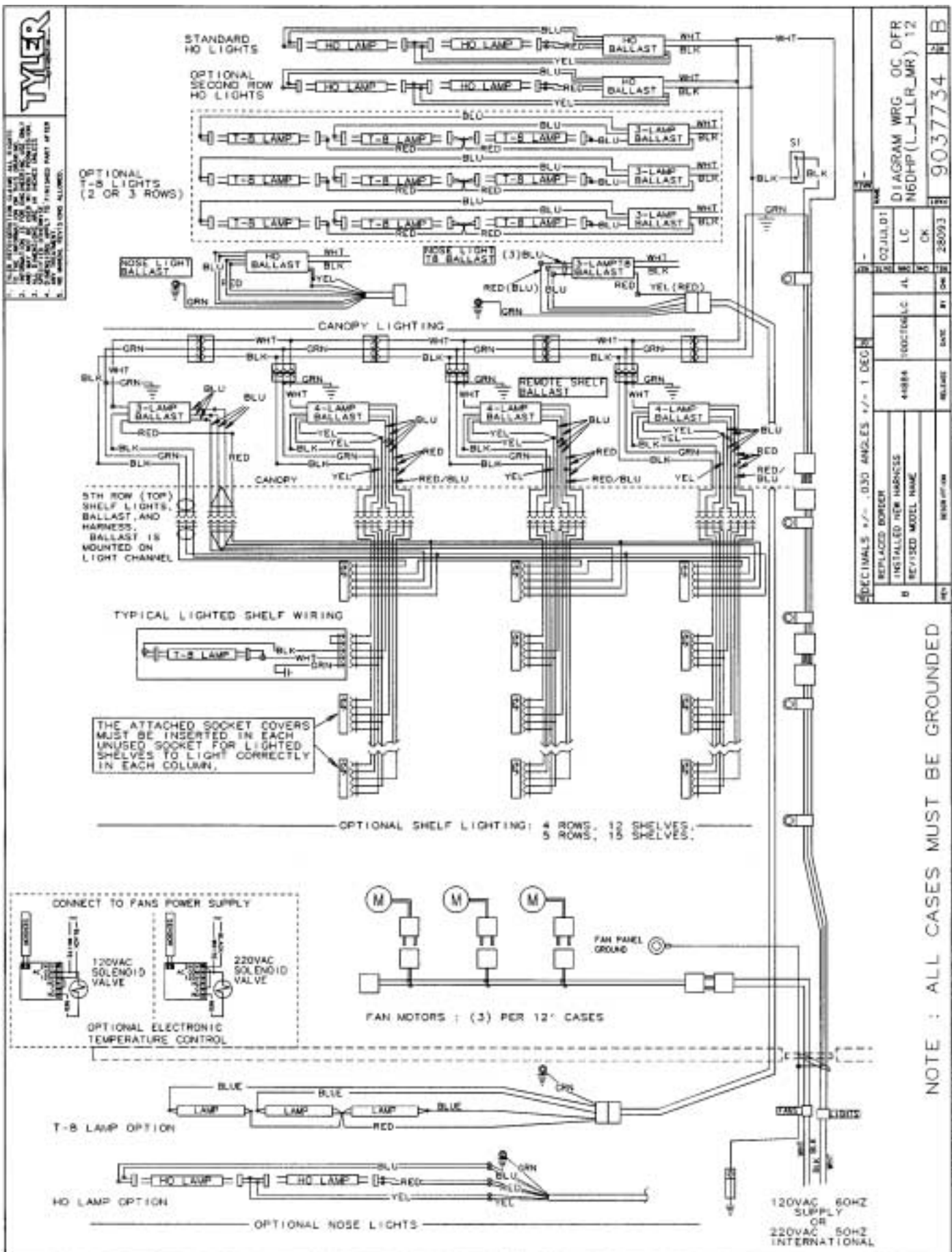

CLEANING AND SANITATION

Component Removal and Installation Instructions for Cleaning

Shelves and Shelf Brackets

1. Remove product from shelves.
2. If shelf has a light, unplug the light cord from the socket in the rear duct panel. Completely insert socket cover in the light socket to protect the receptacle.
3. Push shelves back and then lift up and out to remove them from the shelf brackets.
4. Remove shelf brackets from slots in rear uprights.
5. After cleaning, replace in reverse order.

Bottom Trays

1. Remove product from bottom of case.
2. Grasp and lift out each of the bottom trays from the case interior.
3. After cleaning, replace in reverse order.

Front Air Ducts

1. Remove lower trays, see this page.
2. Lift out front air duct sections.
3. After cleaning, replace in reverse order.

Rear Duct Panels

(w/o Shelf Light Sockets)

1. Remove shelves and bottom trays, see above.
2. Remove mounting screws and rear duct panels from case.
3. After cleaning, replace and secure rear duct panels in reverse order.

(with Shelf Light Sockets)

1. Remove shelves and bottom trays, see above.
2. For cases with 5 rows of lighted shelves, remove screw above top shelf socket and push socket assembly back through the hole in the rear duct panel.

3. Remove mounting screws from rear duct panel.
4. Slowly lift out rear duct panel until the shelf harness connector near the top of the panel can be accessed.
5. Disconnect shelf harness connector and complete removing the rear duct panel.

WARNING

Rear duct panels with electrical receptacles can be cleaned without removing the electrical receptacles. Do not get moisture on electrical wires when cleaning under this cover. Moisture on wires could cause premature product failure and/or personal injury or death from electrical shock.

6. After cleaning, reconnect the shelf harness connector: install the top socket assembly: replace and secure rear duct panels in reverse order.

Discharge Air Honeycomb

1. Loosen screws securing rear retainer plate.

NOTE

Note position of the honeycomb grid during removal so it can be reinstalled the same way.

2. Slide rear retainer plate back until the honeycomb grid sections can be removed from the top duct.

CAUTION

Improper installation of the honeycomb grid section could result in improper air flow and/or poor refrigeration.

3. After cleaning, replace honeycomb grid sections as they were removed and secure with the rear retainer plate and screws.

Top Duct

1. Remove shelves and shelf brackets, see above.
2. Remove screws, rear retainer plate and honeycomb grid sections from top of case.
3. Remove screws and top duct from case.
4. After cleaning, replace top duct and remaining components in reverse order.

Front Cladding

1. Remove front kickplate and raceway cover. (See General-UL/NSF I&S Manual.)
2. Remove color band, bumper and bumper retainer from the case. (See General-UL/NSF I&S Manual.)
3. Remove screws for top and bottom of front cladding and remove cladding.
4. After cleaning, replace front cladding and remaining front components in reverse order.

GENERAL INFORMATION

NSF Product Thermometer Installation

1. Unwrap the thermometer and bracket assembly shipped loose with the case.

NOTE

Recommended bottom tray position is with the lips up.

2. Position bracket in front right corner of the left-most bottom tray. Making sure the bracket is flush with the left edge, use the bracket holes as a template for where to drill the holes.
3. Drill two .196" holes in the bottom tray.

NOTE

For ease of installation, position the washers and capnuts on the top side of the bracket and bottom tray.

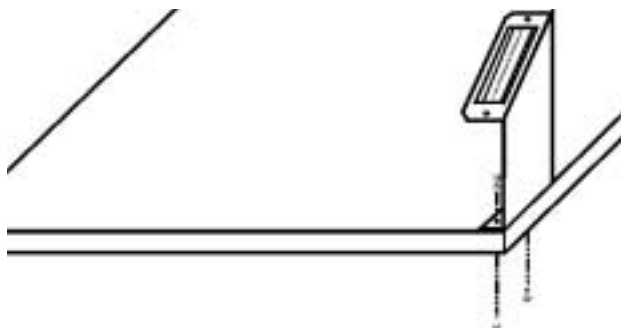

4. Mount the bracket to the bottom tray with two screws, washers and capnuts.

Egg Merchandiser Kit Instruction

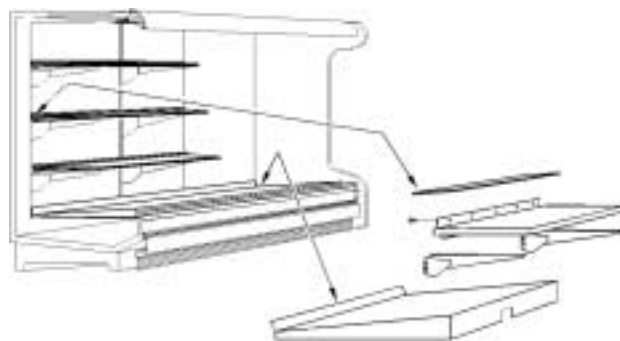

All egg shelves come galvanized or stainless steel. The upper egg shelves are 15" x 48" and come with 82 degree fixed white brackets. The brackets are available in one position only. The upper egg shelves assemblies include a rear air close-off.

Tilted base egg shelves come in 4' modules. They are designed and notched to fit inside the existing 2' bottom trays.

NOTE

Egg shelves are designed to catch and hold spilled liquids so they can be cleaned up before getting further into the case. If the tilted base shelves are used upside down, improper shelf support will result causing the middle of each shelves to sag. Upside down usage also allows drippage to get into the case making cleaning very difficult. Good sanitation is essential for egg merchandising.

Peg Bar Information (All Models)

The hang up blister pack has become a standard means of marketing sliced luncheon meats and other delicacies. It appears that all that is needed to adapt multi-shelf cases for these packages is to add peg bars and pegs. However, it isn't quite that simple, because the removal of shelves changes more than the appearance of the case.

Figure 1 shows the air flow in a Multi-Deck display merchandiser with shelves. Air flow from the top and back forms a protective barrier to ambient air.

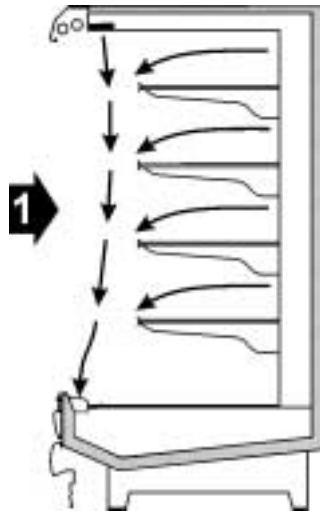

Figure 2 shows what happens to the air flow when the shelves are removed. The air drifts back to the rear duct and swirls about. This breaks the protective barrier, causing the case air to mix with ambient air to a great extent.

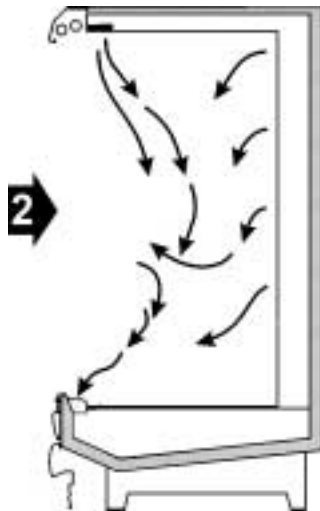
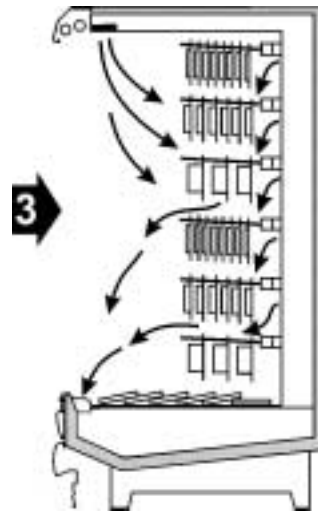
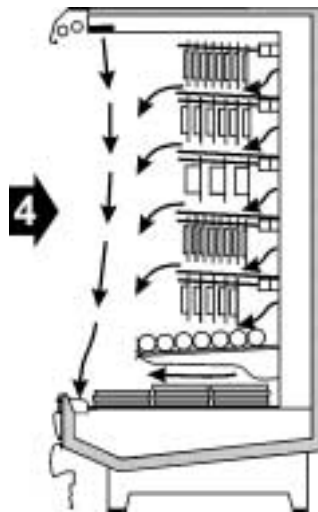

Figure 3 depicts what happens to the air flow in a case full of peg bars. The air falls through openings between packages and fails to maintain a protective barrier. When the bars are fully stocked, the effect is minimized, but product temperatures will not be as good as they could be. Sweating may be noticed on the top duct panel above the bars. The coil will also frost faster, requiring more frequent defrosts.



When the bars are fully stocked, the effect is minimized, but product temperatures will not be as good as they could be. Sweating may be noticed on the top duct panel above the bars. The coil will also frost faster, requiring more frequent defrosts.

Figure 4 shows the proper air flow for cases with peg bars. The addition of a baffle above each row of peg bars, except the top row and a bottom shelf, maintains proper air flows and temperatures in the case. Non-load bearing air baffles should run the same width as the peg bars.



CAUTION

Always use one row of shelves below the lowest row of peg bars. Use air baffles above each row of peg bars, except the top row. The air baffle should be solid in design and positioned 1" in front of the rear duct and 5.5" back from the rear edge of the card moulding. This provides and maintains the protective air flow in the case and proper product cooling and storage.

Peg Bar Information for Cannon Magna Peg Bar Display Systems (TYLER supplied)

Air baffle shelves should always be used with peg bars for hanging meat displays. Air baffle shelves are non-load bearing and are used only to help direct the air flow. The air baffles should be installed above each row of peg bars, except the top row, along with a bottom shelf. Air baffles are available from TYLER that are compatible with 15" offset support arms.

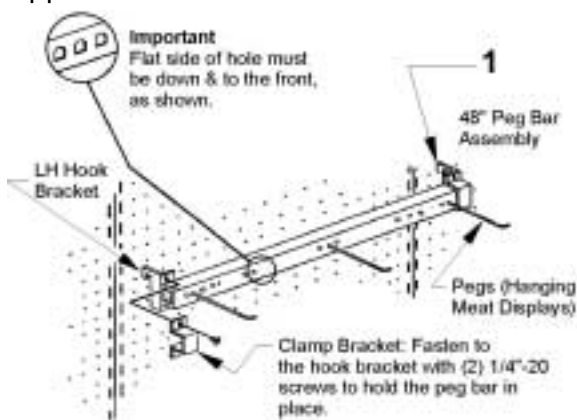

1. 48" peg bar with 52 holes to accept pegs. Flat side of holes in peg bar must be down and to the front of the bar. Attach two hook brackets to peg bar with two clamp brackets and four screws. Position and install peg bar in slotted holes in back of case.

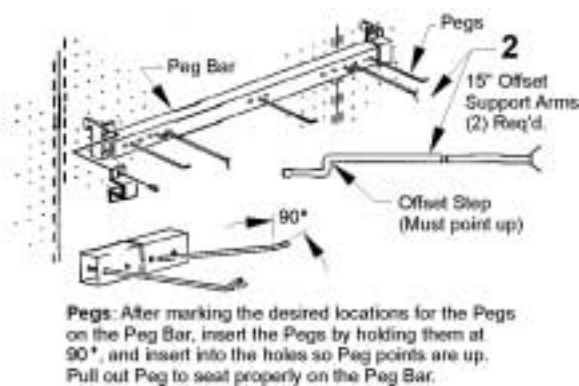

2. 15" pegs and offset support arms lock in place on the peg bar. After marking the desired locations in the peg bar, install the pegs into peg bar holes. Hold peg at 90° angle to peg bar. Insert peg into hole in peg bar. Rotate peg until angled end

points up. Pull peg out until peg sits properly in the peg bar.

Offset support arms must be installed in the peg bar so the notches in the air baffle can fit over them. Install support arms in the same manner as the pegs (with offset up).

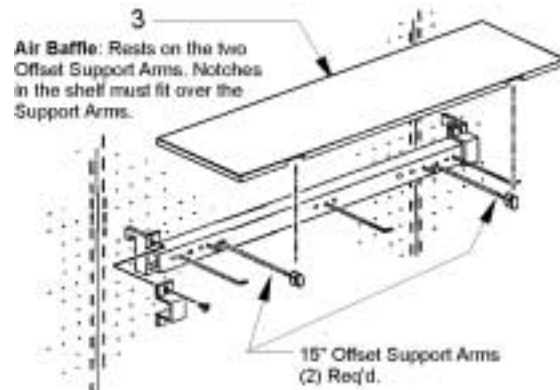

3. Non-load bearing air baffle should run the same width as the peg bar. Air baffle rests on the two offset support arms. The notches in the air baffle must fit over the support arms. **NOTE: The air baffle should be solid in design and positioned 1" in front of the rear duct and 5.5" back from the rear edge of the card moulding.**

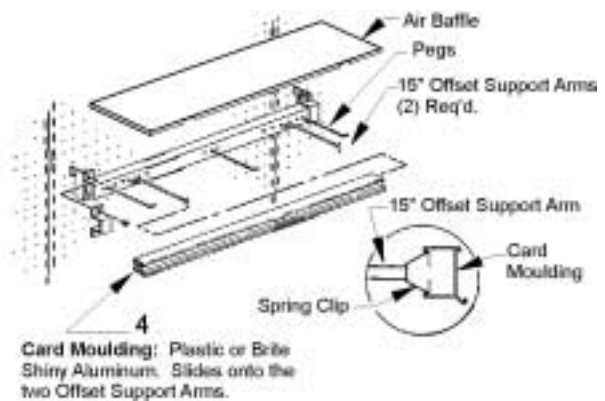

4. Card moulding is offset 2" in front and 3/4" above the pegs.

Slide the card moulding onto the two offset support arms. Center the card moulding so it is aligned with the peg bar. Secure the card moulding on the offset support arms with two spring clips. To remove card moulding, squeeze each spring clip together until the card moulding releases.

Installation & Service Manual **N6DHP(L, M, H, LR, MR)**

TYLER 8 and 12 foot cases have four foot sections for merchandising. 6 foot cases have three foot sections for merchandising. Further guidelines for section to section merchandising are listed below:

There are three basic ways that peg bars are used in our cases:

All peg bars at the same elevation: TYLER recommends that peg bar rows in adjacent sections of a case (including baffles) be installed at the same elevation. This will ensure that air flow from the perforated rear duct panels flows in and around the food products displayed on the pegs to best maintain the foods at the desired core product temperatures.

Peg bars at different elevations: If you choose this merchandising method, TYLER recommends that a vertical plexiglas partition be installed between the adjoining sections. This will ensure that air flow from the perforated rear duct panels flows in and around the food products displayed on the pegs to best maintain the foods at the desired core product temperatures.

Peg bars adjacent to TYLER shelving: TYLER recommends a vertical plexiglas partition be installed between the adjoining sections. This will ensure that air flow from the perforated rear duct panels flows in and around the food products displayed on the pegs to best maintain the foods at the desired core product temperatures.

Rear Load Air Close-Off Information

NOTE

The air close-off/product stops are attached to the shelves at the factory.

- **8' cases use 32 1/2" air close-offs.**
- **12' cases use 32 1/2" RH & LH side air close-offs and 37 1/4" center air close-offs.**

Shelves are shipped in the proper position. If shelves are removed, be sure they are

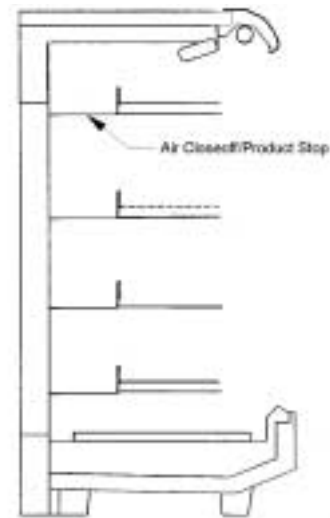

replaced in the proper order. It is necessary for proper air flow in the case. Omit shelf shown by dotted line for cases with only three rows of shelves.

SERVICE INSTRUCTIONS

See "General-UL/NSF I&S Manual" for T-8 and 800MA T-12 lamp, canopy ballast, fan blade and motor, and color band and bumper replacement instructions.

Ballast and Lighting Locations

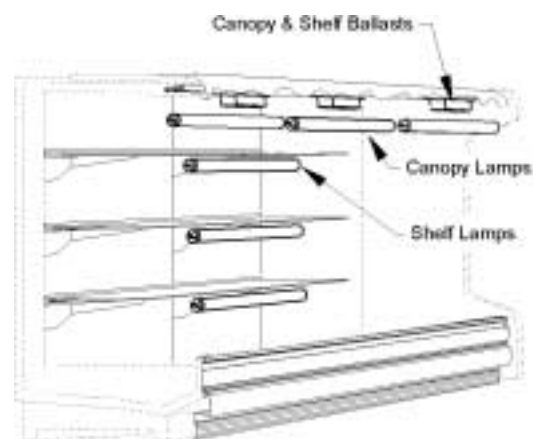

All light ballasts are located under the canopy and mounted above or on the top of the canopy light channel. This includes remote ballasts for optional shelf lights and optional nose lights. The canopy light(s) are under the canopy light channel in the top of the case. The optional shelf lights are mounted under the top interior liner above each shelf section.

PARTS INFORMATION

Cladding and Trim Parts List

Item	Description	4'	6'	8'	12'
1	Screw	5183536 (4)	5183536 (4)	5183536 (6)	5183536 (8)
2	Screw	5183536 (8)	5183536 (8)	5183536 (8)	5183536 (8)
3	End Cover	9026103 (2)	9026103 (2)	9026103 (2)	9026103 (2)
4	Canopy Joint Trim	9029422	9029422	9029422	9029422
5	Canopy Hood, Ptd.	9025221	9025222	9025223	9025224
6	Front Panel	9311775	5636774	5203468	5203469
7	Hand Rail/Bumper Retainer	----- color per order -----			
8	Hand Rail Backer	9025316	9025316	9025316	9025316
9	Bumper End Trim	----- color per order -----			
10	Color Band, Ptd.	9023790	9023795	9023798	9023800
11	Color Band Backer, Ptd.	9040223	9040223	9040223	9040223
12	Bumper Backer	----- color per order -----			
13	Bumper	----- color per order -----			
14	Front Cladding, Ptd.				
	(N6DHPL)	9311746	9025135	9025136	9025137
	(N6DHPM)	9304843	9025647	9025648	9025649
	(N6DHPH)	----	9300395	9025650	9025651
	(N6DHPLR)	----	----	9025648	9025649
	(N6DHPMR)	----	----	9025650	9025651
15	Raceway Cover	----- color per order -----			
16	Raceway Cover Retainer	9023841 (2)	9023841 (2)	9023841 (4)	9023841 (6)
17	Screw (per retainer)	5183536 (2)	5183536 (2)	5183536 (2)	5183536 (2)
18	Screw	5183536 (5)	5183536 (7)	5183536 (9)	5183536 (12)
19	Raceway Cover End Trim	----- color per order -----			
20	Raceway Cover Backer	----- color per order -----			
21	Kickplate Joint Trim, Ptd.	9039020	9039020	9039020	9039020
22	Metal Kickplate, Ptd.	9324388	9324394	9324402	9324407
23	Shoulder Screw	9025833 (8)	9025833 (6)	9025833 (8)	9025833 (8)
24	Kickplate Support Assy.	9043402 (4)	9043402 (3)	9043402 (4)	9043402 (4)
25	Screw	5183536 (4)	5183536 (8)	5183536 (12)	5183536 (16)
26	Raceway Support	9041322 (4)	9041322 (4)	9041322 (6)	9041322 (8)
27	Raceway	9311760	9300242	9300243	9300244
28	Screw, Shoulder	9025833 (8)	9025833 (12)	9025833 (16)	9025833 (24)

Installation & Service Manual **N6DHP(L, M, H, LR, MR)**

Item Description	4'	6'	8'	12'
29 Horizontal End Trim (N6DHP)	5211585	5211585	5211585	5211585
(N6DHPR)	-----	-----	5211585	5211585
30 Pop Rivet	5105037 (5)	5105037 (5)	5105037 (10)	5105037 (14)

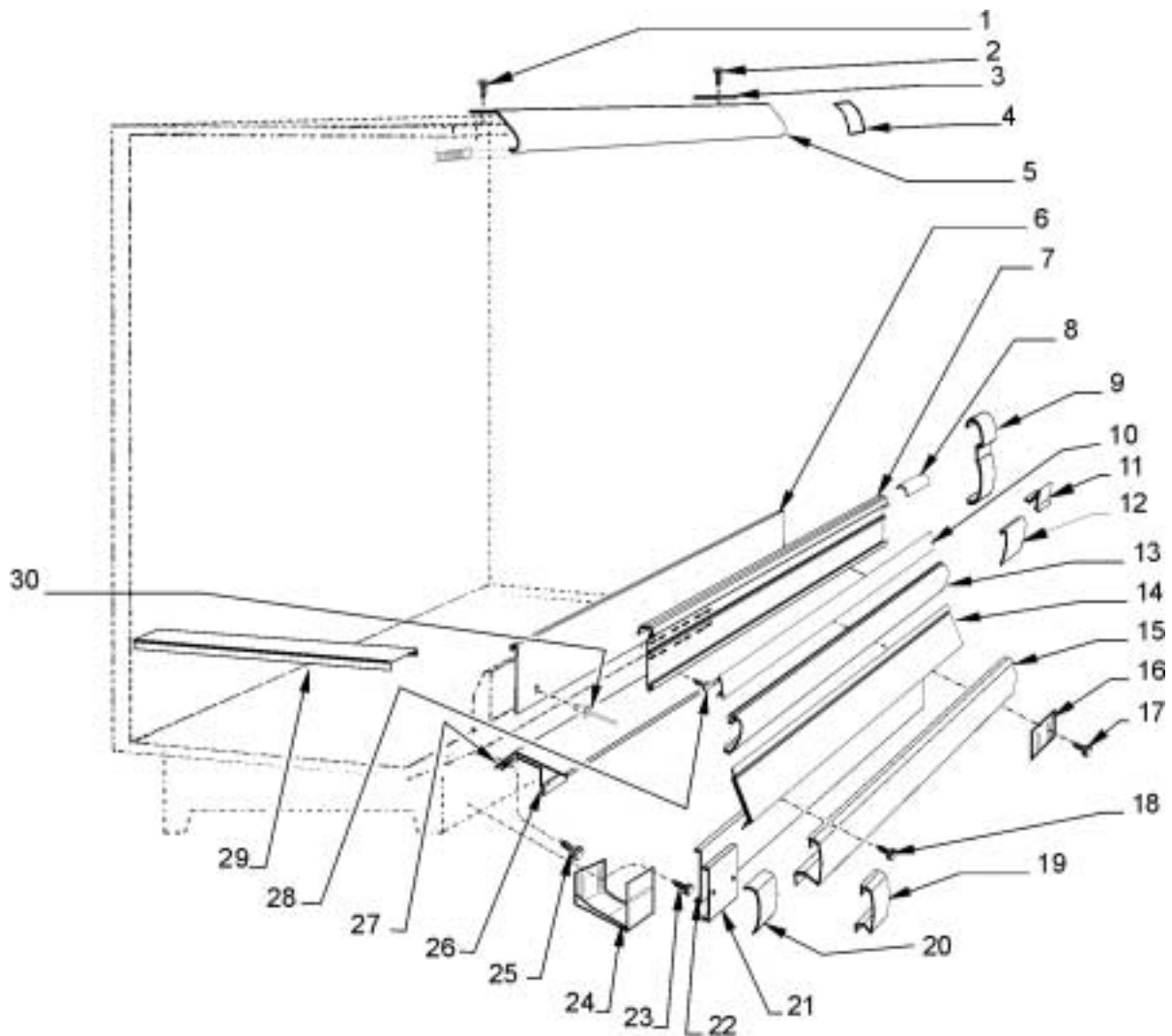

N6DHPM ILLUSTRATED

Operational Parts List

Case Usage	Domestic			
	4'	6'	8'	12'
Electrical Circuit	115 Volt 60 Hertz			
Case Size	4'	6'	8'	12'
Fan Motors	9329327 16 Watt	9329327 16 Watt	9329327 16 Watt	9329327 16 Watt
Opt. Fan Motor (Export) (N6DHPL/M/H only)	9458941 16 Watt	9458941 16 Watt	9458941 16 Watt	9458941 16 Watt
Fan Motor Brackets	5205112	5205112	5205112	5205112
Fan Bracket Plate	9041077	9041077	9041077	9041077
Fan Blades				
(8.75" 30° 5B)(N6DHP)	9407319	9407319	9407319	9407319
(8.75" 37° 5B)(N6DHPR)	-----	-----	9305517	9305517
Opt. ECM Fan Motors (N6DHPL/M/H only)	9025003 16 Watt	9025003 16 Watt	9025003 16 Watt	9025003 16 Watt
Opt. ECM Fan Motor Brackets	5205112	5205112	5205112	5205112
Opt. ECM Fan Blades (8.75" 27° 5B)	9311926	9311926	9311926	9311926
800MA Ballast (one lamp)	5049140	5049140	5049140	5049140
800MA Ballast (two lamp)	5049140	5049140	5204769	5049140
Opt. Ballast (T-8 shelf lamps)	5966635	5966635	5966635	5966635
Opt. Ballast (5th row shelf lamp)	5991029	5991029	5991029	5991030
T-8 Shelf Lampholder	5232279	5232279	5232279	5232279
800MA Lampholder				
(telescoping)	5614628	5614628	5614628	5614628
(stationary)	5614629	5614629	5614629	5614629
Light Switch	5100565	5100565	5100565	5100565
NSF Product Thermometer	5967100	5967100	5967100	5967100

For information on operational parts not listed above contact the TYLER Service Parts Department.