

SPECIFICATION SHEET

• N6DN NARROW MULTISHELF DAIRY/DELI/PRODUCE/JUICE MERCHANDISERS •

Refrigeration Data:

MODEL	CASE LENGTH	CASE USAGE	CAPACITY (BTUH / FT)		EVAPORATOR (°F)	UNIT SIZING (°F)	DISCHARGE AIR		AVG. REF. CHARGE (LBS/FT)
			PARALLEL	CONVENTIONAL			TEMPERATURE (°F)	VELOCITY (FPM)	
N6DNL	4'6"/8'/12'	MED TEMP	1,259*	1,361*	+21**	+19	34	285***	0.71****
N6DNM	6'/8'/12'	MED TEMP	1,215*	1,313*	+21**	+19	34	285***	0.71****
N6DNH	6'/8'/12'	MED TEMP	1,171*	1,266*	+21**	+19	34	285***	0.71****

* Capacity data listed for cases with 2 rows of T-8 canopy lights and 4 rows of unlighted shelves. Adjustments must be made to this base rating for each option installed on this case. ADD 23 BTUH/FT for each row of lighted shelves. NOTE: Contact TYLER for Peg Bar or Produce Insert Capacity Adjustments. For sizing all refrigeration equipment other than TYLER, use conventional BTUH values.

** Evaporator temperature is based on the saturated pressure leaving the case.

*** Air velocity measured 1 hour after defrost at the top discharge air duct using an ALNOR JR. velometer with a scoop.

**** This is an average refrigeration charge per foot based on R22 and R404A refrigerant usage.

FOR SPECIFIC COMPRESSOR SIZING INFORMATION, REFER TO TYLER APPLICATIONS FOR RACK SYSTEM COMPRESSORS AND/OR THE COMPRESSOR MANUFACTURERS FOR SINGLE COMPRESSORS. FOR LINE SIZING INFORMATION, REFER TO THE MISCELLANEOUS SECTION "BUFF" IN THE TYLER SPECIFICATION GUIDE.

Electrical Data:

Fans and Heaters (120 and 208 Volt)

MODEL	CASE LENGTH	FANS / CASE	TOTAL STANDARD FANS		TOTAL ECM FANS		TOTAL ANTI-SWEATS (120V)		208 VOLT DEFROST HEATER	
			AMPS	WATTS	AMPS	WATTS	DISCHARGE AIR AMPS	WATTS	AMPS	WATTS
N6DNL	4'	1	0.53	48.0	0.32	17.0	N/A	N/A	4.50	935.0
N6DN(L/M/H)	6'	2	1.06	96.0	0.64	34.0	N/A	N/A	4.70	975.0
N6DN(L/M/H)	8'	2	1.06	96.0	0.64	34.0	N/A	N/A	6.90	1,430.0
N6DN(L/M/H)	12'	3	1.59	144.0	0.96	51.0	N/A	N/A	10.30	2,145.0

* Discharge air anti-sweat heater will only be on when the canopy lights are off. Use highest amp draw of the two circuits to figure electrical case requirements.

Heaters (208 Volt)

FT	208 VOLT DEFROST (AMPS)												
	4	6	8	12	16	20	24	28	32	36	40	44	48
1 PH	4.5 TG-30	4.7 TG-30	6.9 TG-30	10.3 TG-30	13.8 TG-30	17.2 TG-30	20.6 TG-30	24.1 TG-30	27.5 TG-30	30.9 TG-30	34.4 TG-50	37.8 TG-50	41.2 TG-50
3 PH	N/A	N/A	N/A	N/A	12.0 TG-3-30	15.0 TG-3-30	18.0 TG-3-30	15.0 TG-3-30	18.0 TG-3-30	18.0 TG-3-30	21.0 TG-3-30	25.0 TG-3-40	28.0 TG-3-40

T-8 Lighting with Electronic Ballasts (120 Volt)

MODEL	CASE LENGTH	CANOPY LIGHTS* (2-ROWS)		SHELF LIGHTS - PER ROW										NOSE LIGHT		MAX. LIGHTING (8 ROWS)	
		AMPS	WATTS	AMPS					WATTS					AMPS	WATTS	AMPS	WATTS
				1	2	3	4	5	1	2	3	4	5				
N6DN	4'	0.50	60	0.45	0.60	0.80	0.95	1.30	54	72	96	114	156	0.35	42	2.15	258
N6DN	6'	0.75	90	0.60	0.90	1.20	1.50	1.90	72	108	144	180	228	0.40	48	3.05	366
N6DN	8'	0.95	114	0.90	1.20	1.60	1.90	2.40	108	144	192	228	288	0.50	60	3.85	462
N6DN	12'	1.40	168	1.35	1.80	2.40	2.85	3.55	162	216	288	342	426	0.70	84	5.65	678

* Standard lighting for this case is 2 rows of T-8 canopy lights.

Defrost Data:

DEFROST TYPE*	DEFROSTS PER DAY	DURATION TIME (MIN)	TERMINATION (°F)	EPR SETTINGS **		DEFROST WATER (LB / FT / DAY)
				R22 (PSIG)	R404A (PSIG)	
TIME OFF	6	18	- - -			
ELECTRIC	6	18	41	44	57	1.3
HOT GAS	6	15	55*			

* If an Electronic Sensor is used for termination, it should be set at 70°F termination temperature. The sensor must be located in the same location as the defrost termination klixon for that defrost type.

** Set EPR to give this pressure at the case.

DEFROST CIRCUITS: OFF CYCLE defrost is standard (use TC defrost module) – OPTIONAL ELECTRIC defrost uses a single or 3 phase 208V circuit – OPTIONAL HOT GAS defrost uses 2 control wires.

UL SANITATION approved in accordance with ANSI/NSF - 7.

CASE BTUH REQUIREMENTS are calculated to produce approximately the indicated entering-air temperature with absolute maximum operating ambient limits of **75°F & 55RH**.

The information contained herein is based on technical analysis and/or tests performed in a controlled lab environment that are consistent with industry practices, and is intended as a reference for system sizing and configuration purposes only and for use by persons having technical skill at their own discretion and risk. Conditions of use are outside of Tyler's control and we do not assume and hereby disclaim any liability for results obtained or damages incurred through application of or reliance on the data presented, including but not limited to specific energy consumption with any particular model or installed application. SPECIFICATIONS ARE SUBJECT TO CHANGE WITHOUT NOTICE.

CASE-TO-CASE SUCTION LINE SUB-FEED BRANCH LINE SIZING																
MODEL	4'	6'	8'	10'	12'	16'	20'	24'	28'	32'	36'	40'	44'	48'	52'	56'
N6DN R22	7/8"	7/8"	7/8"	7/8"	7/8"	7/8"	1 1/8"	1 1/8"	1 1/8"	1 3/8"	1 3/8"	1 3/8"	1 3/8"	1 3/8"	1 3/8"	1 3/8"

SHELVING NOTES: Shelving widths available for these cases are 15", 18" and 20". When two sizes are used, the smaller must be used on top.

N6DN CROSS SECTION

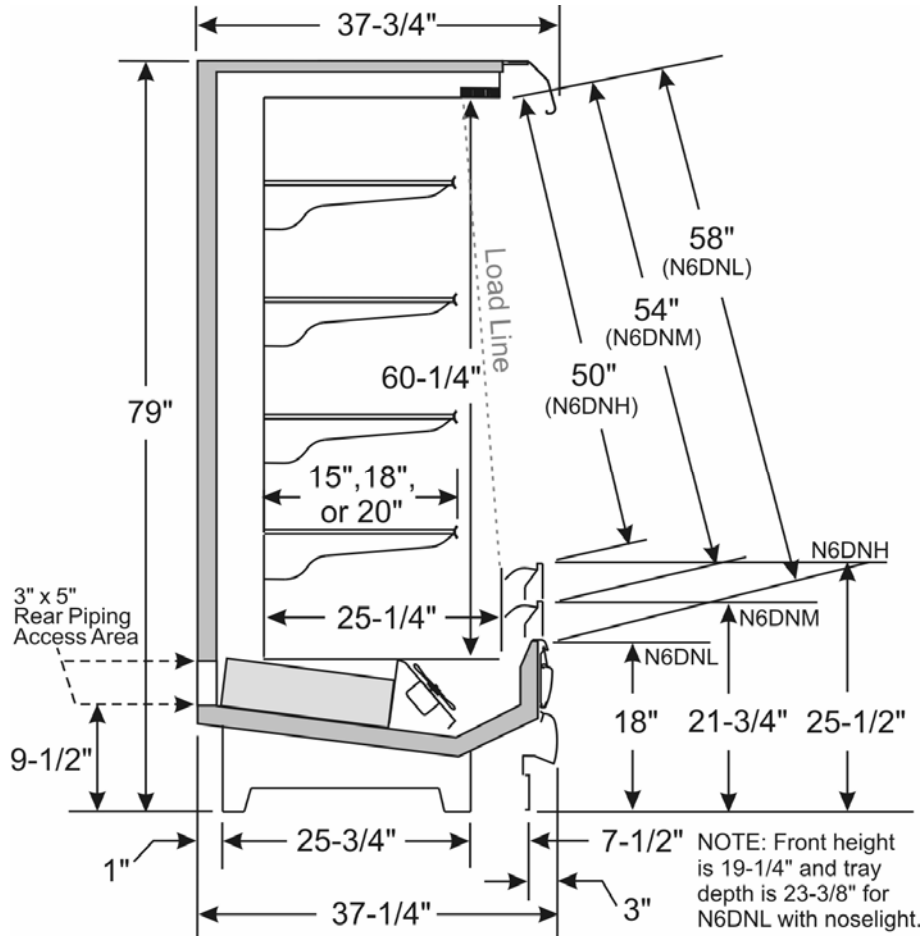

N6DN FLOOR PLAN

