

## SPECIFICATION SHEET

### • N7DNHPL HIGH PERF. EXT. HEIGHT NARROW MULTISHELF MED TEMP MERCHANDISERS •

**Refrigeration Data:**

MODEL	CASE LENGTH	CASE USAGE	CAPACITY (BTUH / FT)		EVAPORATOR (°F)	UNIT SIZING (°F)	DISCHARGE AIR		AVG. REF. CHARGE (LBS/FT)
			PARALLEL	CONVENTIONAL			TEMPERATURE (°F)	VELOCITY (FPM)	
N7DNHPL	8'/12'	MED TEMP	1,426*	1,458*	+28**	+26	34	260***	0.55****

\* Capacity data listed for cases with 2 rows of T-8 canopy lights, 1 row of nose lights and 5 rows of 18" unlighted shelves. Adjustments must be made to this base rating for each option installed on this case. DEDUCT 20 BTUH/FT if nose light is not used. NOTE: Contact TYLER for Peg Bar or Produce Insert Capacity Adjustments. For sizing all refrigeration equipment other than TYLER, use conventional BTUH values.

\*\* Evaporator temperature is based on the saturated pressure leaving the case.

\*\*\* Air velocity measured 1 hour after defrost at the top discharge air duct using an ALNOR JR. velometer with a scoop.

\*\*\*\* This is an average refrigeration charge per foot based on R22 and R404A refrigerant usage.

FOR SPECIFIC COMPRESSOR SIZING INFORMATION, REFER TO TYLER APPLICATIONS FOR RACK SYSTEM COMPRESSORS AND/OR THE COMPRESSOR MANUFACTURERS FOR SINGLE COMPRESSORS. FOR LINE SIZING INFORMATION, REFER TO THE MISCELLANEOUS SECTION "BUFF" IN THE TYLER SPECIFICATION GUIDE.

**Electrical Data:**

Fans and Heaters (120 and 208 Volt)

MODEL	CASE LENGTH	FANS / CASE	TOTAL STANDARD FANS		TOTAL ECM FANS		TOTAL ANTI-SWEATS (120V)	
			AMPS	WATTS	AMPS	WATTS	AMPS	WATTS
N7DNHPL	8'	2	0.72	84.0	0.64	34.0	N/A	N/A
N7DNHPL	12'	3	1.08	126.0	0.96	51.0	N/A	N/A

T-8 Lighting with Electronic Ballasts (120 Volt)

MODEL	CASE LENGTH	CANOPY LIGHTS* (2-ROWS)		SHELF LIGHTS - PER ROW												NOSE LIGHT		MAX. LIGHTING (3 ROWS)		
		AMPS	WATTS	AMPS						WATTS						AMPS	WATTS	AMPS	WATTS	
				1	2	3	4	5	6	1	2	3	4	5	6					
N7DNHPL	8'	0.95	114	N/A	N/A	N/A	N/A	N/A	N/A	N/A	N/A	N/A	N/A	N/A	N/A	N/A	0.50	60	1.45	174
N7DNHPL	12'	1.40	168	N/A	N/A	N/A	N/A	N/A	N/A	N/A	N/A	N/A	N/A	N/A	N/A	N/A	0.70	84	2.10	252

\* Standard lighting for this case is 2 rows of T-8 canopy lights.

**Defrost Data:**

DEFROST TYPE*	DEFROSTS PER DAY	DURATION TIME (MIN)**	ELEK. THERMOSTAT / AIR SENSOR SETTINGS			EPR SETTINGS ***		CONVENTIONAL COMPRESSOR SETTINGS ****				DEFROST WATER (LB / FT / DAY)	
			USAGE	CUT-IN	CUT-OUT	R22 (PSIG)	R404A (PSIG)	R22 (PSIG)		R404A (PSIG)			
TIME OFF	4	8	FRONT LOAD - ALL APPLICATIONS	34	32	52	67	50	36	64	47	9.2 (max.)	

\* All high performance cases use OFF CYCLE defrost.

\*\* NOTE: 8 minutes is for EPR with suction stop for defrost isolation. Defrost times increases by four minutes when defrost isolation is by pump down.

\*\*\* If EPR is utilized, use the settings shown in the chart. ADD 0.5# to EPR setting for each 1,000 foot rise in elevation.

\*\*\*\* Recommended setup for a conventional unit uses an electronic thermostat to assure accurate temperature control.

**Case control is recommended using EPR only.**

CASE-TO-CASE SUCTION LINE SUB-FEED BRANCH LINE SIZING													
MODEL	8'	12'	16'	20'	24'	28'	32'	36'	40'	44'	48'	52'	56'
N7DNHPL - R22	5/8"	7/8"	7/8"	7/8"	1-1/8"	1-1/8"	1-1/8"	1-1/8"	1-1/8"	1-3/8"	1-3/8"	1-3/8"	1-3/8"

**SHELVING NOTES:** Shelving widths available for these cases are 12", 15", 16", 18" and 20". When two sizes are used, the smaller must be used on top.

**UL SANITATION** approved in accordance with ANSI/NSF - 7.

**CASE BTUH REQUIREMENTS** are calculated to produce approximately the indicated entering-air temperature with absolute maximum operating ambient limits of **75°F & 55RH**.

The information contained herein is based on technical analysis and/or tests performed in a controlled lab environment that are consistent with industry practices, and is intended as a reference for system sizing and configuration purposes only and for use by persons having technical skill at their own discretion and risk. Conditions of use are outside of Tyler's control and we do not assume and hereby disclaim any liability for results obtained or damages incurred through application of or reliance on the data presented, including but not limited to specific energy consumption with any particular model or installed application. SPECIFICATIONS ARE SUBJECT TO CHANGE WITHOUT NOTICE.

**N7DNHPL CROSS SECTION**

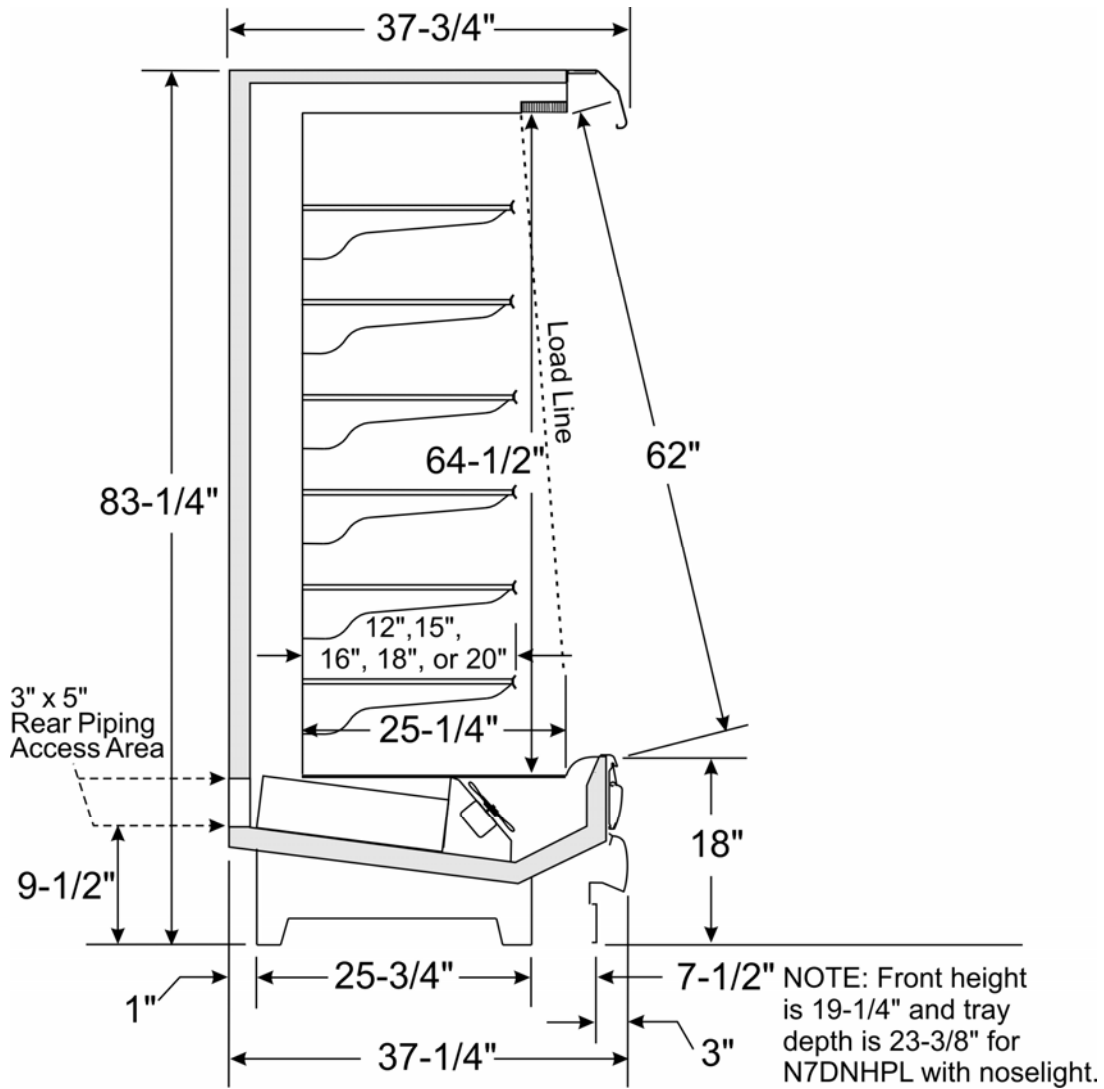

**N7DNHPL FLOOR PLAN**

