

NLF Lift Curved Glass



NLF seafood service merchandisers provide gravity coil cooling that keeps seafood products fresh. The front-lift curved glass is designed to maximize product viewing, while the glass lift system allows easy front access for stocking and merchandising of fresh seafood products.

Features & Benefits

- ♦ Energy-efficient copper tube and aluminum fin coils.
- ♦ Single row of T8 top lights for increased product illumination.
- ♦ Patented counter-weighted mechanical hinges allow easy lifting of front glass.
- ♦ 22-1/2" clear sliding rear doors for easy access to interior.
- ♦ Easily removable interior components for quicker cleaning.
- ♦ Pipe leg base and removable kickplate facilitate cleaning under the case.
- ♦ Ice trays keep seafood fresh and enhance product presentation.
- ♦ Off-cycle defrost.

Options

- ♦ Glass windows on patch end panels.
- ♦ Scale shelves.

Specifications are subject to engineering changes without notice.

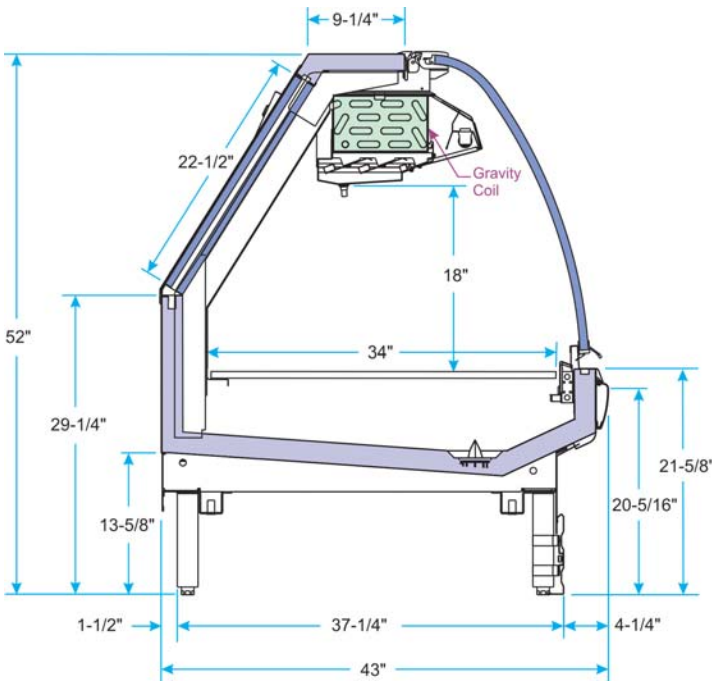

Model	Case Length	Description	Capacity in Cubic Feet
NLF	4' • 6' • 8' • 12'	Lift Curved Front Glass with std top gravity coil	14.6 • 21.9 • 29.3 • 43.8

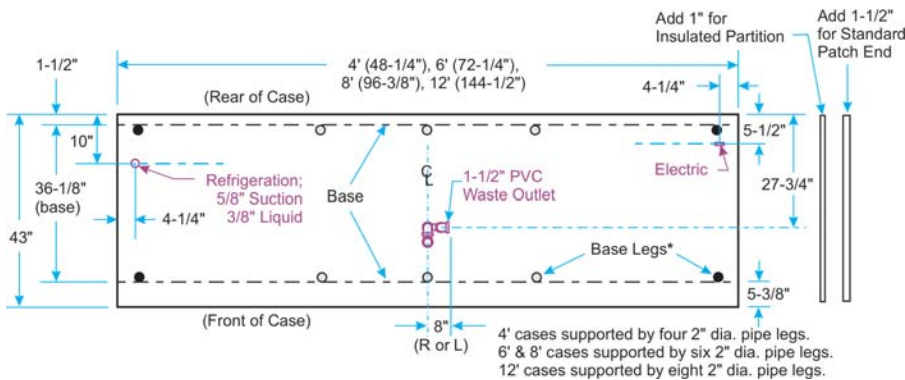

Optional Accessories

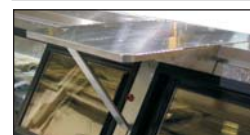

Scale Shelves add more functionality to the work area.

Meat / Seafood