

NLM meat service merchandisers provide optimum dual-coil cooling to ensure product integrity. The front-lift curved glass is designed to maximize product viewing, while the glass lift system allows easy front access for stocking and merchandising of fresh meat products.



**Features & Benefits**

- ♦ Energy-efficient copper tube and aluminum fin coils.
- ♦ Single row of T8 top lights for increased product illumination.
- ♦ Patented counter-weighted mechanical hinges allow easy lifting of front glass.
- ♦ 22-1/2" clear sliding rear doors for easy access to interior.
- ♦ Easily removable interior components for quicker cleaning.
- ♦ Pipe leg base and removable kickplate facilitate cleaning under the case.
- ♦ Off-cycle defrost.

**Options**

- ♦ Glass windows on patch end panels.
- ♦ White powder-coated display screens.
- ♦ Step trays and food pans.
- ♦ Scale shelves.

Specifications are subject to engineering changes without notice.

Model	Case Length	Description	Capacity in Cubic Feet
NLM	6' • 8' • 12'	Lift Curved Front Glass with std gravity & serpentine coils	21.9 • 29.3 • 43.8

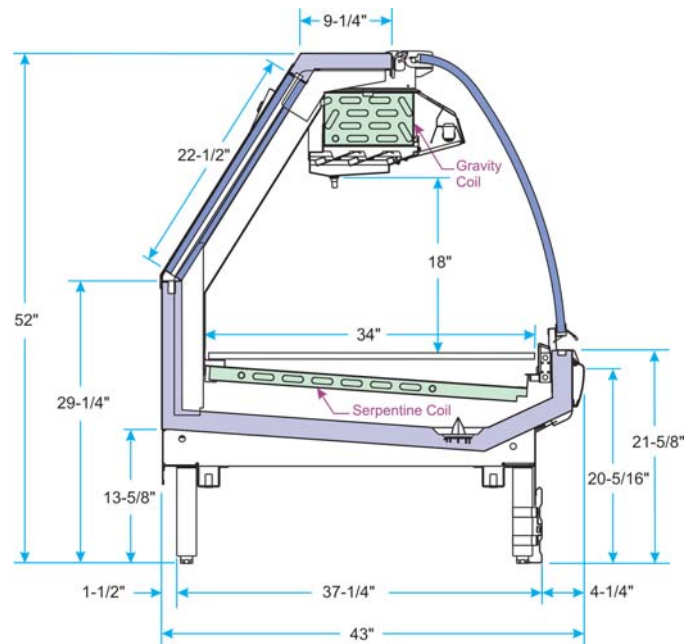

**Optional Accessories**



Scale Shelves add more functionality to the work area.

