

SPECIFICATION SHEET

• NP TOP DISPLAY BULK PRODUCE MERCHANDISERS •

Refrigeration Data:

MODEL	CASE LENGTH	CASE USAGE	CAPACITY (BTUH / FT)		EVAPORATOR (°F)	UNIT SIZING (°F)	DISCHARGE AIR		AVG. REF. CHARGE (LBS/FT)
			PARALLEL	CONVENTIONAL			TEMPERATURE (°F)	VELOCITY (FPM)	
NP	8'/12'	BULK PRODUCE	354*	386*	+20**	+18	+34	215***	0.25

* For sizing all refrigeration equipment other than TYLER, use conventional BTUH values.

** Evaporator temperature is defined as the saturated pressure leaving the case.

*** Air velocity measured 1 hour after defrost at the discharge air duct using an ALNOR JR. velometer with a scoop.

Use the NM cases for critical temp applications.

FOR SPECIFIC COMPRESSOR SIZING INFORMATION, REFER TO TYLER APPLICATIONS FOR RACK SYSTEM COMPRESSORS AND/OR THE COMPRESSOR MANUFACTURERS FOR SINGLE COMPRESSORS. FOR LINE SIZING INFORMATION, REFER TO THE MISCELLANEOUS SECTION "BUFF" IN THE TYLER SPECIFICATION GUIDE.

Electrical Data:

Fans (120 Volt)

MODEL	CASE LENGTH	FANS / CASE	TOTAL STANDARD FANS		TOTAL ECM FANS	
			AMPS	WATTS	AMPS	WATTS
NP	8'	2	0.68	60.4	0.44	22.0
NP	12'	3	1.02	90.6	0.66	33.0

Defrost Data:

DEFROST TYPE	DEFROSTS PER DAY	DURATION TIME (MIN)	TERMINATION (°F)	EPR SETTINGS *		DEFROST WATER (LB / FT / DAY)
				R22 (PSIG)	R404A (PSIG)	
TIME OFF	3-4	40	---	43	56	N/A

* Set EPR to give this pressure at the case.

CASE-TO-CASE SUCTION LINE SUB-FEED BRANCH LINE SIZING														
MODEL	8'	12'	16'	20'	24'	28'	32'	36'	40'	44'	48'	52'	56'	60'
NP R22	1/2"	1/2"	1/2"	5/8"	5/8"	5/8"	7/8"	7/8"	7/8"	7/8"	7/8"	7/8"	7/8"	7/8"

UL SANITATION approved in accordance with ANSI/NSF - 7.

CASE BTUH REQUIREMENTS are calculated to produce approximately the indicated entering-air temperature with absolute maximum operating ambient limits of **75°F & 55RH**.

The information contained herein is based on technical analysis and/or tests performed in a controlled lab environment that are consistent with industry practices, and is intended as a reference for system sizing and configuration purposes only and for use by persons having technical skill at their own discretion and risk. Conditions of use are outside of Tyler's control and we do not assume and hereby disclaim any liability for results obtained or damages incurred through application of or reliance on the data presented, including but not limited to specific energy consumption with any particular model or installed application. SPECIFICATIONS ARE SUBJECT TO CHANGE WITHOUT NOTICE.

NP CROSS SECTION

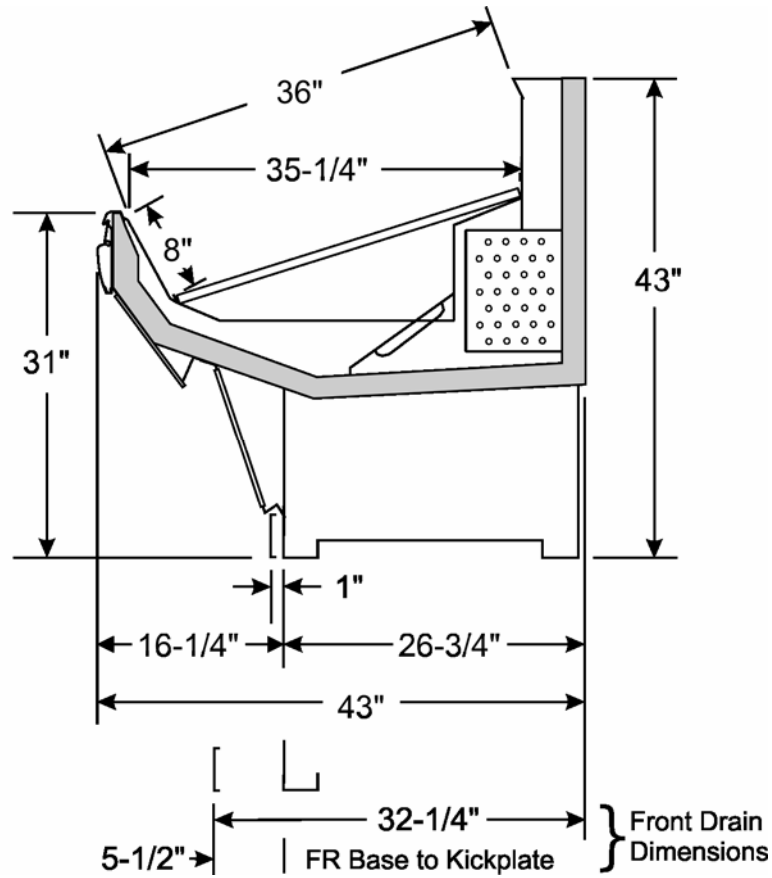

FLOOR PLAN

