

TYLER

Allegro
S E R I E S™

Installation & Service Manual

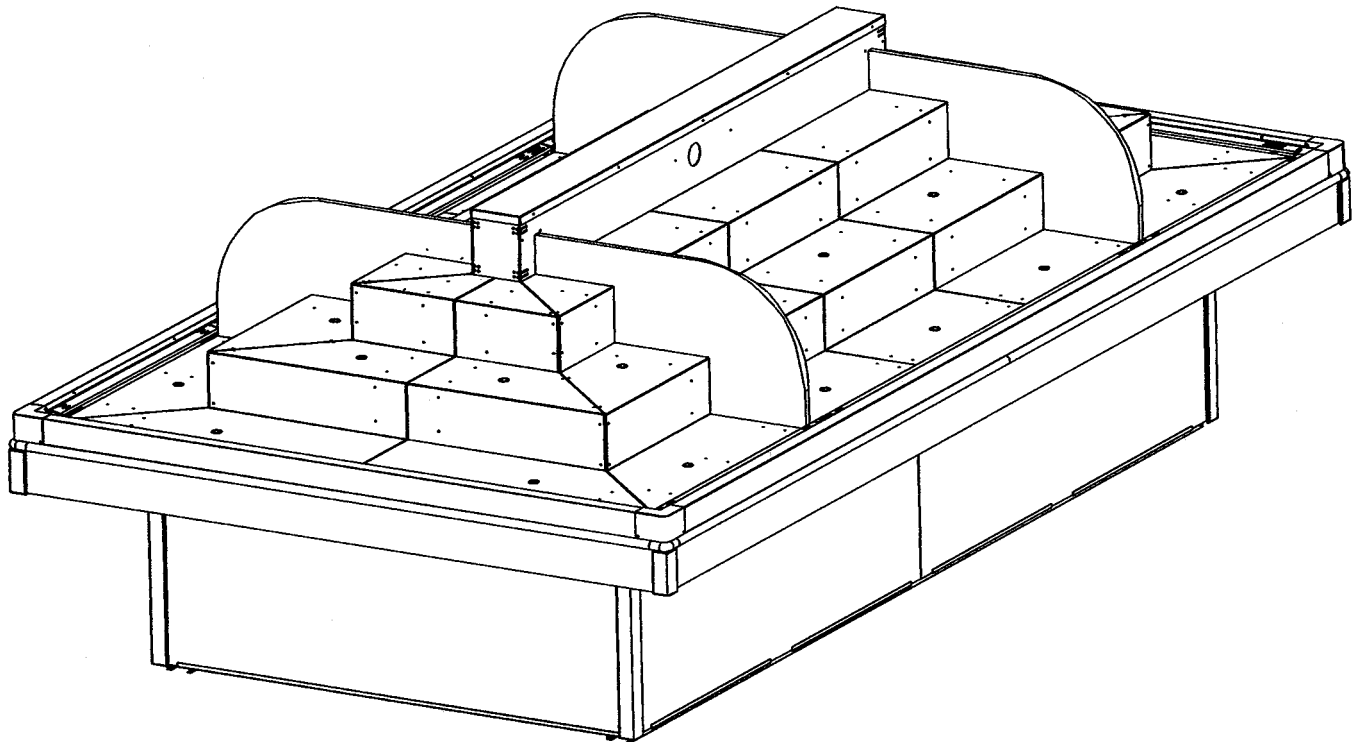

NRPIE, NRPIEE

BULK PRODUCE & CHEESE ISLAND MERCHANDISERS
Medium Temperature Self-Serve Display Cases

This manual has been designed to be used in conjunction with the
General (UL/NSF) Installation & Service Manual.

Save the Instructions in Both Manuals for Future Reference!!

This merchandiser conforms to the American National Standard Institute & NSF International Health and Sanitation standard ANSI/NSF 7 - 2003.

PRINTED IN U.S.A.	Specifications subject to change without notice.	REPLACES EDITION	ISSUE DATE	2/05	PART NO.	9808263	REV.
-------------------	--	------------------	------------	------	----------	---------	------

CONTENTS

	<u>Page</u>
Specifications	
NRPIE, NRPIEE Specification Sheets	4
Line Sizing Requirements (See General-UL/NSF I&S Manual)	
Pre-Installation Responsibilities (See General-UL/NSF I&S Manual)	
Installation Procedures	
Carpentry Procedures	6
Case Pull-Up Locations	6
Trim Installation/Alignment (See General-UL/NSF I&S Manual)	
Plumbing Procedures (See General-UL/NSF I&S Manual)	
Refrigeration Procedures (See General-UL/NSF I&S Manual)	
Electrical Procedures	6
Electrical Considerations	6
Defrost Information	6
Defrost Control Chart	6
Installation Procedure Check Lists (See General-UL/NSF I&S Man.)	
Wiring Diagrams	7
NRPIE/NRPIEE Domestic & Export (50Hz) Case Circuits	7
Cleaning and Sanitation (See General-UL/NSF I&S Manual)	
Component Removal and Installation Instructions for Cleaning . . .	8
Optional Step Shelves	8
Screens	8
Bottom Trays	8
Perimeter Air Ducts	8
NSF Product Thermometer	8
Rear and End Duct Panels	8
Perimeter Cladding	8
Base Side and Base End Panels	8
General Information	
NSF Product Thermometer Installation	9
Water Spray Accessories	10
Produce Handling Tips	11
Produce Handling Chart	11

	<u>Page</u>
Service Instructions	
Preventive Maintenance (See General-UL/NSF I&S Manual)	
Bumper Replacement	12
Corner Trim Replacement	12
Fan Blade and Motor Replacement	12
Parts Information	
Cladding and Optional Trim Parts Lists	14
Operational Parts List	16
TYLER Warranty (See General-UL/NSF I&S Manual)	

The following Medium Temperature Bulk Produce and Cheese Island Merchandiser models are covered in this manual:

MODEL	DESCRIPTION
NRPIE	8' & 12' REFRIGERATED BULK PRODUCE/CHEESE ISLAND MERCHANDISERS WITH ONE SHOP-AROUND END
NRPIEE	8', 12' REFRIGERATED BULK PRODUCE/CHEESE ISLAND MERCHANDISERS WITH TWO SHOP-AROUND ENDS (NOTE: 16', 20' & 24' ISLANDS CAN BE MADE BY USING COMBINATIONS OF 8' & 12' NRPI MODELS.)

SPECIFICATIONS

NRPIE/NRPIEE Bulk Produce & Cheese Island Merchandisers

Refrigeration Data:

MODEL	CASE LENGTH	CASE USAGE	CAPACITY (BTUH / FT)		EVAPORATOR (°F)	UNIT SIZING (°F)	DISCHARGE AIR		AVG. REF. CHARGE (LBS/FT)
			PARALLEL	CONVENTIONAL			TEMPERATURE (°F)	VELOCITY (FPM)	
NRPIE	8'/12'	BULK PROD.	2,163*	2,557*	+20**	+18	+35	N/A***	0.40****
NRPIEE	8'/12'	BULK PROD.	2,813*	2,935*	+20**	+18	+35	N/A***	0.40****

* For sizing all refrigeration equipment other than TYLER, use conventional BTUH values.
 ** Evaporator temperature is defined as the saturated pressure leaving the case.
 *** Air velocity measured 1 hour after defrost at the center riser discharge air duct using an ALNOR JR. velometer with a scoop.
 **** This is an average refrigeration charge per foot based on R22 and R404A refrigerant usage.

These island produce cases are not designed for critical temp applications.

FOR SPECIFIC COMPRESSOR SIZING AND/OR LINE SIZING INFORMATION, REFER TO THE "GOLD" AND/OR "BUFF" SECTIONS IN THE TYLER SPECIFICATION GUIDE.

Electrical Data:

Fans and Heaters (120 Volt)

MODEL	CASE LENGTH	FANS / CASE	TOTAL STANDARD FANS		TOTAL ECM FANS		TOTAL ANTI-SWEATS (120V)	
			AMPS	WATTS	AMPS	WATTS	DISCHARGE AIR	
							AMPS	WATTS
NRPIE	8'	2	0.68	60.4	0.44	22.0	N/A	N/A
NRPIE	12'	3	1.02	90.6	0.66	33.0	N/A	N/A
NRPIEE	8'	3	1.02	90.6	0.66	33.0	N/A	N/A
NRPIEE	12'	3	1.02	90.6	0.66	33.0	N/A	N/A

Defrost Data:

DEFROST TYPE*	DEFROSTS PER DAY	DURATION TIME (MIN)	TERMINATION (°F)	EPR SETTINGS *		DEFROST WATER (LB / FT / DAY)	
				R22 (PSIG)	R404A (PSIG)	NRPIE	NRPIEE
TIME OFF	1	60	- - -	43	56	N/A	N/A

Set EPR to give this pressure at the case.

CASE-TO-CASE SUCTION LINE SUB-FEED BRANCH LINE SIZING									
MODEL	8'	10'	12'	14'	16'	18'	20'	22'	24'
NRPIE	5/8"	N/A	5/8"	N/A	N/A	N/A	N/A	N/A	N/A
NRPIEE	5/8"	N/A	7/8"	N/A	7/8"	N/A	7/8"	N/A	7/8"

UL SANITATION approved in accordance with ANSI/NSF – 7.

CASE BTUH REQUIREMENTS are calculated to produce approximately the indicated entering-air temperature with absolute maximum operating ambient limits of 75°F & 55RH

The information contained herein is based on technical data and tests that we believe are reliable, and is intended for use by persons having technical skill at their own discretion and risk. Since conditions of use are outside of Tyler's control, we cannot assume any liability for results obtained or damages incurred through the applications of the data presented. SPECIFICATIONS ARE SUBJECT TO CHANGE WITHOUT NOTICE.

NRPIE/NRPIEE CROSS SECTION

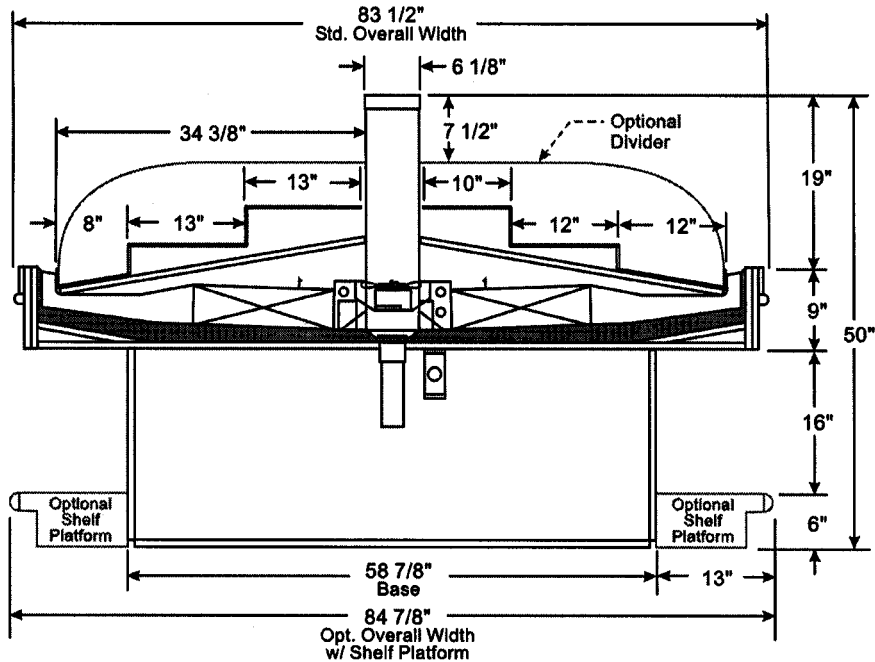

NRPIEE 8/12 FLOOR PLAN

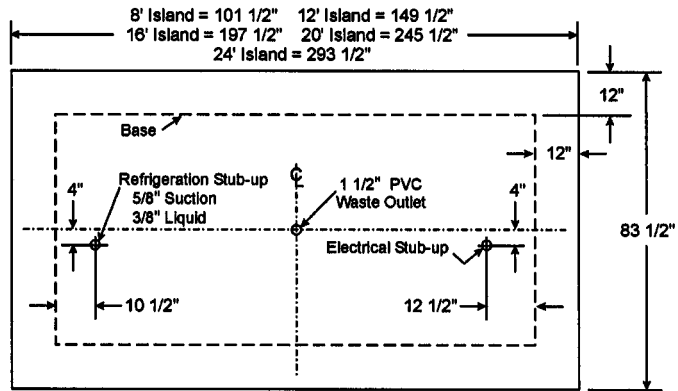

NRPIE 8/12 FLOOR PLAN

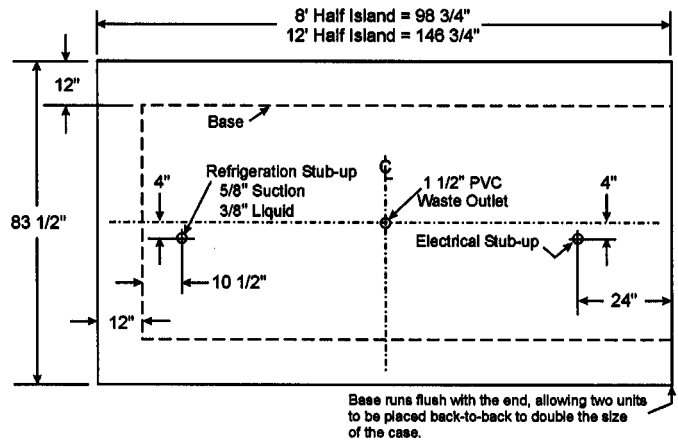

INSTALLATION PROCEDURES

Carpentry Procedures

Case Pull-Up Locations

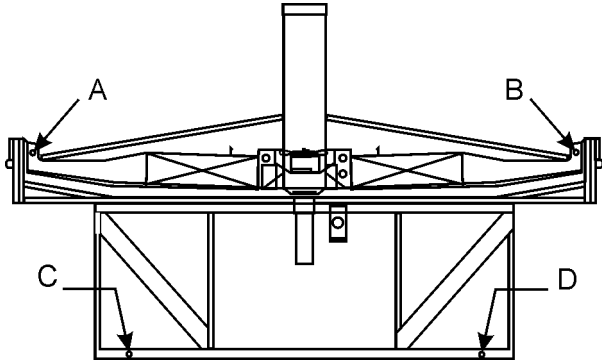

The NRPIEE models do not have any open ends, therefore no pull-ups are required. The NRPIE models have four pull-ups at each open end of the case. Pull-ups A, B, C and D are located as shown and used for joining end cases. All pull-ups should be installed and tightened starting with A and finishing with D.

See "General-UL/NSF I&S Manual" for line-up assembly and color band & bumper installation instructions.

After all case pull-ups have been secured, install the bottom trays and the case screens.

Electrical Procedures

Electrical Considerations

CAUTION

Make sure all electrical connections at components and terminal blocks are tight. This prevents burning of electrical terminals and/or premature component failure.

Case Fan Circuit

This circuit is to be supplied by an uninterrupted, protected 120V circuit. The case fan circuit is not cycled.

Defrost Information

See "General-UL/NSF I&S Manual" for operational descriptions for each type of defrost control.

Defrost Control Chart

Defrost Type	Defrosts Per Day	Defrost	
		Duration (Min)	Term. Temp.
Off Time	1	60	-----

WIRING DIAGRAMS

**ELECTRICIAN NOTE -
OVERCURRENT PROTECTION**

120V circuits should be protected by 15 or 20 Amp devices per the requirements noted on the cabinet nameplate or the National Electrical Code, Canadian Electrical Code - Part 1, Section 28. 208V defrost circuits employ No. 12 AWG field wire leads for field connections. On remote cases intended for end to end line-ups, bonding for ground may rely upon the pull-up bolts.

The following wiring diagram on page 7 covers all the NRPIE and NRPIEE case circuits.

NRPIE/ NRPIEE Domestic & Export (50Hz) Case Circuits (8' & 12' Island Cases)



1. TYLER REFRIGERATION CORP. CLAIMS RIGHTS TO THE INFORMATION ON THIS DRAWING.
 2. INFORMATION IS FOR ENGINEERING USE ONLY AND MAY NOT BE USED WITHOUT PERMISSION.
 3. DIMENSIONS ARE IN INCHES UNLESS SPECIFIED OTHERWISE.
 4. DIMENSIONS APPLY TO FINISHED PART AFTER ANY TREATMENT.
 5. NO MANUAL REVISIONS ALLOWED.

PART TYPE	N	T	S
MODEL	X		
FABRICATED	X		
PURCHASED			
DEPT	CC	W	

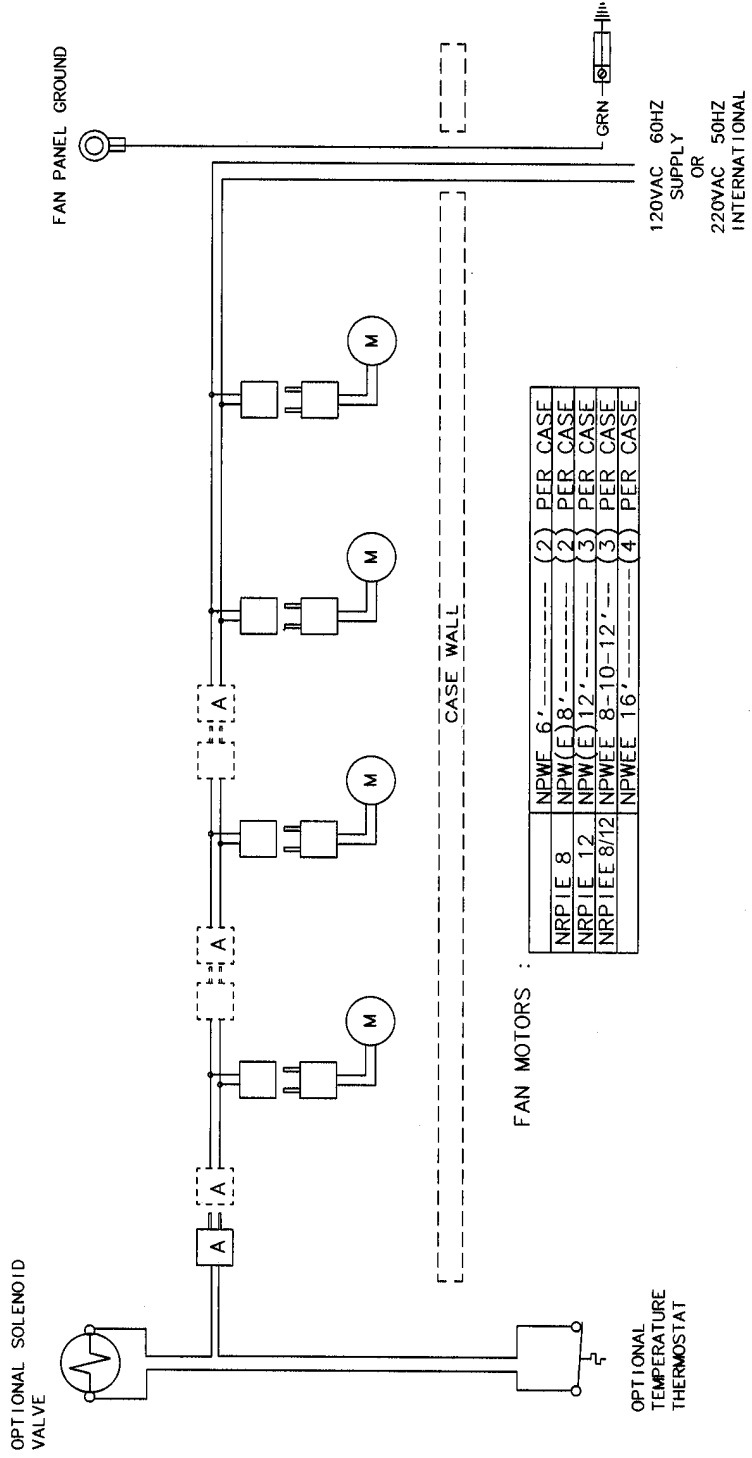

NRPIE 8	NPWE 6'	(2)	PER CASE
NRPIE 12	NPWE 8'	(2)	PER CASE
NRPIEE 8/12	NPWE 12'	(3)	PER CASE
	NPWE 8-10-12'	(3)	PER CASE
	NPWE 16'	(4)	PER CASE

NOTE : ALL CASES MUST BE GROUNDED

DECIMALS +/-	.030	ANGLES +/-	1	DEG
NAME	DIAGRAM WRG NRPI_NPW(E)(EE)			
DATE	16OCT96	LC	CK	
RELEASE	40349	16SEP04	LC	JL
DESCRIPTION	REVISED BORDER AND NAME			
REV	B	96-104	9028467	B

CLEANING AND SANITATION

Component Removal and Installation Instructions for Cleaning

Product Dividers and Product Stops

1. Remove product dividers and or product stops by lifting up and out to remove them from the case.
2. After cleaning, replace them in the same location they were removed from.

Optional Step Shelves

1. Remove product from step shelves.
2. Remove product dividers, see this page.
3. Push step shelf up until bottom front edge of step shelf clears the front duct.
4. Remove step shelf from holes in rear duct panels and from case.
5. After cleaning, replace step shelf assembly in reverse order.

Screens

1. Remove product from screens.
2. Push screens up until bottom screen tabs clear the holes in the front duct.
3. Remove screens from holes in rear duct panels and from case.
4. After cleaning, replace in reverse order.

Bottom Trays

1. Remove product and screens from case. See this page.
2. Grasp and lift out each of the bottom trays from the case interior.
3. After cleaning, replace in reverse order.

Perimeter Air Ducts

1. Remove screens and bottom trays, see this page.
2. Lift out perimeter air duct sections and carefully remove from case.
3. After cleaning, replace in reverse order.

NSF Product Thermometer

Remove two screws and product thermometer/bracket assembly from end left side perimeter air duct section. After cleaning, replace product thermometer/bracket assembly and secure with two screws.

NOTE

The product thermometer must always be located at the end on the left side of the case.

Rear and End Discharge Duct Panels

1. Remove product, screens and bottom trays, see this page.

Perimeter Upper Cladding

1. Remove all mounting screws and upper corner trims from corners of the case.
2. Remove bumper and bumper corner trim from case. See page 12.
3. Remove mounting screws, bumper retainers and upper side and end cladding from case.
4. After cleaning, replace in reverse order.

Base Side and Base End Panels

1. Remove all mounting screws, lower base joint trim and lower base corner trims from case.
2. Remove all mounting screws and base side panels from sides of case.
3. Remove all mounting screws and base end panels from case ends.
4. After cleaning, replace in reverse order.

GENERAL INFORMATION

NSF Product Thermometer Installation

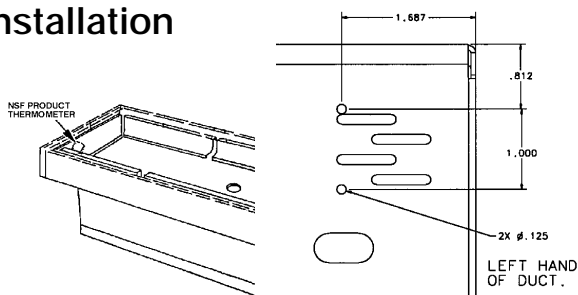

1. Remove end perimeter air duct section from left side of case.
2. Measure and mark removed air duct section as shown.
3. Drill two .125" holes at marked locations.
4. Install product thermometer/bracket assembly on air duct section with two screws.

Water Spray Accessories

WARNING

When using water spray accessories it may be necessary to install approved anti-backflow devices in the water supply line. Local codes should be checked in this regards. Installation of this device is the responsibility of the end user and would be performed by plumbers.

CAUTION

Do not spray lighted shelves when using any water spray accessories. Moisture on light fixtures could cause an electrical short and/or damage the case operating system.

The water supply pressure should not exceed 45 lb to assure proper operation. Water supply pressures above 45 lb should use a pressure reducing valve.

The spring coil spray hose or retractable spray hose are the two manual systems available for produce cases. To use the retractable spray hose, pull the nozzle and hose out smoothly to the desired length. When the reel ratchet sounds, let the hose back against the ratchet to hold it in place. To rewind, pull hose out slightly to release the

reel ratchet, then guide the hose back into the front of the case. Do not allow hose to rewind by itself. Hose jamming and/or reel damage could result.

Retractable Hose Replacement

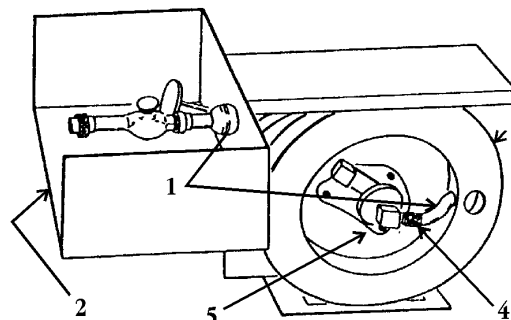

1. Pull hose (1) completely out of front of case (2) and engage reel ratchet.
2. Fasten locking pliers on the reel edge (3) to prevent the reel from accidentally rewinding. The reel spring is fully wound in this position.
3. Remove hose (1) from hose clamps on the reel (3) and disconnect hose end fitting (4) from swivel assembly (5). Remove hose (1) from reel (3) and front of case (2).

CAUTION

Do not allow the reel to unwind suddenly or attempt to turn reel clockwise. This will damage the spring motor in the reel.

NOTE

If reel spring is unwound, wind the reel 19 complete turns counterclockwise, engage the reel ratchet and install locking pliers on reel edge.

4. Insert hose (1) through the front of the case (2) and the hole in the reel (3).
5. Apply pipe dope to threads of hose end fitting (4). Install hose end fitting (4) in the swivel assembly (5).
6. Attach the hose (1) securely to the reel (3) with the hose clamps on the reel.
7. Retract the hose (1) onto the reel (3).

NOTE

If reel does not work properly after rewinding, replace the reel assembly.

Produce Handling Tips

Fresh fruits and vegetable are living things, even after they have been harvested. They continue the process of respiration and transpiration after harvesting. Respiration is the process of self feeding to provide energy for maintaining life. (EXAMPLE: Asparagus and sweet corn generate heat after they are picked.) Transpiration is the process of water loss through vapor from the plant tissues. Post-harvest life can be maintained by slowing the rate of water loss. Refrigeration lowers the rate of respiration and transpiration. Store most types of produce close to freezing prior to display. There are a number of explanations (ex. Cucumbers can be kept relatively cool by themselves, but could be damaged by temperatures below 40°F). See chart on following pages for specifics.

Non-refrigerated produce cases are called "Dry" cases. They are used to display potatoes, dry onions, bananas, avocados and

other products which don't need refrigeration. These cases can also be used with a bed of cracked ice to display perishables.

Refrigerated produce cases displays produce products that require refrigeration. The refrigeration coil is below the display and fans are used to circulate air through the case display. This moving air will pick up moisture from unwrapped produce and carry it to the coil. It is necessary to replace this moisture by using a water spray several times during the day. At night the produce should be covered with a wet cloth. The alternate to sprinkling is to wrap the produce.

In order to maintain case air flow, the return air duct must not be blocked by product. An important aid to improve air circulation is to use air deflectors below the elevated screens in the case. These deflectors will direct the air flow into the display and prevent cool air from "short circuiting" the display. Deflectors are furnished with hump screen option. See illustration.

Produce Handling Chart

Produce	Ideal Storage Conditions			Display Rack Care		
	Temperature (°F)	Relative Humidity (%)	Sell Quickly (1-2 days)	Refrigerate (40°F)	Sprinkle with Water	Special Notes
Apples	30-32	85-95		Helpful	No advantage	Avoid bruising
Apricots	31-32	85-90	Yes	Helpful	No	
Asparagus	32-36	90-95	Yes	Profitable	No	Trim butts and stand in ice or shallow water
Avocados	40-55	85-90	Yes	No	No	Display on padded surface
Bananas, Ripe	56-58	85-90	Yes	No	No	Display on padded surface
For Ripening	58-68	90-95		No	No	Avoid bruising
Beans, Lima	32-40	85-90	Yes	Profitable	No	Shake up to aerate
Beans, Snap	40-45	90-95	Yes	Profitable	Yes	
Beets	32	85-95	Yes	Profitable	Yes	Moisten roots only
Berries	31-32	90-95	Yes	Helpful	No	Keep well ventilated
Broccoli	32-35	90-95	Yes	Profitable	Yes	Keep out of sun
Brussel Sprouts	32-35	90-95	Yes	Profitable	Yes	Remove yellow leaves
Cabbage	32	90-95		Helpful	Yes	
Carrots	32	90-95		Profitable	Yes	Moisten roots only of bunches
Cauliflower	32	90-95	Yes	Profitable	Yes	Sprinkle only if refrigerated
Celery	31-32	90-95	Yes	Profitable	Yes	

<u>Produce</u>	<u>Ideal Storage Conditions</u>			<u>Display Rack Care</u>		
	<u>Temperature (°F)</u>	<u>Relative Humidity (%)</u>	<u>Sell Quickly (1-2 days)</u>	<u>Refrigerate (40°F)</u>	<u>Sprinkle with Water</u>	<u>Special Notes</u>
Cherries	31-32	90-95	Yes	Helpful	No	Keep well ventilated
Corn, Sweet	31-32	90-95	Yes	Profitable	Yes	Keep cold to keep sweetness
Cucumbers	45-50	85-90	Yes	No	No advantage	
Eggplants	45-50	85-90	Yes	No	No advantage	Do not bruise, keep on ice
Grapefruit	50-60	85-90		Helpful	No advantage	Remove decayed fruit
Grapes	30-32	85-95	Yes	Helpful	No	Keep well ventilated
Honeydews	45-50	85-90		Helpful	No	Cover cut melons with transparent film
Lemons	38-40	85-90		Helpful	Yes	Sprinkling may be helpful
Lettuce	32	90-95	Yes	Profitable	Yes	Avoid soaking with water
Limes	48-50	85-90		Helpful	No advantage	
Mushrooms	32-35	80-90	Yes	Helpful	No	Handle carefully, keep dry
Muskmelons	32-35	85-90	Yes	Helpful	No	Cover cut melons with transparent film
Onions, Dry	32	65-70		No	No	Remove loose wrappers, keep dry
Onions, Green	32	90-95	Yes	Profitable	Yes	Keep well ventilated
Oranges	34-38	85-90		Helpful	No advantage	Remove decayed fruit
Parsnips	32	90-95		Helpful	Yes	Moisten roots only
Peaches, Ripe	31-32	90	Yes	Helpful	No	Ripen at room temperature before storage
Pears	29-31	90-95	Yes	Helpful	No	Display in single or double layer on pads
Peas, Green	32	90-95	Yes	Profitable	Yes	Shake up to aerate, keep cold
Peppers	45-50	90-95	Yes	Profitable	Yes	
Pineapples, Ripe	45-55	85-90	Yes	No	No	Remove decayed fruit
Plums	31-32	90-95	Yes	Helpful	No	Remove decayed fruit
Potatoes	40-50	85-90		No	No	Keep out of sun
Radishes	32	90-95	Yes	Profitable	Yes	Keep water off tops, avoid tight packing
Rhubarb	32	90-95	Yes	Profitable	No	Trim thin slice off stems and stand in cold water
Squash, Summer	40-50	85-95	Yes	Helpful	Yes	
Winter & Pmpkns	50-55	50-75		No	No	
Spinach	32	90-95	Yes	Profitable	Yes	Keep ventilated
Sweet Potatoes	55-60	85-90		No	No	Keep ventilated
Tangerines	32	85-90	Yes	Profitable	Yes	Remove decayed fruit
Tomatoes, Ripe	45-50	85-90	Yes	Helpful	No	Sell quickly, refrigerate to hold
Tomatoes, Green	55-70	85-90		No	No	Ripen in back room, sort frequently
Turnips	32	90-95		Profitable	Yes	Sprinkle roots only
Watermelons	40-45	80-85		Helpful	No	Cover cut melons with transparent film

The "Produce Handling Chart" is courtesy of Produce Marketing Association, Inc., Newark, Delaware 19711, from their 1973 Yearbook. This book is published as a service to the Fresh Produce Industry.

For additional information, consult:

"The Commercial Storage of Fruits, Vegetables, and Florist and Nursery Stocks", USDA Handbook No. 66, 1968.

"The Shelf Life of Fresh Fruits and Vegetables - Retail Store Display Cases", USDA HT&S Office Report No. 247, October 1951.

"Fresh Fruits and Vegetables - Handling and Care", Corporate Extension Service, Michigan State University.

SERVICE INSTRUCTIONS

Bumper Replacement

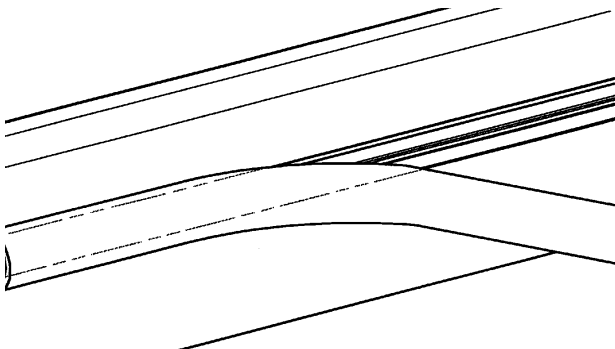

1. Starting at one of the bumper seams, pry edge of bumper until it starts to release from the bumper retainer track. Pull out the bumper end to remove bumper from the bumper retainer track.
2. Cut new bumper slightly longer (approx. 1/8" than the old bumper. Starting at either end of the bumper section being replaced, push bumper onto the bumper retainer track until it snaps in place. The additional 1/8" length will allow for normal shrinkage from case cooling.

NOTE

Bumper unevenness may be remedied by striking with a mallet and straight board along the length of the installation.

Corner Trim Replacement

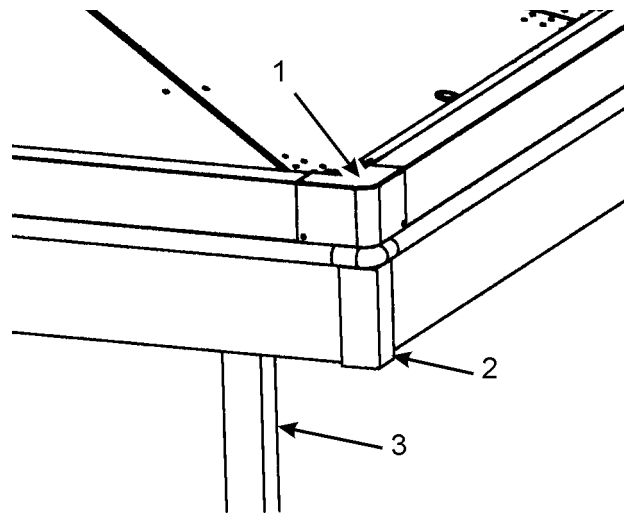

1. Remove four screws and damaged upper cladding corner trim (1) from corner of the case.
2. Remove four screws and damaged upper wood cladding corner trim (2) from corner of case.
3. Remove four screws and damaged Lower wood cladding corner trim (3) from corner of the case.
4. Replace new corner trim in the reverse order.

Fan Blade and Motor Replacement

WARNING

Shut off or disconnect power supply to case before servicing a fan. Automatic cycling of fan or electrical power to wire ends could cause personal injury and/or death.

Fan Blade Replacement

1. Remove bottom screens and bottom trays from case.

CAUTION

Electrical wiring to fan circuit is still connected. Careless removal could damage the wiring.

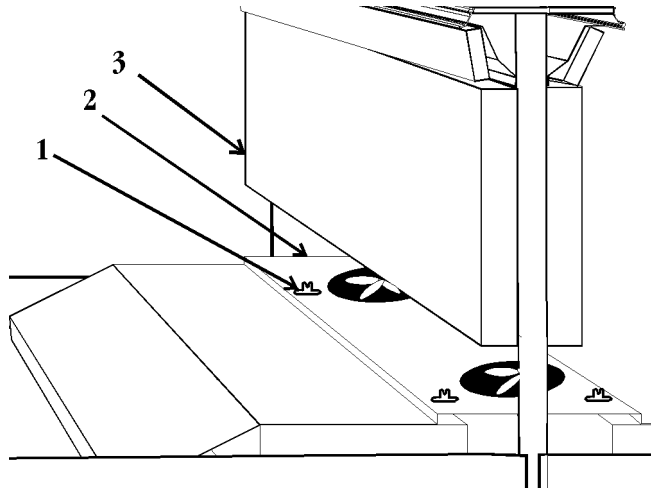

2. Turn thumbscrews (1) and carefully lift out the fan plenum (2) from under the center riser (3).

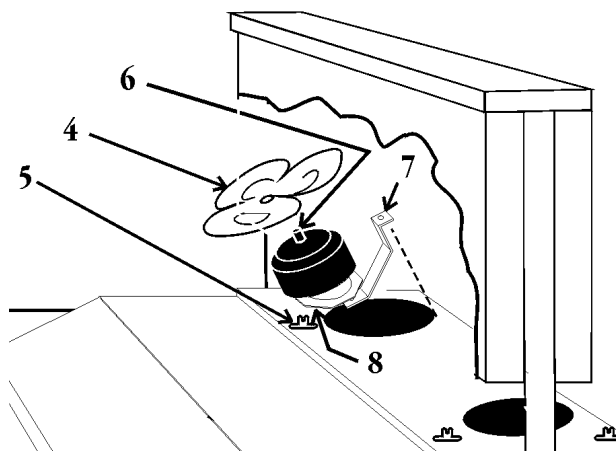

3. To replace fan blade (4), remove spring clip (5) and fan blade (4) from fan motor shaft (6). Discard spring clip.
4. Install new fan blade (4) on fan motor shaft (6) and secure with new spring clip (5).
5. Replace fan plenum, bottom trays and bottom screens in case.

Fan Motor Replacement

1. Remove bottom screens and bottom trays from case.

CAUTION

Electrical wiring to fan circuit is still connected. Careless removal could damage the wiring.

2. Turn thumbscrews (1) and carefully lift out the fan plenum (2) from under the center riser (3).
3. Remove three screws and mounting brackets (7) and fan plenum (2).
4. Carefully lift fan motor assembly and unplug wire connector.
5. Remove three screws, bracket mounting plate (8) and mounting brackets (7) from fan motor (6).

NOTE

If replacement blades and/or motor are not available, unplug motor and cover opening until the replacement parts are available.

6. Replace new fan motor assembly in reverse order.

PARTS INFORMATION**Cladding and Optional Trim Parts List**

Item Description	NRPIE		NRPIEE	
	8'	12'	8'	12'
1 Upper Side Cladding, Maple	9810790 (2)	9806923 (2)	9801791 (2)	9806928 (2)
Screw, BLK	9800299	9800299	9800299	9800299
2 Upper Side Cladding, MB	9810792 (2)	9806930 (2)	9810792 (2)	9806930 (2)
3 Side Bumper Retainer, 1"	9039125 (2)	9039179 (2)	9039125 (2)	9039179 (2)
Screw, BLK	9800299	9800299	9800299	9800299
4 1" Side Bumper, BLK	9810831 (2)	9806987 (2)	9810831 (2)	9806987 (2)
5 Bumper Corner Trim, BLK	9806939 (2)	9806939 (2)	9806939 (4)	9806939 (4)
Screw, BLK	9800299	9800299	9800299	9800299
6 Upr. Cladding Corner Trim, MB	9810700 (2)	9810700 (2)	9810700 (4)	9810700 (4)
Screw	5205439	5205439	5205439	5205439
7 Base Cladding, Maple	9810789 (2)	9806943 (2)	9810793 (2)	9806933 (2)
Screw	5053985	5053985	5053985	5053985
8 Base Cladding Corner Trim	9806986 (2)	9806986 (2)	9806986 (4)	9806986 (4)
9 Base Cladding Support, MB	9806935	9806935	9806935	9806935
Screw	5183536	5183536	5183536	5183536
10 End Base Cladding, Maple	9806934	9806934	9806934 (2)	9806934 (2)
Screw	5053985	5053985	5053985	5053985
11 End Base Cladding Support, MB	9806936	9806936	9806936 (2)	9806936 (2)
Rivet	5104957	5104957	5104957	5104957
12 Upr. End Cladding Corner Trim	9806985 (2)	9806985 (2)	9806985 (4)	9806985 (4)
13 Upr. End Cladding, Maple	9806929	9806929	9806929 (2)	9806929 (2)
Screw, BLK	9800299	9800299	9800299	9800299
14 Upr. End Cladding, MB	9806931	9806931	9806931 (2)	9806931 (2)
15 End Bumper Retainer, 1"	9027886	9027886	9027886 (2)	9027886 (2)
Screw, BLK	9800299	9800299	9800299	9800299
16 1" End Bumper, BLK	9806988	9806988	9806988 (2)	9806988 (2)
17 Upr. Side Cladding Joint Trim, MB	9810813	9813813	-----	-----
Screw	5205439 (4)	5205439 (4)	-----	-----

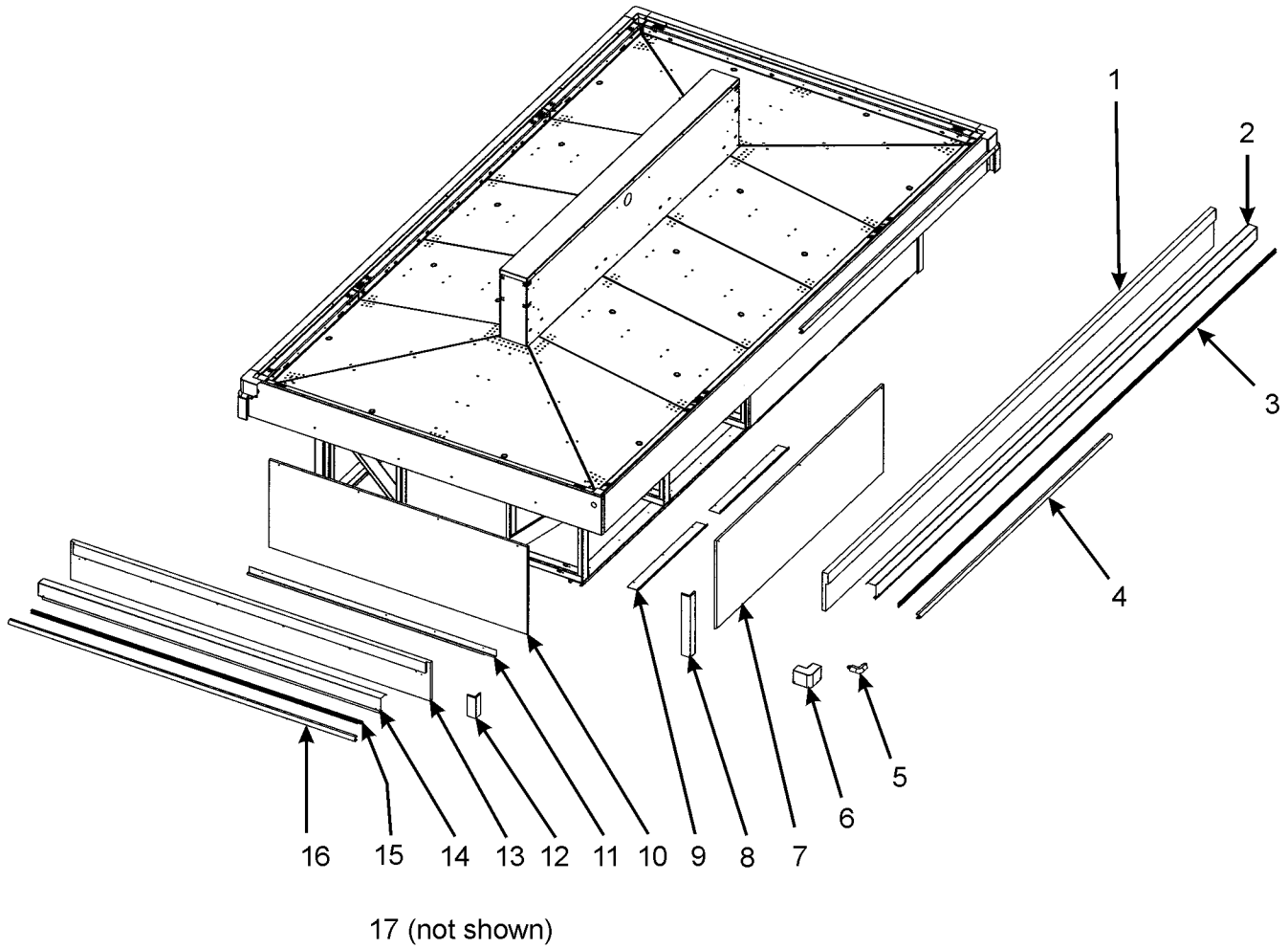

Operational Parts List

Case Usage	Domestic	
Electrical Circuit	115 Volt 60 Hertz	
Case Size	8'	12'
Fan Motor	5125532 5 Watt	5125532 5 Watt
Fan Motor Brackets		
(NRPIE)	5197471	5187471
(NRPIEE)	5197471	5197471
Fan Bracket Plate	9041077	9041077
Fan Blades (7.75" 32° 3B)	5126000	5126000
Opt. ECM Fan Motor	9025002 8 Watt	9025002 8 Watt
Opt. ECM Fan Brackets and Fan Blades	Same as Used on Standard Fan.	
NSF Product Thermometer	5967100	5967100

For information on operational parts not listed above contact the TYLER Service Parts Department.