

NVD service merchandisers provide forced air, lower-coil cooling that maximizes product integrity. A single sealed triple-pane front glass offers seamless front viewing while increasing the case's insulating factor, providing an energy-efficient alternative to lift glass versions. Vertical glass minimizes the reflection and glare of ambient lighting.



**Features & Benefits**

- Energy-efficient copper tube and aluminum fin coils.
- Single row of T8 top lights for increased product illumination.
- Vertical thermopane glass minimizes glare and eliminates condensation.
- 22-1/2" clear sliding rear doors for easy access to interior.
- Easily removable interior components for quicker cleaning.
- Pipe leg base and removable kickplate facilitate cleaning under the case.
- Ice trays keep seafood fresh and enhance product presentation.
- Ample room for the display of dry-goods on the case top provides opportunity for impulse sales of related products.
- Off-cycle defrost.

**Options**

- Second row of energy efficient T8 top lights with remote electronic ballast.
- Glass windows on patch end panels.
- Lighted or unlighted stainless steel mezzanine shelves.
- Angled or reinforced ice trays.
- Scale shelves.

Specifications are subject to engineering changes without notice.

Model	Case Length	Description	Capacity in Cubic Feet
NVD	6' • 8' • 12'	Fixed Vertical Front Glass with forced air standard coil	23.0 • 30.7 • 46.1

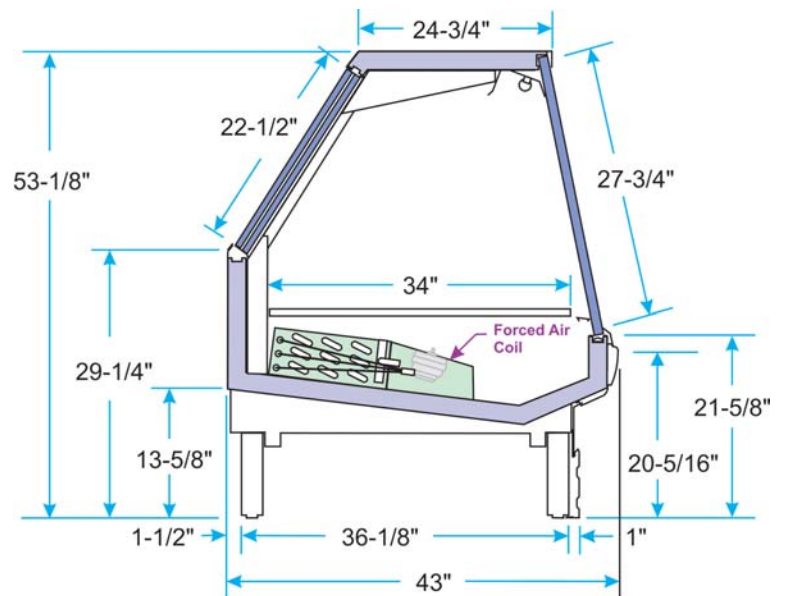

**Optional Accessories**



Stainless steel mezzanine shelves help to maximize the product viewing area and can be ordered with or without lights.

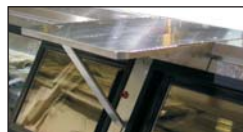

Scale Shelves add more functionality to the work area.

