

## NVF Fixed Vertical Glass



NVF vertical glass seafood service merchandisers provide gravity-coil cooling and ice trays to keep seafood products at their freshest. A single sealed triple-pane front glass offers seamless front viewing while increasing the case's insulating factor, providing an energy-efficient alternative to lift glass versions. The vertical glass minimizes the reflection and glare of ambient lighting.

Meat / Seafood



### Features & Benefits

- ♦ Energy-efficient copper tube and aluminum fin coils.
- ♦ Single row of T8 top lights for increased product illumination.
- ♦ Vertical triple-pane glass minimizes glare and eliminates condensation.
- ♦ 22-1/2" clear sliding rear doors for easy access to interior.
- ♦ Easily removable interior components for quicker cleaning.
- ♦ Pipe leg base and removable kickplate facilitate cleaning under the case.
- ♦ Ice trays keep seafood fresh and enhance product presentation.
- ♦ Ample room for the display of dry-goods on the case top provides opportunity for impulse sales of related products.
- ♦ Off-cycle defrost.

### Options

- ♦ Second row of energy efficient T8 top lights with remote electronic ballast.
- ♦ Glass windows on patch end panels.
- ♦ Angled or reinforced ice trays.
- ♦ Scale shelves.

Specifications are subject to engineering changes without notice.

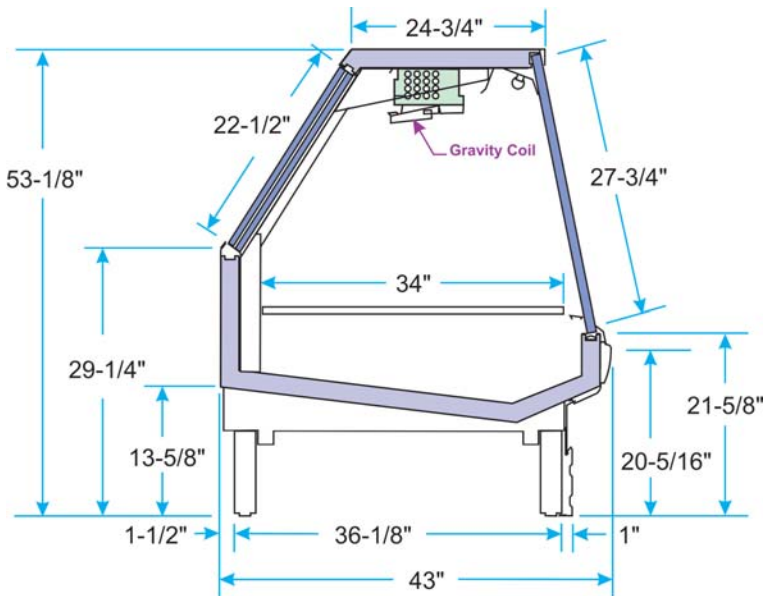

Model	Case Length	Description	Capacity in Cubic Feet
NVF	6' • 8' • 12'	Fixed vertical Front Glass with std top gravity coil	21.9 • 29.3 • 43.8

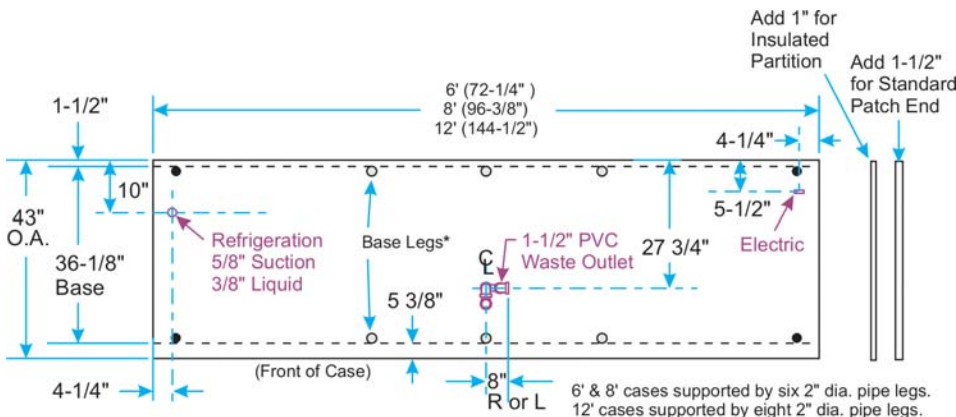

### Optional Accessories



Scale Shelves add more functionality to the work area.