

Our RCCG island merchandisers have rounded Plexiglas® corners and a streamlined single-piece tub design for superior product visibility that is attractive to your customers from any direction. The RCCG comes with three riser options that allow for additional presentation possibilities.



Model RCCG8 with Riser Option 2 shown.



**Features & Benefits**

- Energy-efficient copper tube and aluminum fin coils .
- Single row of energy-efficient T8 canopy lights per side for additional product accent lighting.
- Seamless insulated fiberglass body provides a pleasing streamline look.
- Curved Plexiglas® perimeter enhances product presentation.
- Removable fan assembly allows access to coil and drain pan.
- Off-cycle defrost.

**Options**

- ECM fan motors for additional energy savings.
- Up to two rows of energy-efficient T8 lighted shelves surround the center riser for increased product presentation.
- 2" additional riser heights.
- 4" lower profile body design.
- Stainless steel bakery step and riser.

Specifications are subject to engineering changes without notice.

Model	Case Length	Description	Capacity in Cubic Feet*
RCCG (Std. Riser)	8' • 12' • 16'	Curved Perimeter Plexiglas® with Standard Riser, standard coils	21.8 • 32.6 • 43.5
RCCG (Riser Opt. 1)	8' • 12' • 16'	Curved Perimeter Plexiglas® with Riser Option 1, standard coils	35.1 • 52.6 • 70.1
RCCG (Riser Opt. 2)	8' • 12' • 16'	Curved Perimeter Plexiglas® with Riser Option 2, standard coils	36.3 • 54.4 • 72.5

\* Riser Option 1 cubic capacity is based on one row of 12" shelving surrounding the center riser. Riser Option 2 cubic capacity is based on two rows of 12" shelving surrounding the center riser.

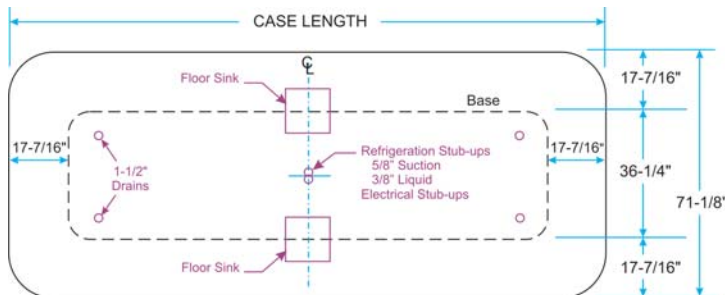

**Optional Accessories**

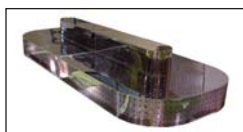

This Stainless Steel Bakery Step and Riser distributes cool air evenly over larger areas.

**RCCG with Standard Riser**

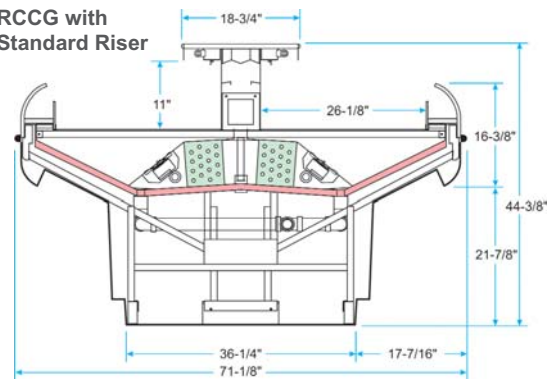

**RCCG with Riser Option 1**

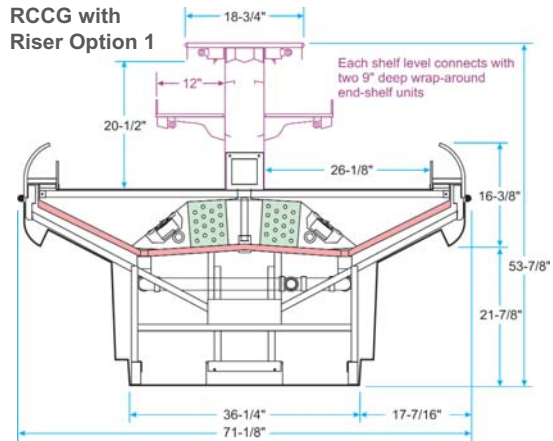

**RCCG with Riser Option 2**

