

A^{series} Advantage

Installation & Service Manual

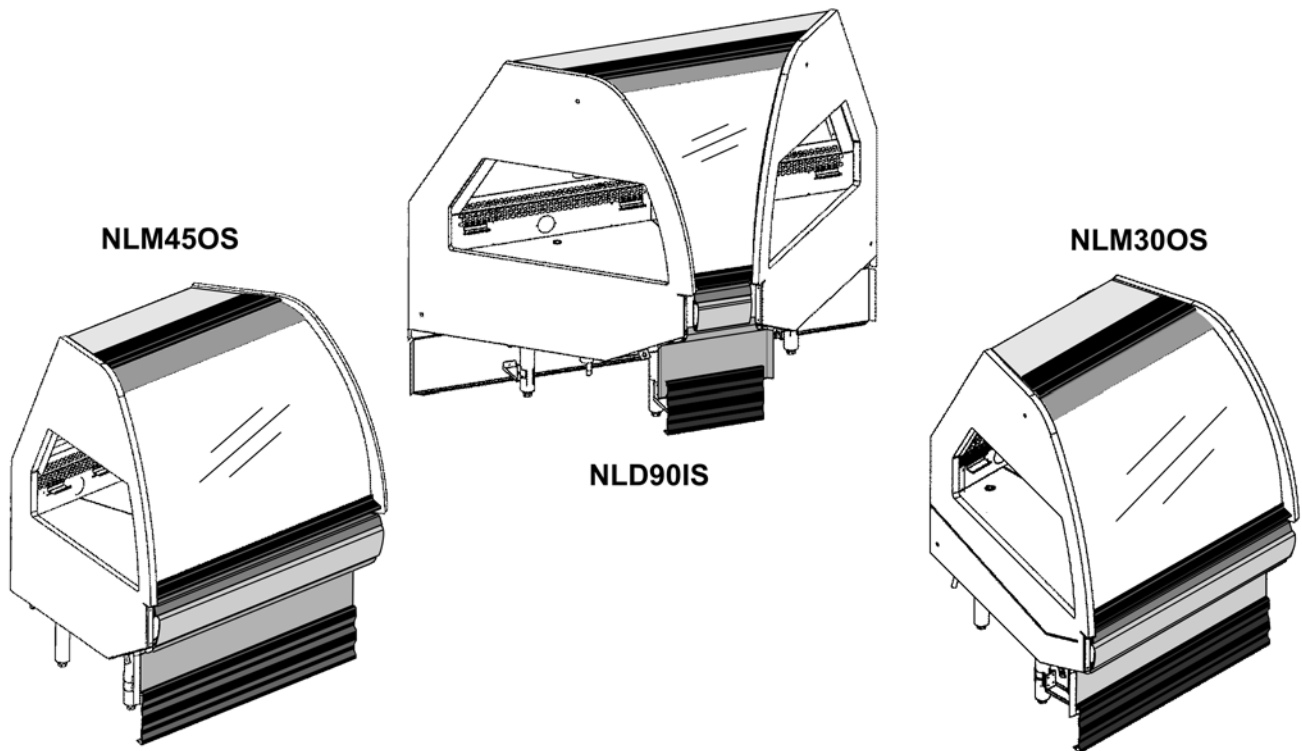

SERVICE CORNER (WEDGE) CASES

INSIDE & OUTSIDE CORNER MERCHANDISERS

Refrigerated Corner Display Cases

This manual has been designed to be used in conjunction with the General (UL/NSF) Installation & Service Manuals. Save the Instructions in Both Manuals for Future Reference!!

This merchandiser conforms to the American National Standard Institute & NSF International Health and Sanitation standard ANSI/NSF 7 - 2003.

PRINTED IN U.S.A.	Specifications subject to change without notice.	REPLACES EDITION 4/07	ISSUE DATE 4/08	PART NO. 9037170	REV. D
-------------------	--	-----------------------	-----------------	------------------	--------

CONTENTS

	<u>Page</u>
Specifications	
Fixed Curved Glass Service Wedge Merchandisers	4
Fixed Vertical Glass Service Wedge Merchandiser	7
Line Sizing Requirements (See General-UL/NSF I&S Manual)	
Pre-Installation Responsibilities (See General-UL/NSF I&S Manual)	
Installation Procedures	
Carpentry Procedures	9
Case Line-Up and Pull-Up Locations	9
Trim & Thermostat Installation	10
Plumbing Procedures (See General-UL/NSF I&S Manual)	
Refrigeration Procedures	10
Temperature Control	10
Setting Electronic Thermostat	11
Electrical Procedures	12
Electrical Considerations	12
Defrost Information	12
Defrost Control Chart	12
Wiring Diagrams	12
NL(M/D)/NF(M/D)IS/OS & NVMOS	
Domestic & Export (50 Hz) Corner Case Circuits	13
Cleaning and Sanitation	14
Component Removal and Installation Instructions for Cleaning	14
Lower Trays and Screens	14
Front Air Ducts	14
Rear Air Ducts	14
Front Lower Cladding	14
Front Upper Cladding	14
Cleaning Instructions	14
Stainless Steel Cleaning Methods	15
General Information	
Rear Door Removal and Installation	17
Service Instructions	
Preventive Maintenance (See General-UL/NSF I&S Manual)	
Fan Blade & Motor Replacement (See General-UL/NSF I&S Manual)	
Light Servicing	17
Ballast and Lighting Locations	17
Curved Glass and/or Anti-Sweat Replacement	18
Vertical Glass Replacement	19
Color Band, Bumper & Bumper Retainer Replacement	20

	<u>Page</u>
Parts Information	21
Cladding and Trim Parts List	21
Operational Parts List	23
TYLER Warranty	(See General-UL/NSF I&S Manual)

The following Medium Temperature Fixed Curved Front Glass Gravity & Blower Service; Fixed Vertical Front Glass Gravity Service; and Fixed Curved Front Glass Bakery Corner Merchandiser models are covered in this manual:

MODEL	DESCRIPTION
NLM15OS	15° OUTSIDE FIXED CURVED GLASS GRAVITY COIL SERVICE CORNER MERCHANDISER
NLM30OS	30° OUTSIDE FIXED CURVED GLASS GRAVITY COIL SERVICE CORNER MERCHANDISER
NLM45IS/ NFM45IS	45° INSIDE FIXED CURVED GLASS GRAVITY COIL SERVICE CORNER MERCHANDISERS
NLM45OS/ NFM45OS	45° OUTSIDE FIXED CURVED GLASS GRAVITY COIL SERVICE CORNER MERCHANDISERS
NVM45OS	45° OUTSIDE FIXED VERTICAL GLASS GRAVITY COIL SERVICE CORNER MERCHANDISER
NLM90OS	90° OUTSIDE FIXED CURVED GLASS GRAVITY COIL SERVICE CORNER MERCHANDISER
NLD45IS/ NFD45IS	45° INSIDE FIXED CURVED GLASS BLOWER COIL SERVICE CORNER MERCHANDISERS
NLD45OS/ NFD45OS	45° OUTSIDE FIXED CURVED GLASS BLOWER COIL SERVICE CORNER MERCHANDISERS
NLD90IS	90° INSIDE FIXED CURVED GLASS BLOWER COIL SERVICE CORNER MERCHANDISER
NLD90OS	90° OUTSIDE FIXED CURVED GLASS BLOWER COIL SERVICE CORNER MERCHANDISER

SPECIFICATIONS

Fixed Curved Glass Gravity & Blower Service Wedge Merchandisers

Refrigeration Data:

MODEL	CASE LENGTH	CASE USAGE	CAPACITY (BTUH)		EVAPORATOR (°F)	UNIT SIZING (°F)	DISCHARGE AIR		AVG. REF. CHARGE (LBS/CS)
			PARALLEL	CONVENTIONAL			TEMPERATURE (°F)	VELOCITY (FPM)	
NLM15OS	29-1/4"	GRAVITY-MEAT	305*	330*	+13**	+11	N/A	N/A	----
NLM30OS	33-5/8"	GRAVITY-MEAT	402*	435*	+13**	+11	N/A	N/A	----
NLM45IS	44"	GRAVITY-MEAT	419*	454*	+13**	+11	N/A	N/A	----
NLM45OS	50"	GRAVITY-MEAT	549*	594*	+13**	+11	N/A	N/A	----
NLM90OS	77"	GRAVITY-MEAT	664*	719*	+13**	+11	N/A	N/A	----
NFM45IS	44"	GRAVITY-MEAT	419*	454*	+13**	+11	N/A	N/A	----
NFM45OS	50"	GRAVITY-MEAT	549*	594*	+13**	+11	N/A	N/A	----
NLD45IS	44"	FORCED AIR-DELI	687*	710*	+15**	+13	----	-----	----
NLD45OS	50"	FORCED AIR-DELI	776*	802*	+15**	+13	----	-----	----
NLD90IS	71"	FORCED AIR-DELI	817*	844*	+15**	+13	34	310***	----
NLD90OS	77"	FORCED AIR-DELI	865*	894*	+15**	+13	31	617***	----
NFD45IS	44"	FORCED AIR-DELI	687*	710*	+15**	+13	----	-----	----
NFD45OS	50"	FORCED AIR-DELI	894*	923*	+15**	+13	----	-----	----

* Capacity data listed for cases with 1 row of compact top lights. For sizing all refrigeration equipment other than TYLER, use conventional BTUH values.

** Evaporator temperature is based on the saturated pressure leaving the case.

*** Air velocity measured 1 hour after defrost at the vertical part of the Rear Duct.

FOR SPECIFIC COMPRESSOR SIZING INFORMATION, REFER TO TYLER APPLICATIONS FOR RACK SYSTEM COMPRESSORS AND/OR THE COMPRESSOR MANUFACTURERS FOR SINGLE COMPRESSORS. FOR LINE SIZING INFORMATION, REFER TO THE MISCELLANEOUS SECTION "BUFF" IN THE TYLER SPECIFICATION GUIDE.

Electrical Data:

Fans and Heaters (120 Volt)

MODEL	FANS / CASE	TOTAL STANDARD FANS		TOTAL ECM FANS		TOTAL ANTI-SWEATS OUTER GLASS SUPPORT	
		AMPS	WATTS	AMPS	WATTS	AMPS	WATTS
NLM Wedges - ALL	N/A	N/A	N/A	N/A	N/A	N/A	N/A
NFM Wedges - ALL	N/A	N/A	N/A	N/A	N/A	N/A	N/A
NLD Wedges - ALL	1	0.34	30.2	-----	-----	0.60	72.0
NFD Wedges - ALL	1	0.34	30.2	-----	-----	0.60	72.0

T8 Lighting with Electronic Ballasts (120 Volt)

MODEL	TOP LIGHTS - PER ROW				MAXIMUM LIGHTING *	
	AMPS		WATTS		AMPS	WATTS
	(1 ROW)	(2 ROWS)	(1 ROW)	(2 ROWS)	(1 or 2 ROWS)	(1 or 2 ROWS)
NLM15OS	0.29	N/A	34.8	N/A	0.29	34.8
NLD30IS	0.29	N/A	34.8	N/A	0.29	34.8
NLM45IS / NFM45IS	0.29	N/A	34.8	N/A	0.29	34.8
NLD45IS / NFD45IS	0.29	N/A	34.8	N/A	0.29	34.8
NLD90IS	0.54	N/A	64.8	N/A	0.54	64.8
NLM45OS / NFM45OS	N/A	0.40	N/A	48.0	0.40	48.0
NLD45OS / NFD45OS	N/A	0.34	N/A	40.8	0.34	40.8
NLM90OS / NLD90OS	N/A	0.54	N/A	64.8	0.54	64.8

* 1 row of compact top lights for inside corner cases and 2 rows of compact top lights for outside corner cases.

Defrost Data:

DEFROST TYPE	DEFROSTS PER DAY	DURATION TIME (MIN)	TERMINATION TEMP. (°F)	BACKUP PRESSURE SETTINGS *		EPR SETTINGS **		DEFROST WATER (LB / DAY)			
				CUT IN	CUT OUT	R22 (PSIG)	R404A (PSIG)	45IS	45OS	90IS	90OS
TIME OFF - NLM / NFM	1	110	N/A	34# @ R22	24# @ R22	36	47	----	----	----	----
TIME OFF - NLD / NFD	1	46	N/A	34# @ R22	24# @ R22	36	47	----	----	1.1	1.8

* Used with electronic thermostat and EPR control. ** Set EPR to give this pressure at the case.

An evaporator Pressure Regulator should be installed on each system to aid in temperature control. Set the EPR for 36 PSIG (R22).

Pressure control settings shown in the above table are for backup purposes only. The actual temperature control should be set by the thermostat.

NLMOS, NFMOS, NLMIS or NFMIS setting for this case = CUT IN @ 17°F and CUT OUT @ 15°F. NLDOS or NFDOS setting for this case = CUT IN @ 34°F and CUT OUT @ 28°F. NLDIS or NFDIS setting for this case = CUT IN @ 41°F and CUT OUT @ 26°F.

The information contained herein is based on technical analysis and/or tests performed in a controlled lab environment that are consistent with industry practices, and is intended as a reference for system sizing and configuration purposes only and for use by persons having technical skill at their own discretion and risk. Conditions of use are outside of Tyler's control and we do not assume and hereby disclaim any liability for results obtained or damages incurred through application of or reliance on the data presented, including but not limited to specific energy consumption with any particular model or installed application. SPECIFICATIONS ARE SUBJECT TO CHANGE WITHOUT NOTICE.

Installation & Service

SERVICE & BAKERY CORNER CASES

NSF CERTIFIED to meet ANSI/NSF - 7.

CASE BTUH REQUIREMENTS are calculated to produce approximately the indicated performance with absolute maximum operating ambient limits of 75°F & 55RH.

NLM / NFM WEDGE CROSS SECTION

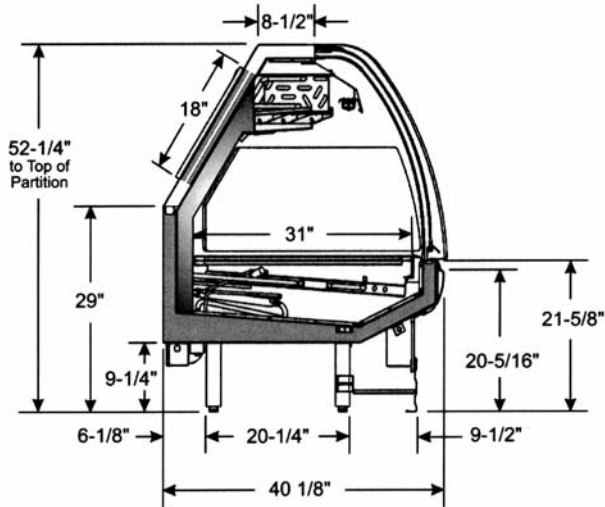

NLD / NFD WEDGE CROSS SECTION

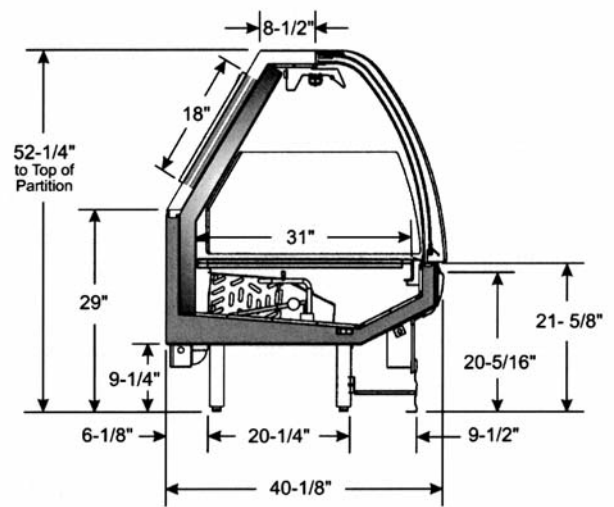

These drawings show the dimensions for the NLM45OS, NFM45OS, NLD45OS or NFD45OS. Width dimensions will vary on all other wedge cases. See floor plan views for specific width dimensions.

SERVICE WEDGE FLOOR PLANS

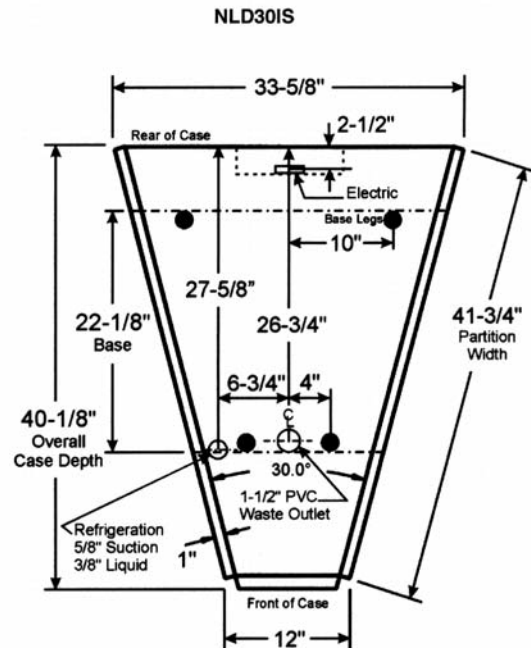
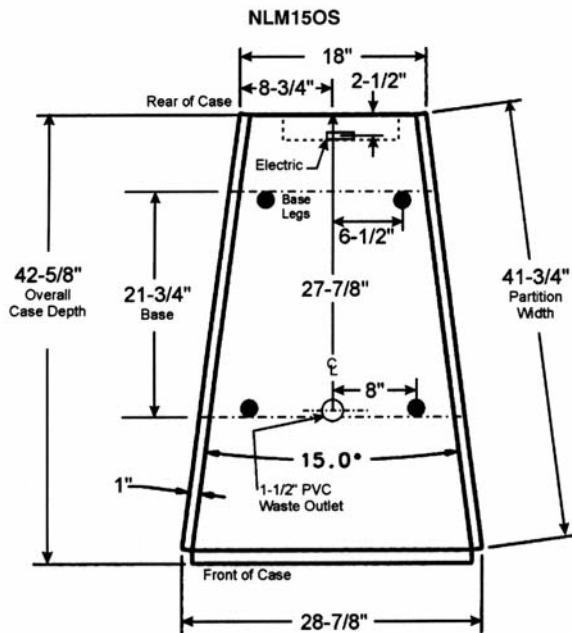

NL(M/D)450S / NF(M/D)450S

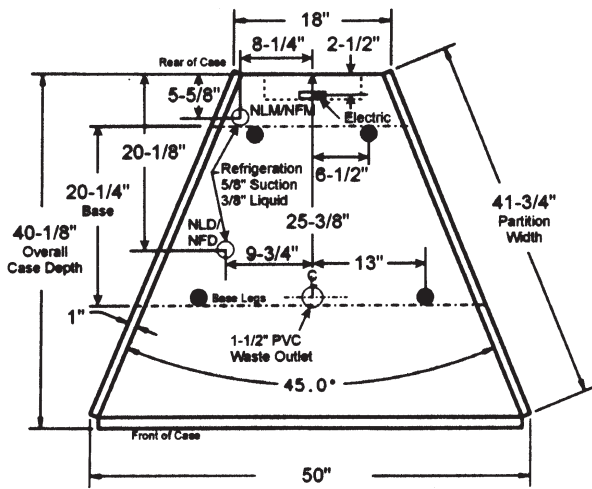

NL(M/D)45IS / NF(M/D)45IS

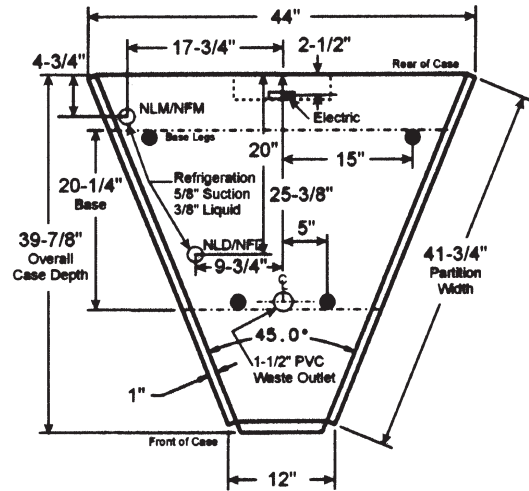

NL(M/D)900S

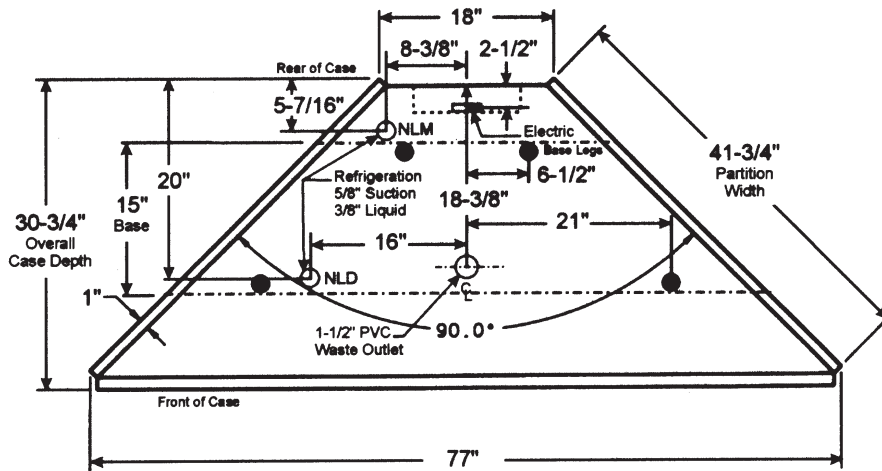

NLD90IS

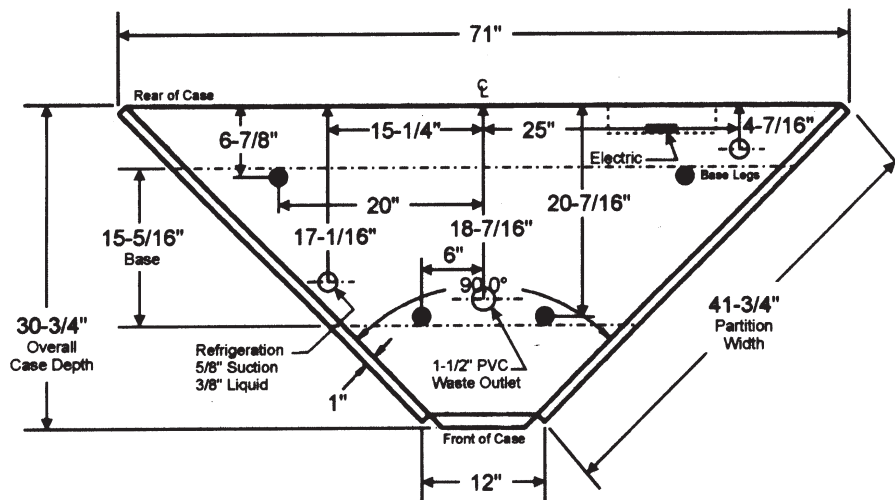

SERVICE & BAKERY CORNER CASES

Installation & Service

Fixed Vertical Glass Gravity Service Wedge Merchandiser

Refrigeration Data:

MODEL	CASE LENGTH	CASE USAGE	CAPACITY (BTUH)		EVAPORATOR (°F)	UNIT SIZING (°F)	DISCHARGE AIR		AVG. REF. CHARGE (LBS/CS)
			PARALLEL	CONVENTIONAL			TEMPERATURE (°F)	VELOCITY (FPM)	
NVM45OS	50"	GRAVITY-MEAT	673*	729*	+13**	+11	N/A	N/A	----

* Capacity data listed for cases with 1 row of compact top lights. For sizing all refrigeration equipment other than TYLER, use conventional BTUH values.

** Evaporator temperature is based on the saturated pressure leaving the case.

*** Air velocity measured 1 hour after defrost at the vertical part of the Rear Duct.

FOR SPECIFIC COMPRESSOR SIZING INFORMATION, REFER TO TYLER APPLICATIONS FOR RACK SYSTEM COMPRESSORS AND/OR THE COMPRESSOR MANUFACTURERS FOR SINGLE COMPRESSORS. FOR LINE SIZING INFORMATION, REFER TO THE MISCELLANEOUS SECTION "BUFF" IN THE TYLER SPECIFICATION GUIDE.

Electrical Data:

Fans and Heaters (120 Volt)

MODEL	FANS / CASE	TOTAL STANDARD FANS		TOTAL ECM FANS		TOTAL ANTI-SWEATS	
		AMPS	WATTS	AMPS	WATTS	AMPS	WATTS
NVM45OS	N/A	N/A	N/A	N/A	N/A	N/A	N/A

T8 Lighting with Electronic Ballasts (120 Volt)

MODEL	TOP LIGHTS – PER ROW				MAXIMUM LIGHTING *	
	AMPS (1 ROW) (2 ROWS)		WATTS (1 ROW) (2 ROWS)		AMPS (1 or 2 ROWS)	WATTS (1 or 2 ROWS)
NVM45OS	N/A	0.40	N/A	48.0	0.40	48.0

* 2 rows of compact top lights for outside corner cases.

Defrost Data:

DEFROST TYPE	DEFROSTS PER DAY	DURATION TIME (MIN)	TERMINATION TEMP. (°F)	BACKUP PRESSURE SETTINGS *		EPR SETTINGS **		DEFROST WATER (LB / FT / DAY)
				CUT IN	CUT OUT	R22 (PSIG)	R404A (PSIG)	
TIME OFF	1	110	N/A	34# @ R22	24# @ R22	36	47	----

* Used with electronic thermostat and EPR control.

** Set EPR to give this pressure at the case.

An evaporator Pressure Regulator should be installed on each system to aid in temperature control. Set the EPR for 36 PSIG (R22).

Pressure control settings shown in the above table are for backup purposes only. The actual temperature control should be set by the thermostat. NVMOS setting for this case = CUT IN @ 17°F and CUT OUT @ 15°F.

NSF CERTIFIED to meet ANSI/NSF – 7.

CASE BTUH REQUIREMENTS are calculated to produce approximately the indicated performance with absolute maximum operating ambient limits of 75°F & 55RH.

The information contained herein is based on technical analysis and/or tests performed in a controlled lab environment that are consistent with industry practices, and is intended as a reference for system sizing and configuration purposes only and for use by persons having technical skill at their own discretion and risk. Conditions of use are outside of Tyler's control and we do not assume and hereby disclaim any liability for results obtained or damages incurred through application of or reliance on the data presented, including but not limited to specific energy consumption with any particular model or installed application. SPECIFICATIONS ARE SUBJECT TO CHANGE WITHOUT NOTICE.

NVM450S SERVICE WEDGE CROSS SECTION

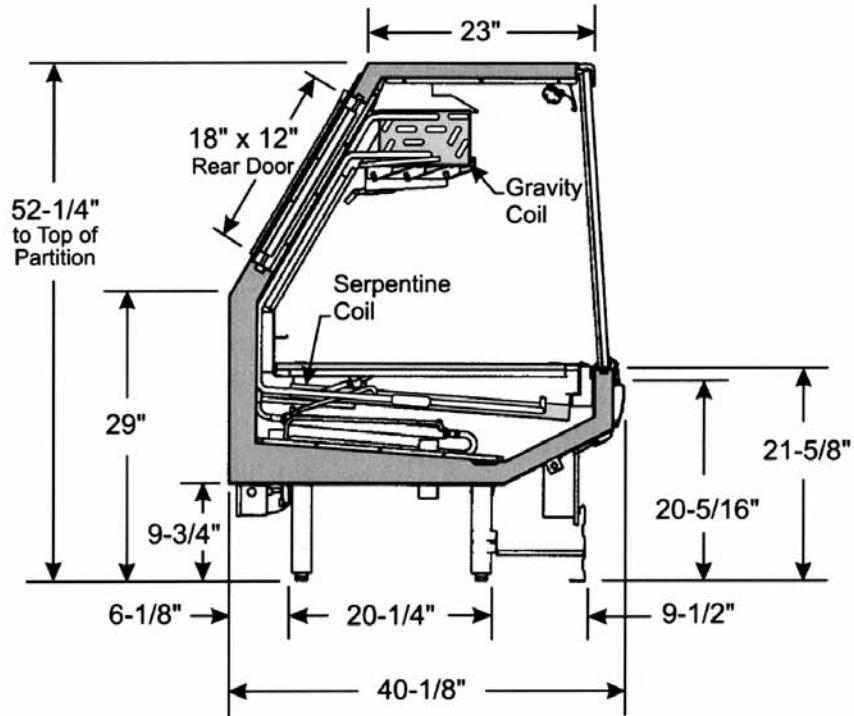

This drawing show the dimensions for the NVM450S.
See floor plan views for specific width dimensions.

NVM450S SERVICE WEDGE FLOOR PLAN

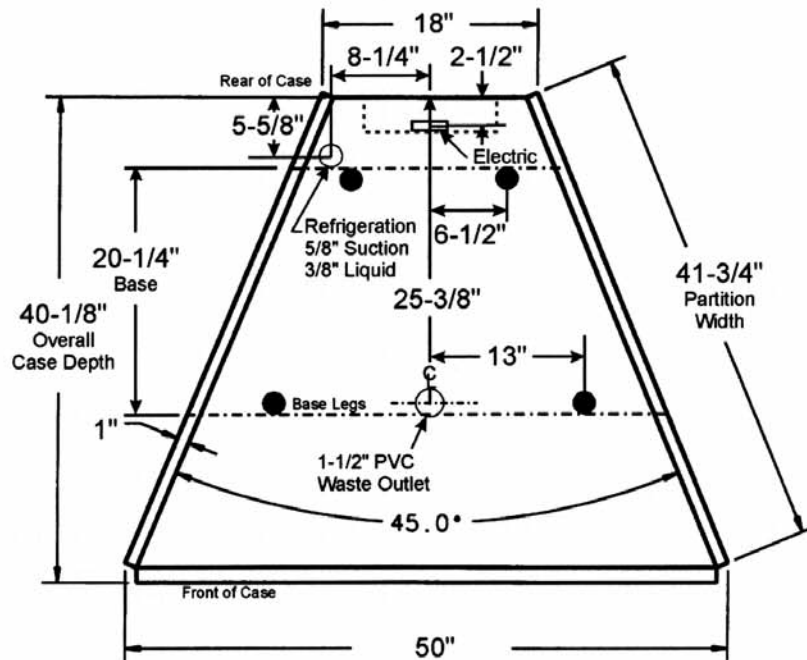

SERVICE & BAKERY CORNER CASES

Installation & Service

INSTALLATION PROCEDURES

WARNING

Corner cases are not intended as stand alone commercial refrigerated merchandisers. They must be bolted to the adjoining case(s) to provide stability. Failure to do so could result in product damage and/or possible personal injury.

NOTE

All service corner cases have fixed front glass in them. The front glass cannot be raised for cleaning or merchandising.

Carpentry Procedures

Case Line-Up and Pull-Up Locations

Before starting the case line-up, review the store layout floorplans and survey the areas where case line-ups are going to be installed.

WARNING

Corner cases can be very heavy and possibly top heavy before they are secured in a line-up. Always use a lifting device to remove case from skid and two or more people to move and position case. Improper handling of these cases could result in product damage and/or personal injury.

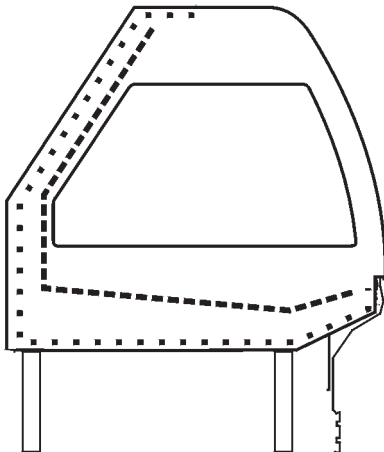

1. Apply two heavy beads of caulking compound from the Filler Kit to the ends of the adjoining cases at dotted (. . .) and dashed (- - -) lines. Proper caulking provides good case refrigeration and sanitation.

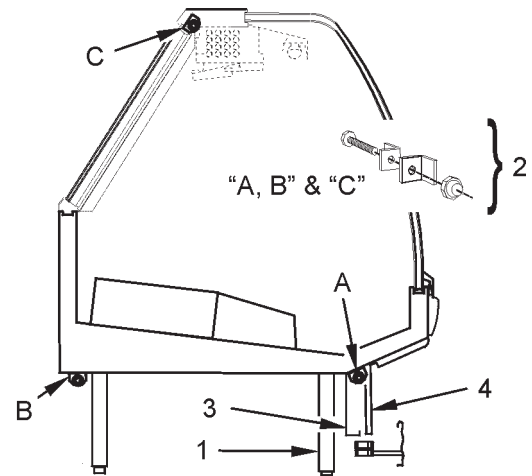

2. Using an appropriate lifting device, lift corner case from skid and install four pipe legs. Lower corner case to floor.
3. Position corner case at end of service case line-up so front bumpers and case pull-ups line up.
4. Adjust leg inserts in bottom of pipe legs (1), up to 1 1/2", to align and level pull-ups and bumpers. Push corner case tight against case line-up.

CAUTION

Do not drill or use other holes through the case end for pull-ups. This may deform the case end and could cause joint leaks and/or poor refrigeration.

NOTE

Top inside pull-up must be accessed through adjoining case.

5. Secure corner case to case line-up by installing pull-up bolts and mounting hardware (2) at pull-up locations, (A, B & C). **NOTE:** Do not tighten any pull-up hardware until all of it has been installed. Tighten all pull-up hardware equally starting at point A and finishing at point C. **Do not overtighten.**
6. Install lower front cladding support (3) to foam body with screw.
7. Install lower front cladding (4) and secure to upper front cladding and lower front cladding support (3) with screws.

Trim & NSF Thermometer Installation

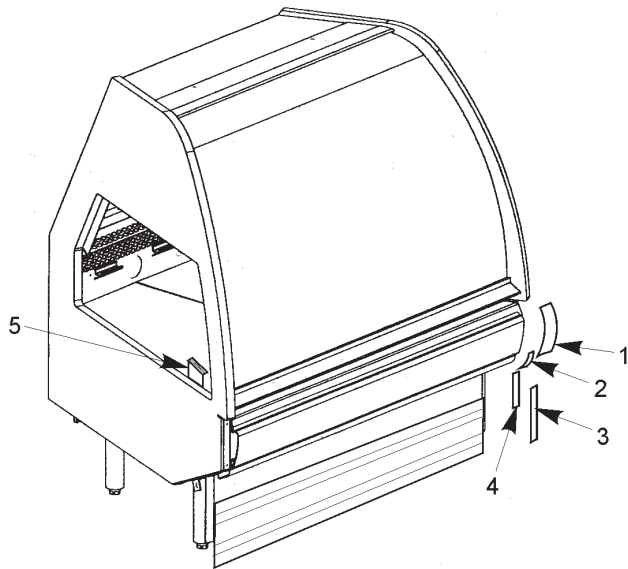

The joint trim and mounting hardware are shipped loose. Trim includes bumper joint trim (1), front upper cladding joint trim (2), front lower cladding joint trim (3) and kickplate joint trim (4).

The NSF product thermometer and bracket assembly (5) is shipped loose with the case. After removing the thermometer and bracket assembly from the shipping packaging, position it on the inside of the front bottom left window cutout in the partition. Secure bracket to partition with two screws.

Refrigeration Procedures

Refrigeration system and superheat instructions can be found in the "General UL/NSF) I&S Manual". Service corner case temperature control information is listed below.

Temperature Control

The temperature control of each corner case is controlled with a thermostat and suction line solenoid. One thermostat and one solenoid are required each corner case.

The NLM, NLD, NFM, NFD and NVM corner cases use an electronic thermostat for improved temperature control.

Service Corner Case with Gravity Coil

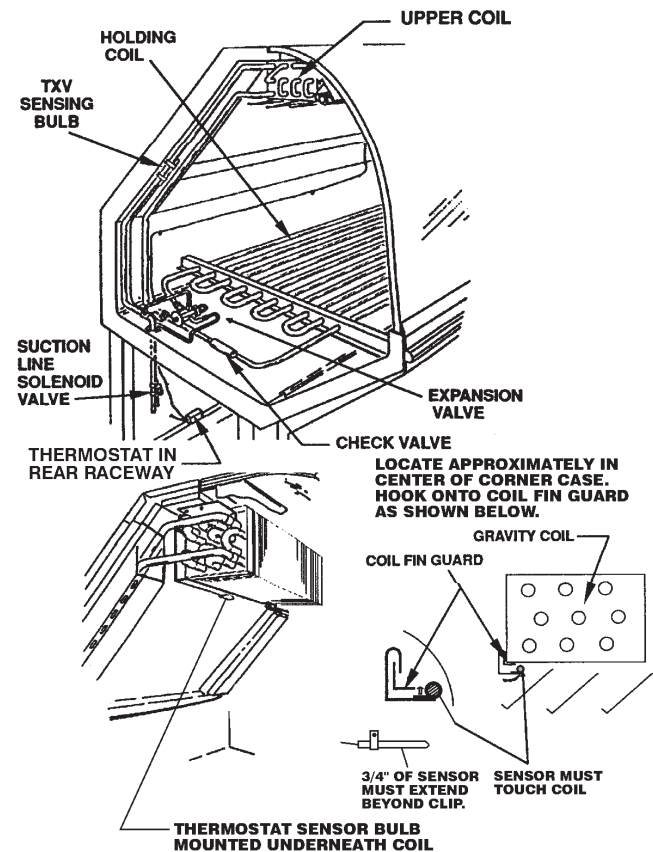

Service Corner Case with Blower Coil

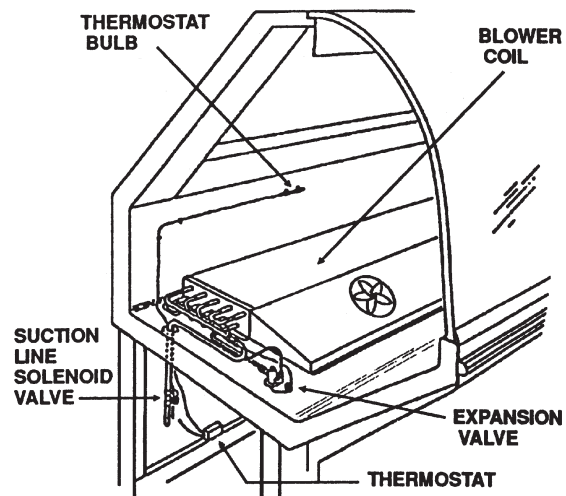

In addition to the thermostat and suction solenoid, a suction stop EPR valve is required in the suction line. The EPR valve acts as a low pressure limit to aid in the overall temperature control.

Installation & Service

Setting Electronic Thermostat

1. Remove four screws and cover from the electronic thermostat.
2. Connect sensor wires to the common (COM) and sensor (SEN) terminals of the terminal strip located at the top left of the printed circuit board. The sensor leads are interchangeable.

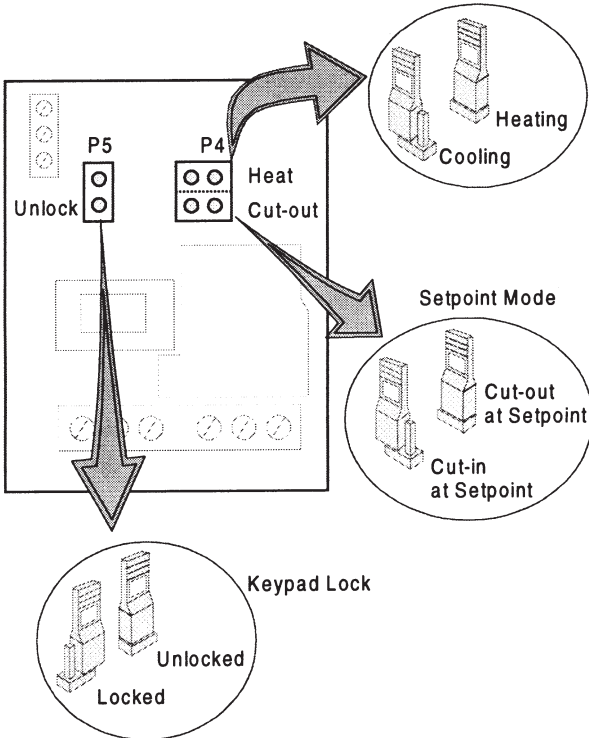

3. Set the Heating/Cooling jumper blocks to the "COOL" position.
4. Set the Cut-in at Setpoint/Cut-out at Setpoint jumper blocks to the "Cut-out at Setpoint" position.
5. Set the Keypad Locked/Unlocked jumper blocks to the "Unlocked" position.
6. Replace the electronic thermostat cover and secure with four screws.

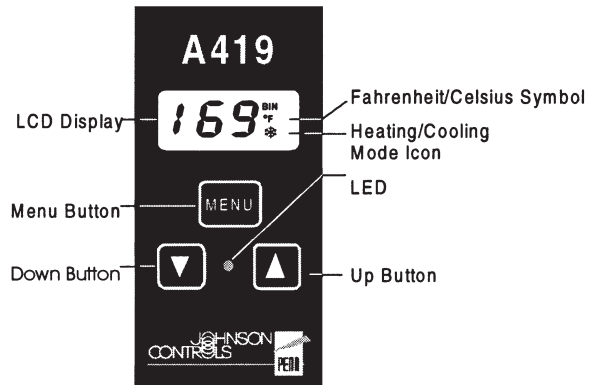

7. To adjust the setpoint:
 - a. Push the Menu Button. "SP" will flash on the LCD display.
 - b. Push the Menu Button one more time and setpoint temperature will be displayed.
 - c. Push the Up or Down Button until the desired setpoint is displayed.
(NLM/NFM/NVM (OS or IS) = 15°F, NLD/NFD (OS or IS) = 28°F or NLD/NFD (IS) = 26°F)
 - d. Push the Menu Button.
8. To adjust the differential:
 - a. Push the Menu Button. "SP" will flash on the LCD display.
 - b. Push the Down Button until "DIF" is shown on the LCD display.
 - c. Push the Menu Button one more time and a differential number will be displayed.
 - d. Push the Up or Down Button until the desired differential setting is displayed.
(NLM/NFM/NVM (OS or IS) = 2°F, NLD/NFD (OS) = 6°F or NLD/NFD (IS) = 15°F)
 - d. Push the Menu Button.

With the cooling mode selected, the differential is ABOVE the setpoint. The relay will be energized and the LED indicator will illuminate when the temperature reaches the differential setting. When the temperature drops to the setpoint, the relay and LED indicator will de-energize and refrigeration will stop.

The settings above are specific to TYLER service cases. Other applications will require different setpoints and differentials.

Electrical Procedures

Electrical Considerations

Electrical wiring on service corner cases can be accessed by removing the rear lower panel (1) to expose an electrical terminal box where the wires should be connected.

CAUTION

Make sure all electrical connections at components and terminal blocks are tight. This prevents burning of electrical terminals and/or premature component failure.

NOTE

The electrical components and/or ballast are located in the electrical terminal box at the rear of the case.

Case Fan Circuit (NLD Corner Cases)

This circuit is to be supplied by an uninterrupted, protected 120V circuit. The corner case fan circuit is not cycled on this case.

Fluorescent Lamp Circuit

Service corner case lighting is supplied by PL-L folded lamps with electronic ballasts. It is controlled by a light switch in each case. The standard lighting is 1-row of horizontal canopy lights.

Anti-Sweat Circuit (NLD/NFD Corner Cases)

All anti-sweat heaters are wired directly to the main power supply so they can operate at all times.

Defrost Information

See “General (UL/NSF) I&S Manual” for operational descriptions for each type of defrost control.

Defrost Control Chart

NLM/NFM/NVM Corner Case Defrost Option Settings

Defrost Type	Defrosts Per Day	Defrost	
		Duration (Min)	Term. Temp.
Off Time	1	110	-----

NLD/NFD Corner Case Defrost Option Settings

Defrost Type	Defrosts Per Day	Defrost	
		Duration (Min)	Term. Temp.
Off Time	1	46	-----

Thermostat and sensor locations are shown on page 10 of this manual.

WIRING DIAGRAMS

ELECTRICIAN NOTE - OVERCURRENT PROTECTION

120V circuits should be protected by 15 or 20 Amp devices per the requirements noted on the cabinet nameplate or the National Electrical Code, Canadian Electrical Code - Part 1, Section 28. 208V defrost circuits employ No. 12 AWG field wire leads for field connections. On remote cases intended for end to end line-ups, bonding for ground may rely upon the pull-up bolts.

The wiring diagram on page 15 will cover all NLM, NLD, NFM, NFD and NVM OS and IS corner case circuits.

NLM/NFM/NVM/NLD/NFD/NLBR Dom. & Exp. (50 Hz) Corner Case Circuits

TYLER
REFRIGERATION DIVISION

PART TYPE N T S I
MODEL X
FABRICATED
PURCHASED
DEPT CC X W

1. TO OBTAIN INFORMATION CONC. CLAIMS RIGHTS
2. THE INFORMATION IS FOR YOUR INFORMATION ONLY.
3. ALL DIMENSIONS ARE IN INCHES UNLESS
4. OTHERWISE INDICATED TO FINISHED PART AFTER
5. ANY TREATMENT IS ALLOWED.

WIRE LEGEND	NO.	COLOR
	1	RED
	2	BLUE
	3	YELLOW
	4	PINK
	5	ORANGE
	6	BLACK
	7	WHITE
	8	GREEN

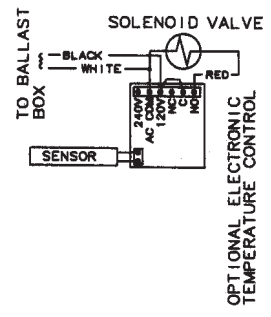
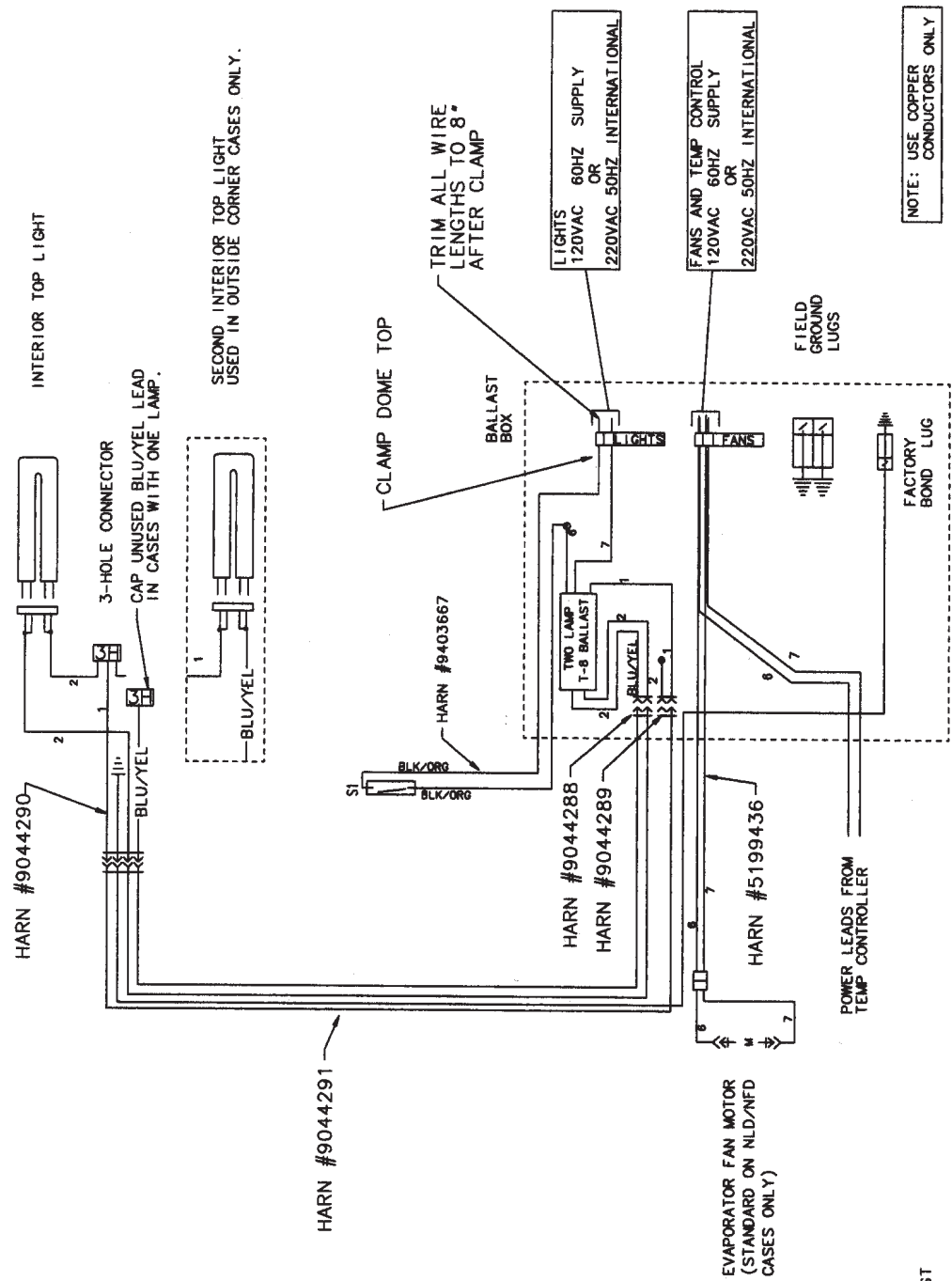

NOTE: ALL CASES MUST BE GROUNDED

REV	DESCRIPTION	DATE	BY	CHK	13	12	11	10	9	8	7	6	5	4	3	2	1
E	REVISDED WIRING TO BAL BOX	26253	21SEP00	LC	CK												
D	REMOVED OPTIONAL LIGHTS	26180	21AUG00	LC	CK												
C	ADD HARNESS ID	25952	28JUN00	LC	CK												
B	REVISDED PMR INPUT BLOCK	25924	19MAY00	LC	CK												
REV	DESCRIPTION	RELEASE	DATE	BY	CHK	13	12	11	10	9	8	7	6	5	4	3	2

DECIMALS +/- .030 ANGLES +/- 1 DEG

DIA WIRING NLM/NF (F)(M)(D) IS/OS COR

9401632

CLEANING AND SANITATION

Component Removal and Installation Instructions for Cleaning

Lower Trays and Screens

1. Open rear door or access from adjoining case.
2. Remove product from the case interior.
3. Grasp and lift out each screen and lower tray from the bottom of the case.
4. After cleaning, replace in reverse order.

Front Air Ducts

1. Remove screens and lower trays, see this page.
2. Lift out front air duct sections and remove through rear door or adjoining case.
3. After cleaning, replace in reverse order.

Rear Air Ducts

1. Remove screens, brackets and lower trays, see this page.
2. Remove mounting screws from rear air duct.
3. Lift out rear air duct sections and remove through rear door or adjoining case.
4. After cleaning, replace in reverse order.

Front Lower Cladding

1. Remove screws, kickplate corner trim and lower cladding corner trim.
2. Remove the front kickplate.
3. Remove bottom screws and pull down front lower cladding to clear top tabs from front upper cladding. Remove front lower cladding from case.
4. After cleaning, replace front lower cladding by inserting top tabs in front upper cladding and secure it with bottom screws. Replace front kickplate.

Front Upper Cladding

1. Remove curved glass, color band, bumper and bumper retainer from the case. See pages 18 and 19.
2. Remove screws and bumper corner trim.
3. Remove screws, kickplate corner trim, lower cladding corner trim, and upper

cladding corner trim.

4. Remove the front kickplate.
5. Remove screws and front lower cladding.

NOTE

Lower cladding support bracket will come off when bottom screws are removed from front upper cladding.

6. Remove screws from bottom and sides of front upper cladding and remove lower cladding support bracket and front upper cladding.
7. After cleaning, replace lower cladding support bracket, front upper cladding and remaining front components in the reverse order.

Cleaning Instructions

CAUTION

- **When cleaning this case, try not to introduce water into the case faster than it can be carried away by the waste outlet.**
- **Liquid chlorine bleach is corrosive to metals. The use of bleach or products containing bleach will damage metal surfaces and void the case warranty.**
- **Sanitize the case with Quaternary Ammonium Solutions (ex: KAYQUAT II, J-512 Sanitizer, SANIQUAT 512, etc...) approved per 21CFR 178.1010, followed by adequate draining and air drying. These solutions may be obtained from Kay Chemical Co., Johnson Wax Professional, Coastwide Laboratories, etc....**
- **Always use a soft cloth or sponge with mild detergent and water to clean any glass. Never use abrasives or scouring pads to clean glass. They can scratch and/or damage the glass.**

WARNING

TYLER Refrigeration does not recommend the use of high pressure cleaning equipment on service style cases!! The sealing of front glass and end joints is critical in these cases and high pressure cleaners can penetrate and/or damage these seals. Damaged seals allow water leaks and/or air leaks that can cause poor case refrigeration.

Installation & Service

Stainless Steel Cleaning Methods

The cleaning data in the following stainless steel cleaning chart was supplied by AISI. The information was supplied by Prime Metals Division, Alumax Aluminum Corporation.

TYPE OF CLEANING	CLEANING AGENT*	APPLICATION METHOD**	EFFECT ON FINISH
Routine cleaning	Soap, ammonia or detergent and water.	Sponge with cloth, then rinse with clear water and wipe dry.	Satisfactory for use on all finishes.
Smears and fingerprints	Arcal 20, Lac-O-Nu, Lumin Wash O' Cedar Cream Polish, Stainless Shine	Rub with cloth as directed on the package.	Satisfactory for use on all finishes. Provides barrier film
Stubborn spots and stains, baked-on splatter, and other light discolorations	Allchem Concentrated Cleaner	Apply with damp sponge or cloth.	Satisfactory for use on all finishes.
	Samae, Twinkle, or Cameo Copper Cleaner	Rub with damp cloth.	Satisfactory for use on all finishes if rubbing is light.
	Grade FFF Italian pumice, whitening or talc	Rub with damp cloth.	Use in direction of polish lines on No. 4 (polished) finish. May scratch No. 2 (mill) and No. 7 and 8 (polished) finishes.
	Liquid NuSteel	Rub with dry cloth. Use a small amount of cleaner.	Use in direction of polish lines on No. 4 (polished) finish. May scratch No. 2 (mill) and No. 7 and 8 (polished) finishes.
	Paste NuSteel or DuBois Temp	Rub with dry cloth. Use a small amount of cleaner.	Use in direction of polish lines on No. 4 (polished) finish. May scratch No. 2 (mill) and No. 7 and 8 (polished) finishes.
	Cooper's Stainless Steel Cleaner, Revere Stainless Steel Cleaner	Apply with damp sponge or cloth.	Use in direction of polish lines on No. 4 (polished) finish. May scratch No. 2 (mill) and No. 7 and 8 (polished) finishes.
	Grade F Italian pumice, Steel Bright, Lumin Cleaner, Zud or Restoro	Rub with a damp cloth.	Use in direction of polish lines on No. 4 (polished) finish. May scratch No. 2 (mill) and No. 7 and 8 (polished) finishes.
Heat tint or heavy discoloration	Penny-Brite or Copper-Brite	Rub with a dry cloth. Use a small amount of cleaner.	Use in direction of polish lines on No. 4 (polished) finish. May scratch No. 2 (mill) and No. 7 and 8 (polished) finishes.
	Penny-Brite or Copper-Brite	Rub with a dry cloth.	Use in direction of polish lines on No. 4 (polished) finish. May scratch No. 2 (mill) and No. 7 and 8 (polished) finishes.
	Paste NuSteel or DuBois Temp	Rub with dry cloth. Use a small amount of cleaner.	Use in direction of polish lines on No. 4 (polished) finish. May scratch No. 2 (mill) and No. 7 and 8 (polished) finishes.
	Revere Stainless Steel Cleaner	Apply with a damp sponge or cloth.	Use in direction of polish lines on No. 4 (polished) finish. May scratch No. 2 (mill) and No. 7 and 8 (polished) finishes.

SERVICE & BAKERY CORNER CASES



<u>TYPE OF CLEANING</u>	<u>CLEANING AGENT*</u>	<u>APPLICATION METHOD**</u>	<u>EFFECT ON FINISH</u>
	Allen Polish, Steel Bright, Wyandotte, Bab-O or Zud	Rub with a damp cloth.	Use in direction of polish lines on No. 4 (polished) finish. May scratch No. 2 (mill) and No. 7 and 8 (polished) finishes.
Burnt-on foods and grease, fatty acids, milkstone (where swabbing or rubbing is not practical)	Easy-Off, De-Grease-It, 4-6% hot solution of such agents as trisodium tripolyphosphate, or 5-15% caustic soda solution	Apply generous coating. Allow to stand for 10-15 min. Repeated application may be necessary.	Excellent removal, satisfactory for use on all finishes.
Tenacious deposits, rusty discolorations, industrial atmospheric stains	Oakite No. 33, Dilac, Texo 12, Texo N.Y., Flash-Klenz, Caddy Cleaner, Turco Scale 4368 or Permag 57.	Swab and soak with clean cloth. Let stand 15 minutes or more according to directions on package. Rinse and dry.	Satisfactory for use on all finishes.
Hard water spots and scale	Vinegar	Swab or wipe with a cloth. Rinse with water and dry.	Satisfactory for use on all finishes.
	5% oxalic acid, 5% sulamic acid, 5-10% phosphoric acid, or Dilac, Oakite No. 33, Texo 12 or Texo N.Y.	Swab or soak with a cloth. Let stand 10-15 minutes. Always follow with neutralizer rinse, and dry.	Satisfactory for use on all finishes. Effective on tenacious deposits or where scale has built up.
Grease and oil	Organic solvents such as carbon tetrachloride, trichlorethylene, acetone, kerosene, gasoline, benzene, alcohol and chlorethane n.u.	Rub with a cloth. Organic solvents may be flammable and/or toxic. Observe all precautions against fire. Do not smoke while vapors are present. Be sure area is well ventilated.	Satisfactory for use on all finishes.

* Use of proprietary names is intended only to indicate a type of cleaner, and does not constitute an endorsement, nor is omission of any proprietary cleanser to imply its inadequacy. It should be emphasized that all products should be used in strict accordance with instructions on package.

** In all applications a sponge or fibrous brush or pad are recommended. DO NOT use ordinary steel wool, steel brushes, chlorine bleach or products containing bleach for cleaning or sanitizing stainless steel.

Installation & Service

GENERAL INFORMATION

Rear Door Removal & Installation

The rear door in all corner cases is a removable door with post hinges. The post hinges are located on the top and bottom of the left side of the door. The rear door comes factory installed in the door frame. These doors are removable for cleaning and to aid in case maintenance. **NOTE: DO NOT FULLY IMMERSE DOORS WHEN CLEANING.**

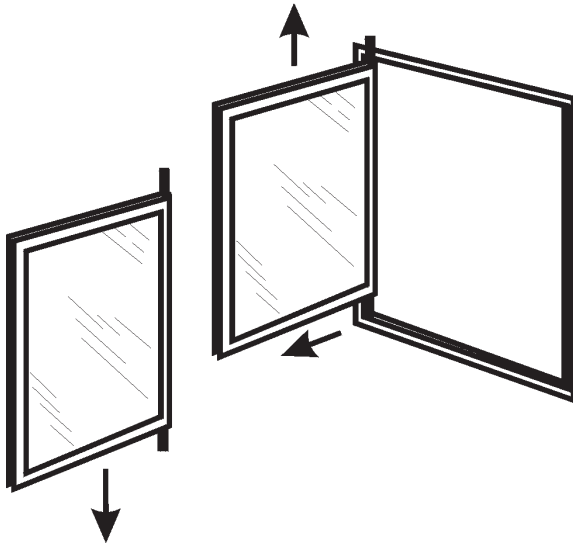

To remove the rear door, open the door and lift up until the bottom door post hinge can be removed from the door frame. After the bottom post hinge has cleared the door frame, pull the door down and lift out the door assembly.

NOTE

Make sure the nylon grommet in the top of the door frame does not fall out. Nylon grommet must be in place to assure proper door fit, operation and securing of door in the door frame.

To replace the rear door, insert the top post hinge in the top grommet in the door frame. Lift rear door up until the bottom post hinge can clear the door frame. Insert bottom post hinge in the bottom hole in the door frame and lower the door into place. Close the rear door.

SERVICE INSTRUCTIONS

See "General (UL/NSF) I&S Manual" for fan blade and motor (NLD/NFD corner case only) replacement instructions.

Light Servicing

Ballast and Lighting Locations

All light ballasts are located in the electrical box behind the rear rail cover.

In order to retain safety approval with Underwriters Laboratory and the Canadian Standards Association, the mounting of electrical components and interconnecting wires must not deviate from the following instructions. Only qualified personnel are authorized to install the accessory items. TYLER Refrigeration recommends you order all component parts from its Service Parts Department.

Ballast Replacement

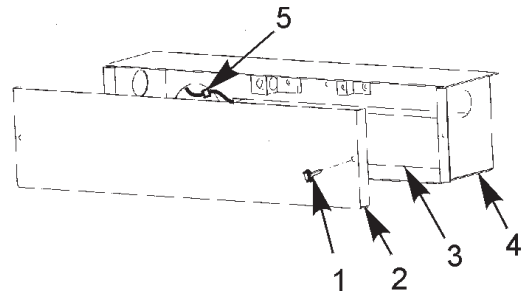

1. Remove screws (1) and rear electrical box cover (2) from rear of corner case.

NOTE

If tappit screws are not available, a starwasher should be used between the ballast and the heads of the screws.

2. Remove and install required number of ballasts (3) in rear electrical box (4) with two screws each.
3. Identify and connect required wiring harnesses (upper, lower, etc...) to the wire connector leads (5) from the ballast(s) (3).
4. Replace rear electrical box cover (2) and secure with screws (1).

Compact Lamp Replacement

CAUTION

Shut off light switch or disconnect power supply before changing a lamp. Lighting system power and/or ballast surges can burn out adjacent lamps if power is left on.

1. Open rear door to access the compact lamps.

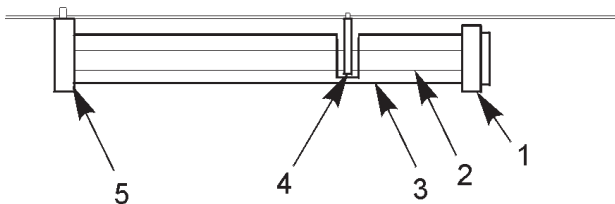

2. Remove lampshield end cap (1).
3. Gently pull down on lamp (2) and light shield (3) to release end from retainer clip (4).
4. Unseat and slide off light shield (3) from lamp (2).
5. Carefully grasp and pull lamp (2) until it releases from the receptacle (5).
6. Insert new lamp (2) in receptacle (5) until it snaps into place.
7. Slide on lampshield (3) until it is fully seated on the receptacle (5).

NOTE

Slot in lampshield must line up with retainer clip to allow for proper lamp securing.

8. Snap lamp (2) and lampshield (3) into retainer clip (4). Install lampshield end cap (1) over open end of lampshield (3).

Curved Glass and/or Anti-Sweat Replacement

Glass Removal (NLM/NFM/NLD/NFD)

Front Glass Support Anti-Sweat Removal (NLD/NFD)

NOTE

Glass must be removed to access the screws in the top of the color band.

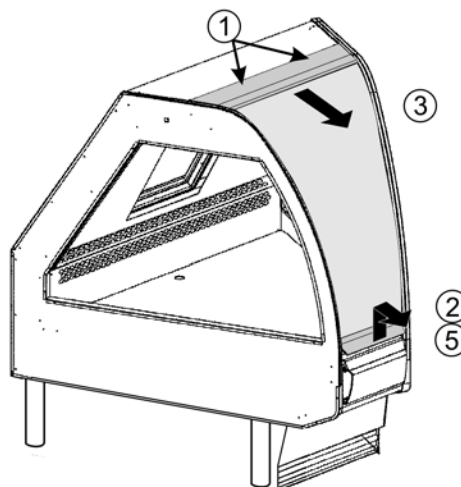

1. Using a screwdriver, remove caps over screw holes and turn both screw locks 1/4 turn counterclockwise to release them.
2. Firmly lift up and out on front glass handle until the outer glass assembly air seal releases.
3. Grasp both sides of the outer plexiglas and slide the top glass trim out of the retainer glass clip at the top of the case.
4. Repeat steps 2 and 3 to remove the inner glass assembly from the case.

NOTE

Check for defective bottom glass support anti-sweat. If replacement is required, perform step 5.

5. Disconnect anti-sweat wires from case wires. Remove screws and bottom glass support from case. Remove defective anti-sweat from bottom glass support.

Installation & Service

Anti-Sweat/Glass Installation

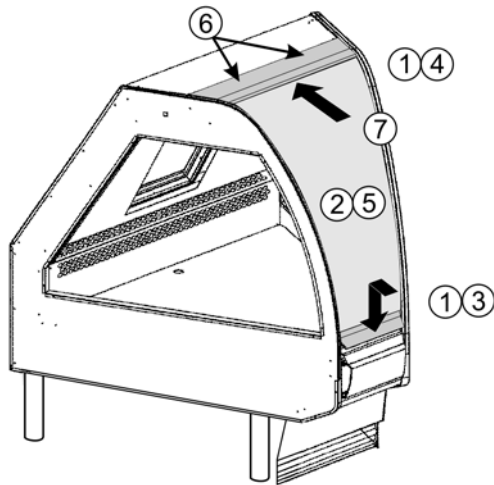

1. If removed, install anti-sweat in bottom glass trim and install bottom glass trim. Reconnect anti-sweat wires to case wires. Position inner glass assembly in case on bottom glass trim and on top glass supports.
2. Push firmly on the top of the plexiglas until the inner glass assembly is completely seated in the case.
3. Insert bottom edge of front glass handle on outer front glass assembly into bottom glass edge trim.
4. Line-up and position the top glass trim into the retainer glass clip at the top of the case.
5. Push firmly on the top of the plexiglas until the outer glass assembly is completely seated in the retainer glass clip.
6. While holding top of glass in, turn screw locks 1/4 turn clockwise to secure the outer glass assembly in place.
7. Press in along the sides of the plexiglas to assure a proper air seal for the outer curved glass.

Vertical Glass Replacement

Glass Removal

NOTE

Vertical glass in outside corner cases may need to be removed to access the coil for servicing and/or replacement.

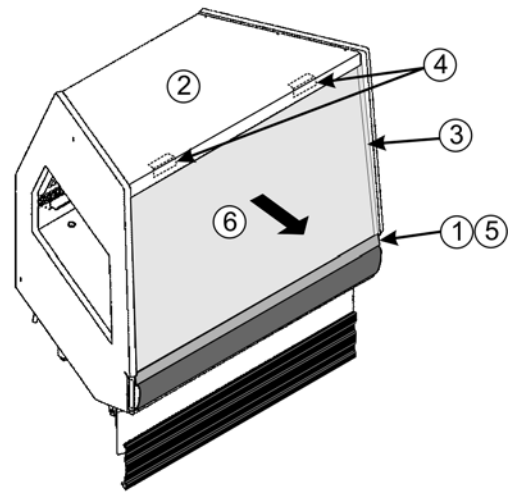

1. Carefully pry out bottom edge of color band until it releases from top edge of bumper. Pull down on color band to remove from bottom glass retainer and case.
2. Remove screws and lift off top cladding cladding from case.
3. Remove screws and LH & RH front glass closeoffs from edges of glass.

CAUTION

Use two people for remainder of glass removal. Glass is heavy! It could fall out and break, if not supported properly.

4. While person is supporting front glass, remove screws and top glass supports from case.
5. While person is supporting front glass, remove screws and bottom front glass retainer from case.
6. Using two people, carefully lift front glass from bottom glass support and remove from case.

NOTE

If bottom glass support bends during glass removal, replace it with new one during installation to assure air tight glass installation.

Glass Installation

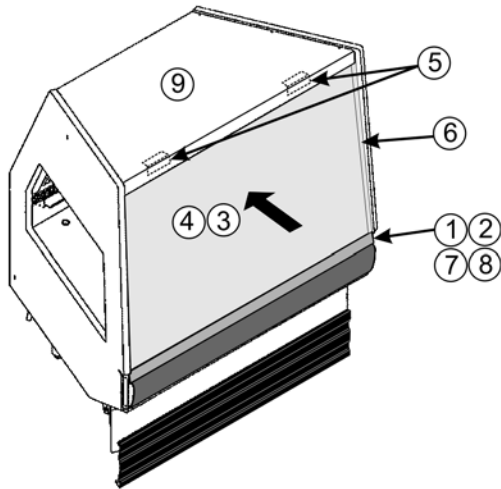

1. Install new bottom glass support on top of front foam body, if it was damaged during removal. Secure bottom glass support with screws.
2. Seal entire bottom surface of slot for glass in the bottom glass support.

CAUTION

Use two people to lift and install front glass. Glass is heavy! Glass could break if mishandled or dropped during installation.

3. Using two people, lift glass and position bottom surface in bottom glass support.
4. Position foam tape on top edge of glass and wrap foam tape on front and back glass surfaces. Lean top of glass against top foam body.
5. Secure top of glass by installing two top glass retainers with screws.
6. Install RH & LH front glass closeoffs between glass and bottom glass support and secure with screws.
7. Position front lower glass retainer on bottom glass support and hold in place with screws. **Do not tighten screws.** Install seal between top edge and glass and secure by tightening screws in lower glass retainer.

8. Install color band between lower glass retainer and top of bumper.
9. Install top cladding on top of foam body and secure with screws.

Color Band, Bumper and Bumper Retainer Replacement

NOTE

Color band, bumper and bumper retainer must be removed to access the upper screws in the front upper cladding.

NLM/NLD Corner Cases

1. Remove curved glass from case, see page 20.
2. Remove screws and bumper joint trim from front corners of the case.
3. Remove screws and color band from bottom glass support.
4. Push in on center of bumper while pulling out on bottom of bumper. This will start to separate bumper from bumper retainer.
5. Make sure the bottom of the bumper is released from the bumper retainer for the full length of the case.
6. After bottom is released, firmly pull out top of bumper to snap it free from bumper retainer.
7. Remove mounting screws and bumper retainer from front of case.
8. Install bumper retainer and bumper in reverse order.
9. Replace color band on bottom glass support and secure with screws.
10. Replace bumper joint trim and secure with screws.
11. Install the curved glass, see page 19.

Installation & Service

NFM/NFD/NVM Corner Cases

1. Remove screws and bumper joint trim from front corners of the case.
2. Pry out bottom of color band and pull down to remove it from bottom glass support.
3. Push in on center of bumper while pulling out on bottom of bumper. This will start to separate bumper from bumper retainer.
4. Make sure the bottom of the bumper is released from the bumper retainer for the full length of the case.
5. After bottom is released, firmly pull out top of bumper to snap it free from bumper retainer.
6. Remove mounting screws and bumper retainer from front of case.
8. Install bumper retainer, bumper and color band in reverse order.
9. Replace bumper joint trim and secure with screws.

PARTS INFORMATION

Cladding and Trim Parts Lists

NVM Corner Case

<u>Item</u>	<u>Description</u>	<u>45°OS</u>
1	Top Panel, MB/SS	9403440
2	Front Glass	9458094
	Front Glass Close-off	
	Right Hand, MB	9458091
	Left Hand, MB	9458090
3	Bumper Joint Trim	color per order
4	Color Band, Ptd.	9451755
5	Bumper	color per order
6	Bumper Retainer	9450134
7	Upper Cladding Joint Trim	
	Right Hand, Ptd.	9450862
	Left Hand, Ptd.	9450861
8	Upper Cladding, Ptd.	9450014
9	Lower Cladding Joint Trim	
	Standard, Ptd.	9450837
	Optional, Ptd.	9450836
10	Lower Cladding, Ptd.	
	Standard, Ptd.	9450015
	Optional, Ptd.	9450811
	Lower Cladding Support	
	Standard, Ptd.	9451048
	Optional, Ptd.	9451049
11	Kickplate Joint Trim, Ptd.	9451026
12	Kickplate Assembly	9450036
13	Pipe Leg, Std. (2" X 9.75")	9024894 (4)
	Pipe Leg, Opt. (2" X 6.00")	9024893 (4)
14	Electrical Box Cover, Ptd.	9450082
	Screw	9024814 (2)
15	Rear Door Assembly	9450139
16	NSF Thermometer	5967100
17	Opt. Rear Base Closeoff	
	for Std. Channel, Ptd.	9450040
	for Opt. Channel, Ptd.	9450095

SERVICE & BAKERY CORNER CASES



NLM/NLD/NFM/NFD Corner Cases

Item	Description	15°OS	30°OS	45°IS	45°OS	90°IS	90°OS
1	Top Panel, MB/SS	9450486	9454006	9450261	9450105	9452944	9450375
2	Outer Curved Glass Assy.	9450468	9454025	9450184	9450047	9452884	9450363
	Inner Curved Glass Assy.	9450467	9454023	9450183	9450048	9452883	9450364
3	Bumper Joint Trim, Ptd.	----- color per order -----					
4	Color Band, Ptd.						
	(NLM)	9456943	9454019	9450167	9450039	----	9450334
	(NFM)	----	----	9451751	9451755	----	----
	(NLD)		----	9450167	9450039	9452886	9450334
	(NFD)	----	----	9451751	9451755	----	----
5	Bumper	----- color per order -----					
6	Bumper Retainer	9456923	9454020	9450287	9450134	9452901	9450388
7	Upper Cladding Joint Trim						
	Right Hand	9456956	9450820	9451726	9450861	9453655	9450863
	Left Hand	9456957	9450819	9451725	9450862	9453651	9450864
8	Upper Cladding, Ptd.	9456921	9454012	9450165	9450014	9452890	9450336
9	Lower Cladding Joint Trim						
	Standard, Ptd.	9450837	9450837	9450837	9450837	9450837	9450837
	Optional, Ptd.	----	9450836	9450836	9450836	9450836	9450836
10	Lower Cladding						
	Standard, Ptd.	9456922	9450837	9450166	9450015	9452889	9450335
	Optional, Ptd.	----	----	9450812	9450811	9451989	9450813
	Lower Cladding Support						
	Standard	9451048	9451048	9451048	9451048	9451029	9451029
	Optional	----	----	9451049	9451049	9451990	9451030
11	Kickplate Joint Trim, Ptd.	----	9450868	9451024	9451026	9453645	9451025
12	Kickplate Assembly, Std.	9456927	9454030	9450205	9450036	9452885	9450315
13	Pipe Leg, Std. (2" X 9.75")	9024894(4)	9024894(4)	9024894(4)	9024894(4)	9024894(4)	9024894(4)
	Pipe Leg, Opt. (2" X 6.00")	9024893(4)	9024893(4)	9024893(4)	9024893(4)	9024893(4)	9024893(4)
14	Electrical Box Cover, Ptd.	9450082	9450082	9450082	9450082	9450082	9450082
	Screw	9024814(2)	9024814(2)	9024814(2)	9024814(2)	9024814(2)	9024814(2)
15	Rear Door Assembly	9450139	9450139	9450237	9450139	9450237	9450139
16	NSF Product Thermometer	5967100	5967100	5967100	5967100	5967100	5967100
17	Opt. Rear Base Closeoff						
	for Std. Channel	9456946	9450818	9450206	9450040	9452963	9450316
	for Opt. Channel	----	----	9450229	9450095	----	9450369

SERVICE & BAKERY CORNER CASES

Installation & Service

Operational Parts List

NLM and NFM Service Wedge Cases

Case Usage	Domestic				
Electrical Circuit	115 Volt 60 Hertz				
Case Size	15°OS	30°OS	45°IS	45°OS	90°OS
Rocker Switch	5961377	5961377	5961377	5961377	5961377
Rectangular Outlet	5236335	5236335	5236335	5236335	5236335
Compact Lamp Ballast (canopy)(1-row)	5991029	5991029	5991029	5991029	5991029
Compact Lampholder (canopy)	9045238	9045238	9045238	9045238	9045238
Compact Lamp Clip	9045239	9045239	9045239	9045239	9045239
Suction Solenoid Valve	5191445	5191445	5191445	5191445	5191445
Electronic Thermostat	5997588	5997588	5997588	5997588	5997588
Check Valve (NLM/NFM)	5199417	5199417	5199417	5199417	5199417
NSF Product Thermometer	5697100	5697100	5697100	5697100	5697100

NLD and NFD Service Wedge Cases

Case Usage	Domestic			
Electrical Circuit	115 Volt 60 Hertz			
Case Size	45°IS	45°OS	90°IS	90°OS
Fan Motor (NLD)	5125532	5125532	5125532	5125532
	5 Watt	5 Watt	5 Watt	5 Watt
Fan Motor Brackets (NLD/NFD)	5213132	5213132	5213132	5213132
Fan Bracket Plate (NLD/NFD)	9041077	9041077	9041077	9041077
Fan Blades (6" 35° 5B) (NLD/NFD)	9450091	9450091	9450091	9450091
Rocker Switch	5961377	5961377	5961377	5961377
Rectangular Outlet	5961377	5961377	5236335	5236335
Compact Lamp Ballast (canopy)(1-row)	5991029	5991029	5991029	5991029
Compact Lampholder (canopy)	9045238	9045238	9045238	9045238
Compact Lamp Clip	9045239	9045239	9045239	9045239
Suction Solenoid Valve	5191445	5191445	5191445	5191445
Electronic Thermostat	5997588	5997588	5997588	5997588
NSF Product Thermometer	5697100	5697100	5697100	5697100

For information on operational parts not listed above contact the TYLER Service Parts Department.

NVM Service Wedge Cases

Case Usage	Domestic
Electrical Circuit	115 Volt 60 Hertz
Case Size	45°OS
Rocker Switch	5961377
Rectangular Outlet	5236335
Compact Lamp Ballast (canopy)(1-row)	5991029
Compact Lampholder (canopy)	9045238
Compact Lamp Clip	9045239
Suction Solenoid Valve	5191445
Electronic Thermostat	5997588
Check Valve	5199417
NSF Product Thermometer	5697100

For information on operational parts not listed above contact the TYLER Service Parts Department.