

TYLER
REFRIGERATION



Carrier

A United Technologies Company

Allegro
S E R I E S™

Installation & Service Manual



TLM(L/R), TLD(L/R)

LIFT FRONT GLASS MEAT & DELI MITER MERCHANDISERS
Medium Temperature Service Display Cases

**This manual has been designed to be used in conjunction with the
General (UL/NSF) Installation & Service Manual.**

Save the Instructions in Both Manuals for Future Reference!

This merchandiser conforms to the American National Standard Institute & NSF International Health and Sanitation standard ANSI/NSF - 7 2003.

PRINTED IN U.S.A.	Specifications subject to change without notice.	REPLACES EDITION	8/06	ISSUE DATE	4/07	PART NO.	9805004	REV.	D
-------------------	--	------------------	------	------------	------	----------	---------	------	---

Tyler Refrigeration * Niles, Michigan 49120

CONTENTS

	<u>Page</u> <u> </u>
Specifications	
TLM(L/R) & TLD(L/R) Specification Sheets	4
Line Sizing Requirements (See General-UL/NSF I&S Manual)	
Pre-Installation Responsibilities (See General-UL/NSF I&S Manual)	
Pre-Installation Check List	7
Installation Procedures	7
Carpentry Procedures	8
Case Line-Up	8
Lift Front Glass Leveling Instructions	9
Rear Rail Cover and Close-off Installation	10
Bumper and Color Band Adjustment . . (See Gen.-UL/NSF I&S Man.)	
Optional 2" Bumper Installation	11
Plumbing Procedures (See General-UL/NSF I&S Manual)	
Refrigeration Procedures	11
Temperature Control	11
Setting the Electronic Thermostat (TLM(L/R) & TLD(L/R))	12
Electrical Procedures	13
Electrical Considerations	13
Defrost Information	13
Defrost Control Chart	13
Installation Procedure Check Lists (See Gen.-UL/NSF I&S Manual)	
Wiring Diagrams	13
TLM(L/R) Case Circuits (2' Miter, 4' Miter & 6' Miter Cases)	14
TLD(L/R) Case Circuits (2' Miter, 4' Miter & 6' Miter Cases)	15
Cleaning and Sanitation	
Component Removal and Installation Instructions for Cleaning	
Lower Trays and Screens	16
Front Air Ducts	16
Rear Air Ducts	16
Mullion Covers	16
End Coil Cover (TLM(L/R) Only)	16
Refrigeration Line Cover (TLM(L/R) Only)	16
Electrical Cover (TLM(L/R) Only)	16
Front Lower Cladding	16
Front Upper Cladding	16
Cleaning Instructions	16
Stainless Steel Cleaning Method	16

	<u>Page</u>
General Information	
Rear Sliding Door Removal and Installation	19
Mezzanine Shelving	20
Service Instructions	
Preventive Maintenance	(See General-UL/NSF I&S Manual)
Fan Blade & Motor Replacement	(See Gen.-UL/NSF I&S Manual)
Connecting the Refrigeration Piping and Components	20
Light Servicing	20
Ballast and Lighting Locations	21
Front Glass Anti-Fogging System Service	21
Front Glass Anti-Sweat Replacement	21
Front Glass Anti-Fog Fan Replacement	22
Lift-Glass Replacement	22
Lift-Glass Gas Piston Replacement	23
Color Band, Bumper and Bumper Retainer Replacement	24
Anti-Sweat Heater Wire Deflector Kit Replacement (TLD(L/R))	25
Parts Information	
Cladding and Trim Parts List	26
Operational Parts List	28
TYLER Warranty	(See General-UL/NSF I&S Manual)

The following Medium Temperature Lift Front Straight Glass Meat and Deli Miter Service Merchandiser models are covered in this manual:

MODEL	DESCRIPTION
TLM2(L/R)	41 1/4" LIFT GLASS GRAVITY COIL MEAT SERVICE MERCHANDISERS WITH LEFT OR RIGHT MITER
TLM4(L/R)	65 1/4" LIFT GLASS GRAVITY COIL MEAT SERVICE MERCHANDISERS WITH LEFT OR RIGHT MITER
TLM6(L/R)	89 1/4" LIFT GLASS GRAVITY COIL MEAT SERVICE MERCHANDISERS WITH LEFT OR RIGHT MITER
TLD2(L/R)	41 1/4" LIFT GLASS FORCED AIR COIL DELI SERVICE MERCHANDISERS WITH LEFT OR RIGHT MITER
TLD4(L/R)	65 1/4" LIFT GLASS FORCED AIR COIL DELI SERVICE MERCHANDISERS WITH LEFT OR RIGHT MITER
TLD6(L/R)	89 1/4" LIFT GLASS FORCED AIR COIL DELI SERVICE MERCHANDISERS WITH LEFT OR RIGHT MITER

SPECIFICATIONS

TLM(L/R) Lift Front Straight Glass Gravity Miter Service Merchandisers TLD(L/R) Lift Front Straight Glass Blower Miter Service Merchandisers

Refrigeration Data:

MODEL	CASE LENGTH	CASE USAGE	CAPACITY (BTUH / CASE) *		AVG. EVAP. (°F)	UNIT SIZING (°F)	DISCHARGE AIR		AVG. REF. CHARGE (LBS/FT)
			PARALLEL	CONVENTIONAL			AVG. TEMP. (°F)	VELOCITY (FPM) ***	
TLD2(L/R)	41.25"	Deli	1,409	2,114	17**	13	22	450	0.51
TLD4(L/R)	65.25"	Deli	2,229	3,344	17**	13	22	450	0.51
TLD6(L/R)	89.25"	Deli	3,049	4,574	17**	13	22	450	0.51
TLM2(L/R)	41.25"	Meat	990	1,485	19**	13	26	N/A	0.73
TLM4(L/R)	65.25"	Meat	1,566	2,349	19**	13	26	N/A	0.73
TLM6(L/R)	89.25"	Meat	2,142	3,213	19**	13	26	N/A	0.73

* Capacity data listed for cases with 1 row of T-8 top lights and 1 row of optional lighted mezzanine shelves. ADD 20 BTUH/FT for each additional top light or mezzanine shelf or a nose light. DEDUCT 20 BTUH/FT for each row of unlighted mezzanine shelves. For sizing all refrigeration equipment other than TYLER, use conventional BTUH values.

** Evaporator temperature is based on the saturated pressure leaving the case.

*** Air velocity measured 1 hour after defrost on the horizontal plane of the discharge air grill with an Anlor Jr. velometer.

FOR SPECIFIC COMPRESSOR SIZING INFORMATION, REFER TO TYLER APPLICATIONS FOR RACK SYSTEM COMPRESSORS AND/OR THE COMPRESSOR MANUFACTURERS FOR SINGLE COMPRESSORS. FOR LINE SIZING INFORMATION, REFER TO THE MISCELLANEOUS SECTION "BUFF" IN THE TYLER SPECIFICATION GUIDE.

Electrical Data:

Fans & Heaters (120 Volt)

MODEL	CASE LENGTH	FANS / CASE	TOTAL STANDARD FANS		TOTAL AMBIENT FANS		TOTAL ANTI-SWEATS	
			AMPS	WATTS	AMPS	WATTS	AMPS	WATTS
TLD2(L/R)	41.25"	3	0.34	30.2	0.32	38.4	0.90	107.6
TLD4(L/R)	65.25"	4	0.34	30.2	0.48	57.6	1.96	235.6
TLD6(L/R)	89.25"	5	0.68	60.4	0.48	57.6	2.87	344.2
TLM2(L/R)	41.25"	2	N/A	N/A	0.32	38.4	0.80	96.1
TLM4(L/R)	65.25"	2	N/A	N/A	0.32	38.4	1.29	154.7
TLM6(L/R)	89.25"	2	N/A	N/A	0.32	38.4	1.78	213.3

T8 Lighting with Electronic Ballasts (120 Volt)

MODEL	CASE LENGTH	CANOPY LIGHTS - PER ROW				SHELF LIGHTS - PER ROW				NOSE LIGHT		MAXIMUM LIGHTING *	
		AMPS		WATTS		AMPS		WATTS		AMPS	WATTS	AMPS	WATTS
		1 ROW	2 ROWS	1 ROW	2 ROWS	1 ROW	2 ROWS	1 ROW	2 ROWS	(5 ROWS)	(5 ROWS)		
TL(D/M)2(L/R)	41.25"	0.20	0.30	24.0	36.0	0.20	0.30	24.0	36.0	0.20	24.0	0.80	96.0
TL(D/M)4(L/R)	65.25"	0.30	0.40	36.0	48.0	0.30	0.40	36.0	48.0	0.40	48.0	1.20	144.0
TL(D/M)6(L/R)	89.25"	0.35	0.50	42.0	60.0	0.35	0.50	42.0	60.0	0.50	60.0	1.50	180.0

* For cases with 2 rows of canopy lights and 2 rows of shelf lights. Mezzanine shelves are only approved for TLD cases.

Defrost Data:

DEFROST TYPE	DEFROSTS PER DAY	DURATION TIME (MIN)	TERMINATION TEMP. (°F)	BACKUP PRESSURE SETTINGS *		EPR SETTINGS **		DEFROST WATER (LB / FT / DAY)
				CUT IN	CUT OUT	R22 (PSIG)	R404A (PSIG)	
TIME OFF - TLD Miters	4	34	N/A	50# @ R22	31# @ R22	36	47	0.90 lb
TIME OFF - TLM Miters	2	54	N/A	50# @ R22	31# @ R22	36	47	0.82 lb ***

* Used with electronic thermostat and EPR control. ** Set EPR to give this pressure at the case.

*** On TLM units, there is a moisture loss equal to 1.74 oz / ft² / 24hrs

CASE-TO-CASE SUCTION LINE SUB-FEED BRANCH SIZING FOR CASE LINE-UPS (R-22 REFRIGERANT)

MODEL	4'	6'	8'	12'	16'	20'	24'	28'	32'	36'	40'	44'	48'	52'	56'
TLD	3/8	3/8	1/2	1/2	5/8	5/8	5/8	5/8	7/8	7/8	7/8	7/8	7/8	7/8	7/8
TLM	3/8	3/8	3/8	1/2	1/2	1/2	5/8	5/8	5/8	5/8	5/8	7/8	7/8	7/8	7/8

CONVENIENCE OUTLET CIRCUIT: One single convenience outlet is on the back of the 2', 4' and 6' miter cases. Plan suitable 15A circuits for these 120V outlets.

A suction stop evaporator pressure regulator along with an electronic thermostat should be installed on each system to aid in temperature control. Set the EPR for 36 PSIG (R22).

Shelves are not recommended in gravity coil cases since they disrupt airflow and can compromise performance. Blower style cases may use shelving. On TLD for merchandising with two rows of shelves, the top of each shelf bracket should be mounted in the 7th and 15th slot from the top in the uprights.

Pressure control settings shown in the above table are for backup purposes only. The actual temperature control should be set by the thermostat. TLM setting for this case = CUT IN @ 26°F and CUT OUT @ 22°F. TLD setting for this case = CUT IN @ 26°F and CUT OUT @ 22°F. For merchandising using well only on the TLD, set CUT IN @ 33°F and CUT OUT @ 29°F and set defrost for 4 @ 26 minutes each.

The information contained herein is based on technical data and tests that we believe are reliable, and is intended for use by persons having technical skill at their own discretion and risk. Since conditions of use are outside of Tyler's control, we cannot assume any liability for results obtained or damages incurred through the applications of the data presented. SPECIFICATIONS ARE SUBJECT TO CHANGE WITHOUT NOTICE.

NSF CERTIFIED to meet ANSI/NSF – 7. CASE BTUH REQUIREMENTS are calculated to produce approximately the indicated performance with absolute maximum operating ambient limits of 75°F & 55RH.

TLD MITER CROSS SECTION

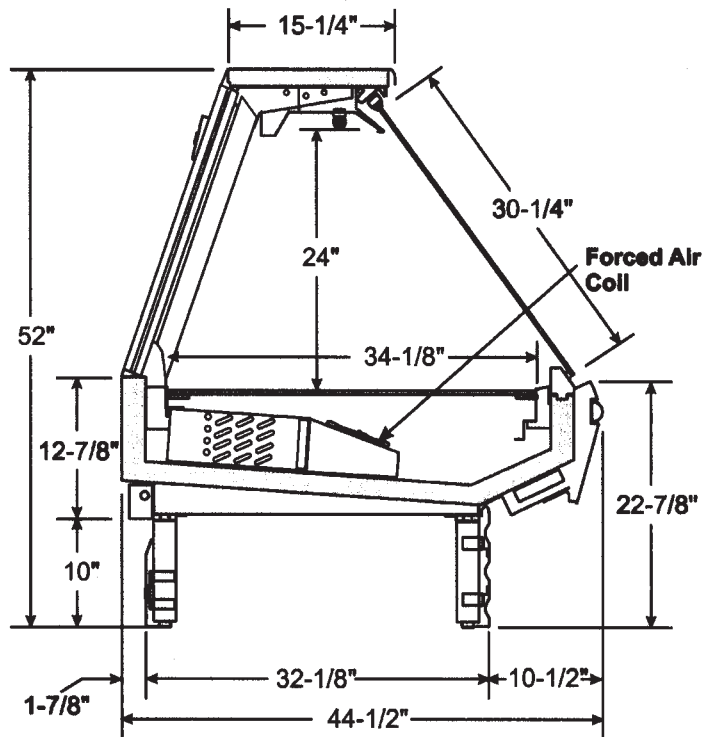

TLM MITER CROSS SECTION

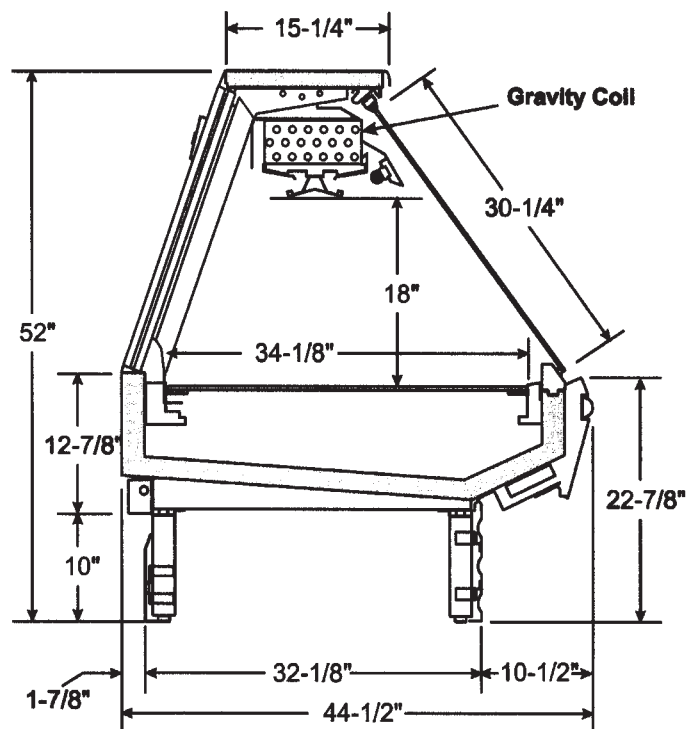

TL(D/M)2R / TL(D/M)2L MITER FLOOR PLANS

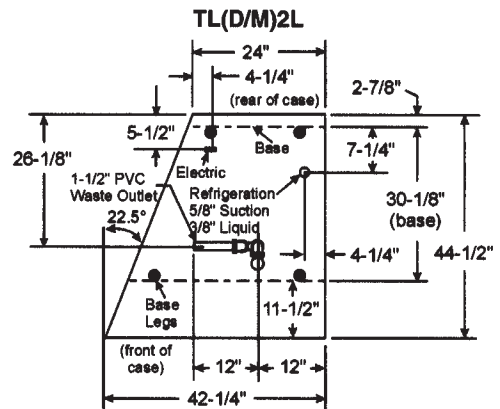
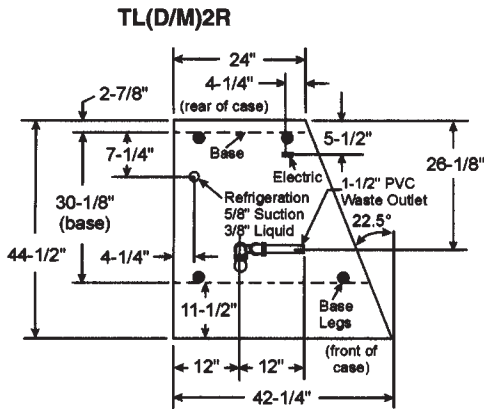

TL(D/M)4R / TL(D/M)4L MITER FLOOR PLANS

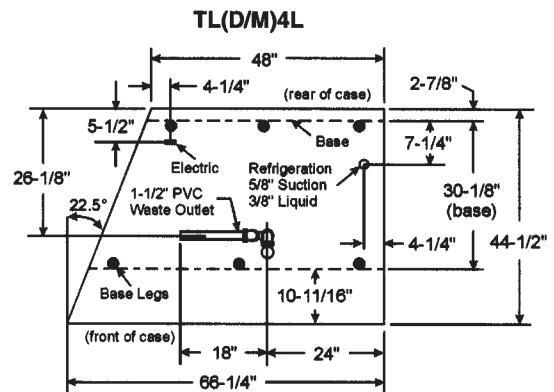
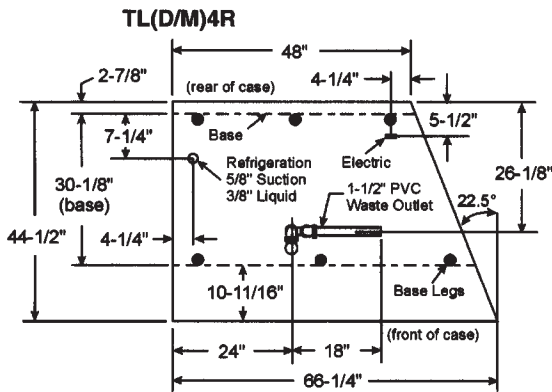

TL(D/M)6R / TL(D/M)6L MITER FLOOR PLANS

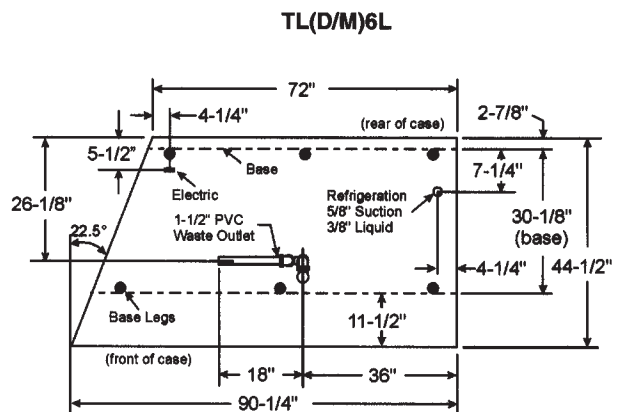
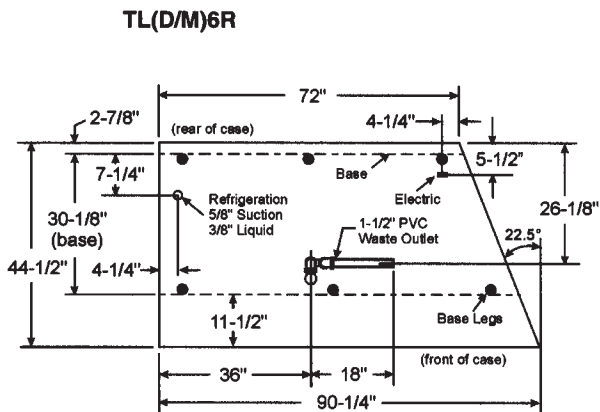

Pre-Installation Check List**WARNING**

These cases are very heavy and require two or more people to unload, move, position and/or install them. Improper handling of these cases could result in personal injury.

NOTE:

Cases with legs are shipped to stores on skids under the base frame. Cases should be unloaded and moved by one of the conventional methods

All cases containing glass MUST be stored and installed on level surfaces to avoid possible product damage and/or glass breakage.

1. Check for hidden damage while unloading and unpacking of the case.
2. Check the "shipped loose" parts for any items; such as legs, shelves, nuts and bolts, caulking, access doors, etc.
3. Check the equipment - remove the screws used to hold down the deck pans during shipping. Remove the pans and check the following, if applicable:
 4. Remove all packing material.
 5. Check all flare nut connections for tightness.
 6. Check all fan bracket bolts for tightness.
 7. Check all electrical plug-in connections for positive seal.
 8. Make sure the expansion valve feeler bulb is securely attached to the suction line.
 9. All field wiring and plumbing MUST conform to national, state, and local codes.
 10. Do not remove plugs (from flare nuts) or caps (from threaded connections) until the unit is ready for final hook-up. All coils are pressurized and have a Schrader Valve access fitting. If pressure has been lost, check for leaks.

INSTALLATION PROCEDURES**WARNING**

The raised front glass projects in front of the case and could cause personal injury to workers, operators and/or customers.

- Do not remove orange warning tags from front edge of lift glass.
- Do not leave lift glass raised and unattended.
- Know where the front edge of the raised glass is when working near it.

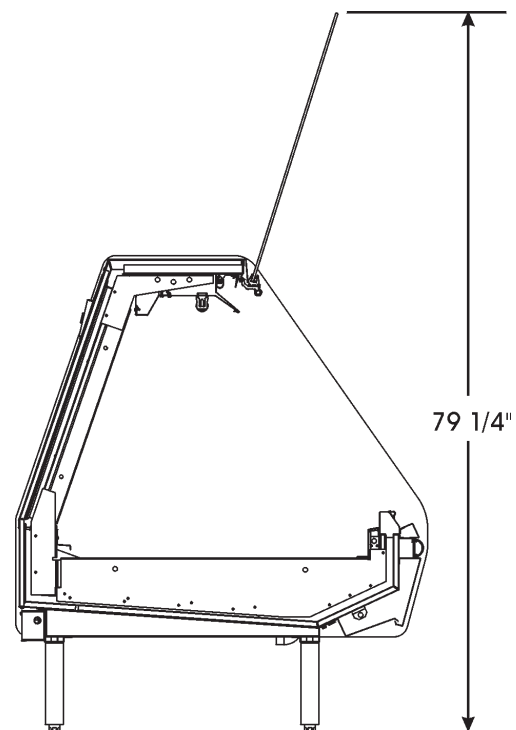

This case is designed so the front glass can be raised for cleaning and merchandising only. It is recommended that any cleaning or merchandising be done when the store is closed. If this is not possible, it should be done at a time when customer traffic is low.

The raised glass should not be left unattended and should be lowered whenever leaving the case.

The glass front is marked with orange warning tags to make it noticeable when in the raised position. **Do not remove the orange tags.**

Carpentry Procedures

Case Line-Up

Before starting the case line-up, review the store layout floorplans and survey the areas where case line-ups are going to be installed.

WARNING

- **These cases are very heavy and require two or more people to move, position and/or install them.**
- **Do not walk on the tops of these cases. Tops of cases are not designed to support the weight of a human being.**

Improper handling of these cases could result in personal injury.

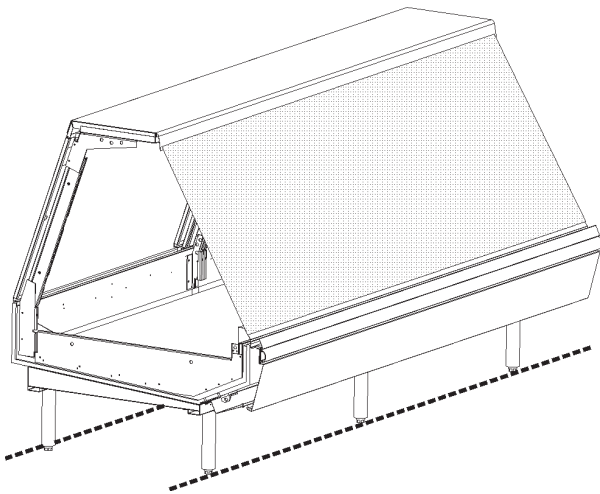

1. Snap chalk lines where the front and rear of the case legs are to be located for the entire line-up.

NOTE

Front and rear edges of legs should always be used to line-up cases. Cases with legs have built-in leveling adjustment capabilities.

2. Cases are shipped on skids. Using a proper lifting device, lift case off skid and position case where it is to be installed. While the case is properly supported, install legs into threaded holes in base. Make sure all legs are completely threaded into the base to properly secure them. Carefully lower case until it is supported by the legs. Thread out bottom leg insert, up to 1 1/2", to level the case.

Check leveling across the top of the case and on top of the front cladding.

CAUTION

If the base of this case is not sitting evenly on the floor, the case could warp when loaded and possibly break the lift glass.

NOTE

A foam gasket is factory installed on one end of the case. This gasket fits into a groove on the adjoining case when cases are pulled together. Do not depend on the foam gasket alone to make a good seal!

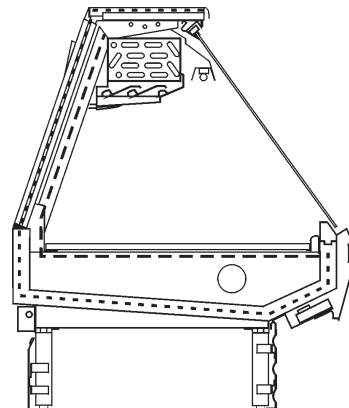

3. Apply two heavy beads of caulking compound from the Filler Kit to the end of case at dotted (. . .) and dashed (- - -) lines. Proper caulking provides good case refrigeration and sanitation.

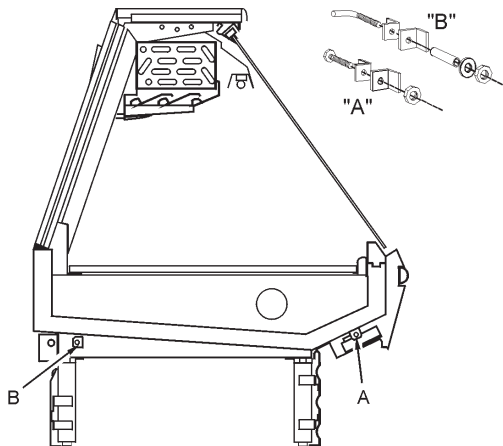

4. Push cases tightly together making sure the pull-ups are aligned.
5. Adjust legs as required. Check leveling at top of the case and on top of the front cladding.

CAUTION

Do not drill or use other holes through the case end for pull-ups. This may deform the case end and could cause joint leaks and/or poor refrigeration.

6. Position pull-up bolts and mounting hardware at pull-up locations (A and B). Do not tighten any pull-up hardware until all of it has been installed. Tighten all pull-up hardware equally starting at point A and finishing at point B. **Do not overtighten.**

Lift Front Glass Leveling Instructions

Accurate leveling is critical for the proper operation of the lift glass on this case.

In some instances, setting the case on an apparently level floor can cause the lift glass to fit improperly. If there is any twist in the body, it could cause the lift glass not to fit or work properly.

The emphasis when leveling this case must be on making sure the lift glass works and seals properly.

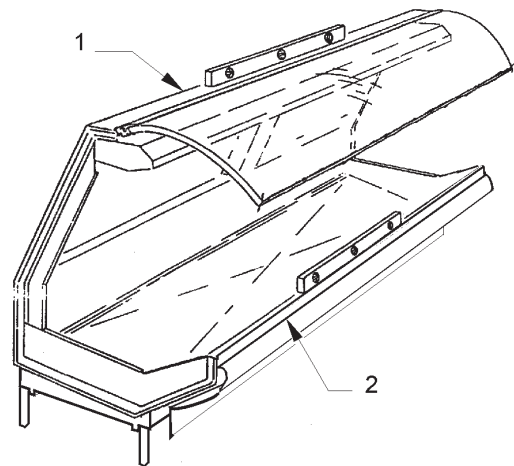

The case should be leveled across the top (1), close to the hinge, and on the top of the front cladding (2). A 4 foot level is recommended, and **both places should be level!** This will enable the lift glass to fit and work properly.

If the lift glass still doesn't close or line-up properly, adjust the legs at the case corners. Leg adjustment will ensure proper operation and alignment of the lift glass.

The bottom inside edge of the lift glass must rest evenly on the full length glass stop. The lift glass edges should lineup and the spacing between glass panels should be minimal and even. Proper lift glass sealing is essential for good product refrigeration.

NOTE

Do not enclose the case until the lift glass is fitting properly and working correctly.

Rear Rail Cover & Close-off Installation (Cases with Pipe Legs)

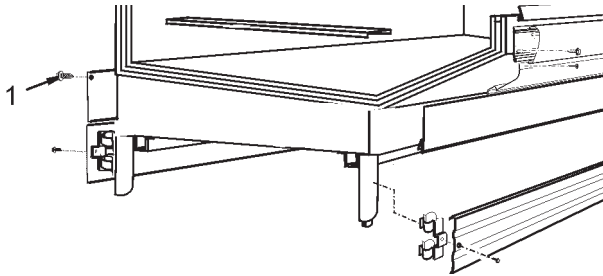

Position rear rail cover (1) over rear raceway opening and secure with screws in every hole.

Bottom and End Close-off Installation

Kickplate, optional rear bottom and end close-offs have spring clips on their back sides that secure to the pipe legs.

NOTE

Optional rear bottom close-offs do not require joint trim.

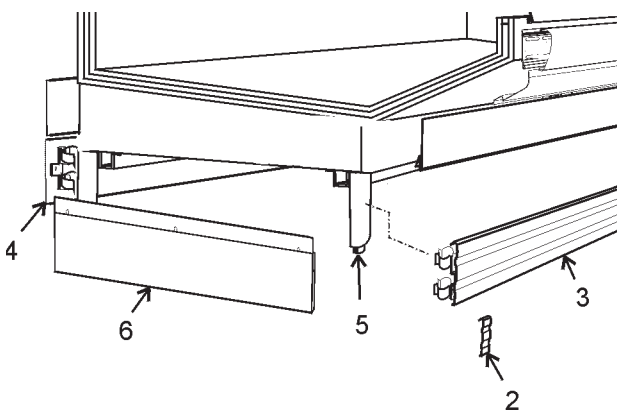

1. Before installing kickplates on a multiple case lineup, snap a joint trim (2) over the top and bottom of one of each kickplate (3).
2. Lineup each kickplate (3) and/or optional rear bottom close-off (4) and push to secure the spring clips to the legs (5).
3. Slide joint trims (2) over the case-to-case joints.
4. Position end close-offs (6) over the end of the kickplate (3) and/or optional rear bottom close-off (4) and push until the spring clips secure to the legs.

Trim Installation

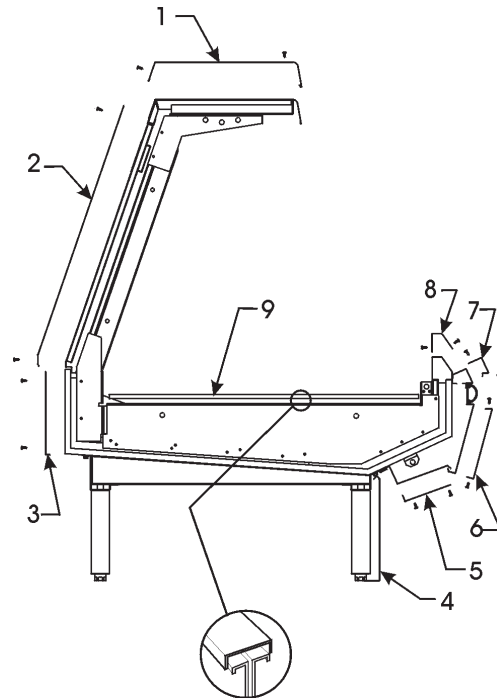

The joint trim and mounting hardware are shipped loose. Trim includes top joint trim (1), rear upper joint trim (2), rear lower joint trim (3), front kickplate joint trim (4), front lower cladding joint trim (5) and front upper cladding joint trim (6), color band backer (7), glass stop joint trim (8) and horizontal joint trim (9).

Horizontal joint trim covers gaps between the cases. The trim is glued onto the shipping cardboard. If trim has a notched side, apply trim with notched side towards front of case, after running beads of caulking on the edges of the cases. Sheet metal screws can be used for additional securing.

Patch end trim is shipped factory installed. If field installation is required, be sure the patch end is pulled up enough to fit snugly against the sealing tubing on the inside of the case. The patch end must seal tightly against the lift glass wiper to ensure proper operating temperatures.

Optional 2" Bumper Installation

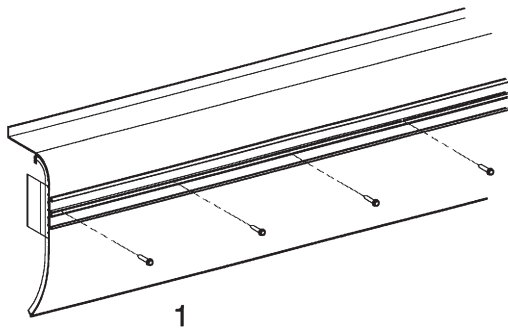

1. Install bumper retaining track on cladding with screws, if required, using same alignment as old bumper track.

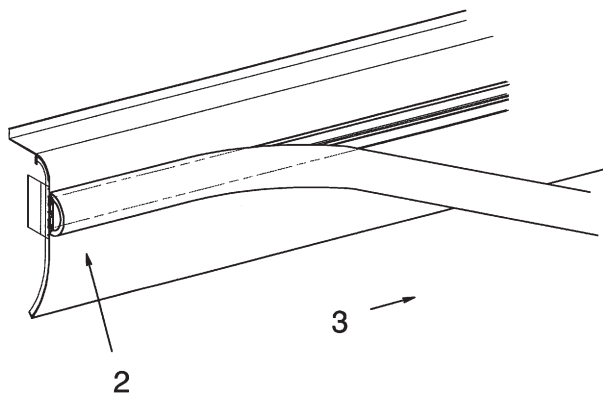

2. Cut vinyl bumper slightly longer than overall length of case line-up. Starting at either end of the case, snap end of bumper onto the bumper retainer track.
3. Curve the bumper back as illustrated. This will open the bumper and allow it to snap onto the retainer track. Working in one direction, "roll" the bumper onto the retainer track. Just before reaching the opposite end, final cut the bumper (approx. 1/8") longer than the bumper retainer. The additional 1/8" length will allow for normal shrinkage from case cooling.

NOTE

Bumper unevenness may be remedied by striking with a mallet and straight board along the length of the installation.

See "General (UL/NSF) I&S Manual" for Plumbing Procedures.

Refrigeration Procedures

Refrigeration system and superheat instructions can be found in the "General (UL/NSF) I&S Manual". Service case temperature control information is listed below.

Temperature Control

The temperature of each case is controlled with a thermostat and suction line solenoid. One thermostat and one solenoid are required for up to three cases.

The TLM(L/R) and TLD(L/R) cases use an electronic thermostat for improved temperature control.

Typical Service Case with Gravity Coil

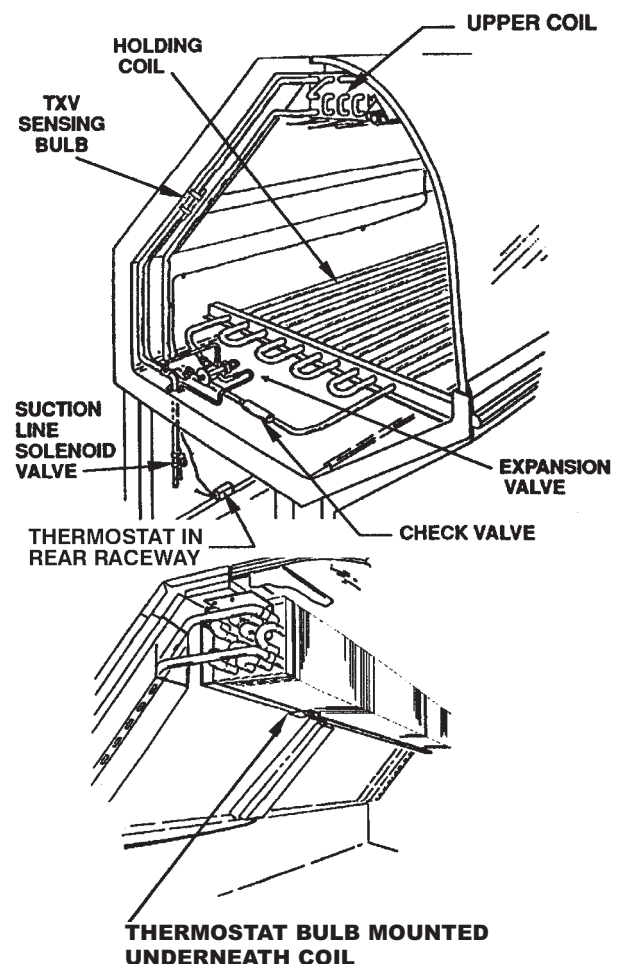

THERMOSTAT BULB PLACEMENT

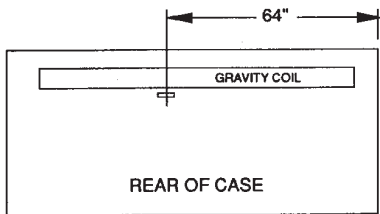

** 64" APPLIES TO 8 & 12 FOOT CASES ONLY. LOCATE APPROXIMATELY IN CENTER OF CASE FOR 6 FOOT CASES. HOOK ONTO COIL FIN GUARD AS SHOWN BELOW

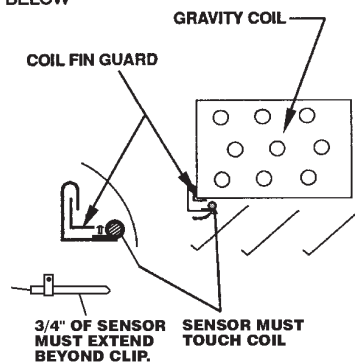

Typical Service Case with Blower Coil

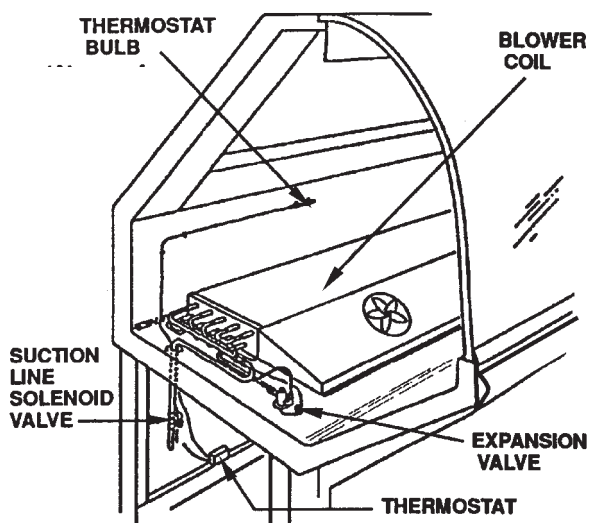

In addition to the thermostat and suction solenoid, a suction stop EPR valve is required in the suction line. The EPR valve acts as a low pressure limit to aid in the overall temperature control. See "Connecting the Refrigeration Piping and Components" on page 20 of this manual.

Setting the Electronic Thermostat

1. Remove the four screws and cover from the electronic thermostat.

2. Connect sensor wires to the common (COM) and sensor (SEN) terminals of the terminal strip located at the top left of the printed circuit board. The sensor leads are interchangeable.

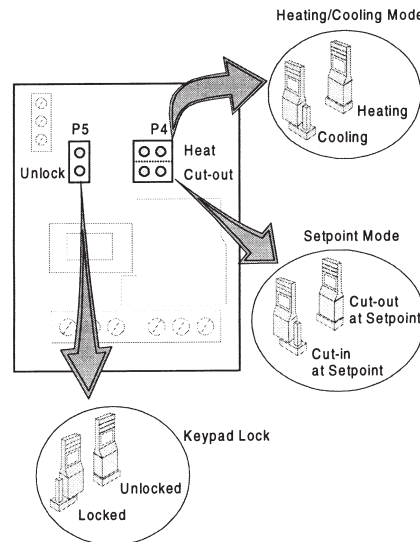

3. Set the Heating/Cooling jumper blocks to the "COOL" position.
4. Set the Cut-in at Setpoint/Cut-out at Setpoint jumper blocks to the "Cut-out at Setpoint" position.
5. Set the Keypad Locked/Unlocked jumper blocks to the "Unlocked" position.
6. Replace the electronic thermostat cover and secure with four screws.

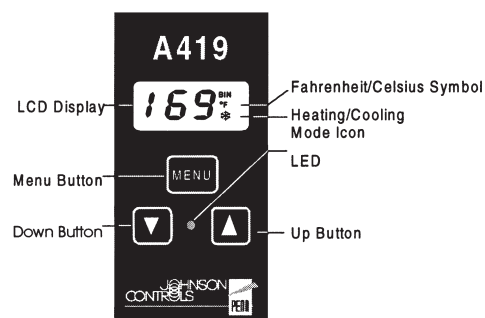

7. To adjust the setpoint:
 - a. Push the Menu Button. "SP" will flash on the LCD display.
 - b. Push the Menu Button one more time and a setpoint temperature will be displayed.

- c. Push the Up or Down Button until the desired setpoint is displayed.
(TLM(L/R) = 22°F or TLD(L/R) = 22°F)
 - d. Push the Menu Button.
8. To adjust the differential:
- a. Push the Menu Button. "SP" will flash on the LCD display.
 - b. Push the Down Button until "DIF" is shown on the LCD display.
 - c. Push the Menu Button one more time and a differential number will be displayed.
 - d. Push the Up or Down Button until the desired differential setting is displayed. (TLM(L/R) = 4°F or TLD(L/R) = 4°F)
 - d. Push the Menu Button.

With the cooling mode selected, the differential is ABOVE the setpoint. The relay will be energized and the LED indicator will illuminate when the temperature reaches the differential setting. When the temperature drops to the setpoint, the relay and LED indicator will de-energize and refrigeration will stop.

The settings above are specific to TYLER service cases. Other applications will require different setpoints and differentials.

Electrical Procedures

Electrical Considerations

CAUTION

Make sure all electrical connections at components and terminal blocks are tight. This prevents burning of electrical terminals and/or premature component failure.

NOTE

The ballast box is located at the lower left rear corner of the case. It houses ballasts and terminal blocks.

Case Fan Circuit (TLD(L/R) only)

This circuit is to be supplied by an uninterrupted, protected 120V circuit. The case fan circuit is not cycled on this case.

Ambient Fan Circuit

All TL cases have an ambient fan circuit. This circuit is supplied by an uninterrupted, protected 120V circuit. The ambient fan circuit is not cycled.

Fluorescent Lamp Circuit

TL case lighting is supplied by T-8 electronic ballast lights. It is controlled by a light switch in each case. The standard lighting is 1-row of horizontal canopy lights.

Anti-Sweat Circuit

All anti-sweat heaters are wired directly to the main power supply so they can operate at all times.

Defrost Information

See "General (UL/NSF) I&S Manual" for operational descriptions for each type of defrosty control.

Defrost Control Chart

TLM(L/R) Defrost Option Settings

Defrost			
Defrost Type	Defrosts Per Day	Duration (Min)	Term. Temp.
Off Time	2	54	-----

TLD(L/R) Defrost Option Settings

Defrost			
Defrost Type	Defrosts Per Day	Duration (Min)	Term. Temp.
Off Time	4	34	-----

Thermostat and sensor locations are shown on pages 11 and 12 of this manual.

WIRING DIAGRAMS

ELECTRICIAN NOTE - OVERCURRENT PROTECTION

120V circuits should be protected by 15 or 20 Amp devices per the requirements noted on the cabinet nameplate or the National Electrical Code, Canadian Electrical Code - Part 1, Section 28. 208V defrost circuits employ No. 12 AWG field wire leads for field connections. On remote cases intended for end to end line-ups, bonding for ground may rely upon the pull-up bolts.

The wiring diagrams on pages 14 and 15 will cover all TLM(L/R) & TLD(L/R) case circuits.

TLM(L/R) Domestic & Export (50 Hz) Case Circuits (2', 4' and 6' Miter Cases)

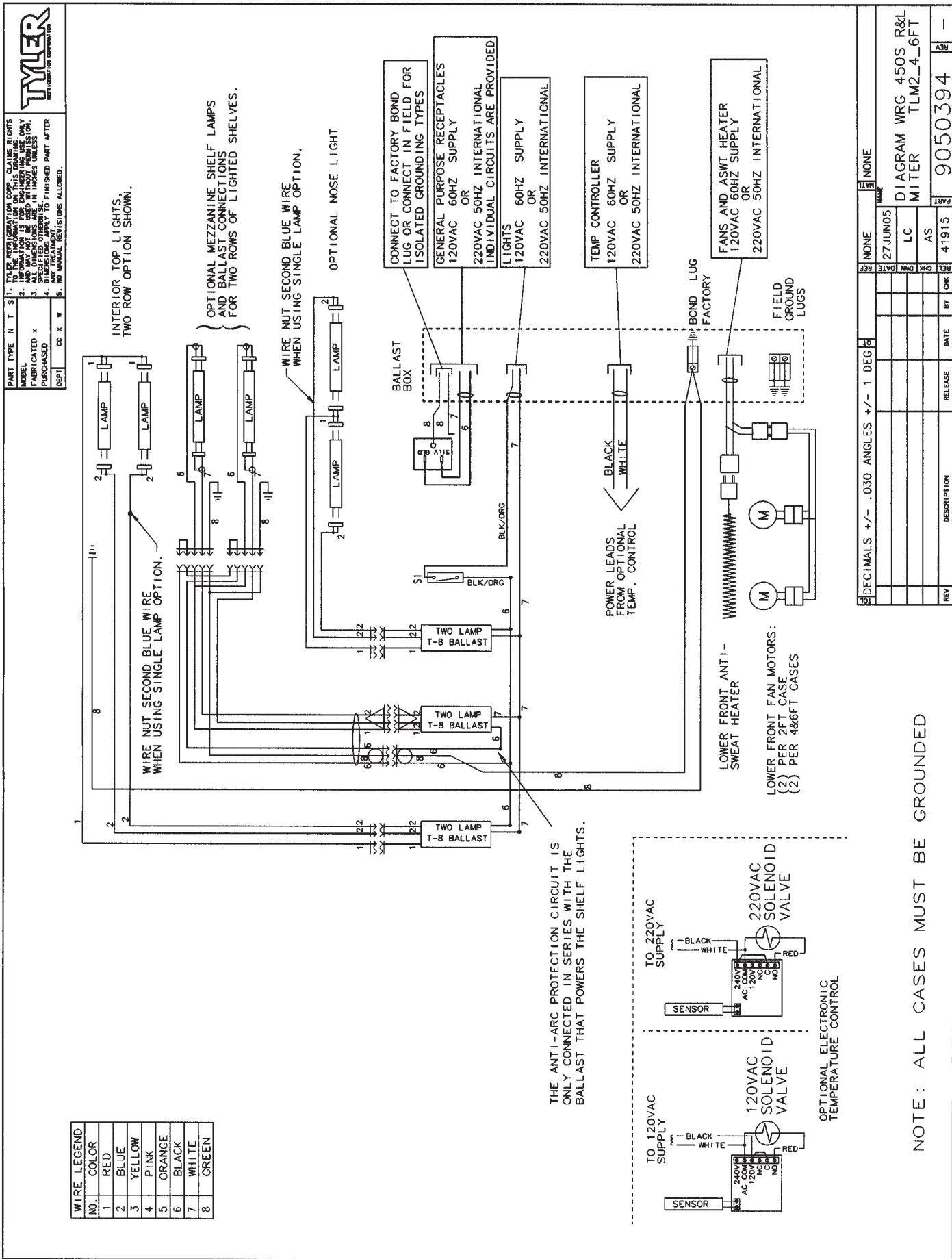

REV	DESCRIPTION	DATE	BY	CHK	APP
1					
2					
3					
4					
5					
6					
7					
8					
9					
10					
11					
12					
13					
14					
15					
16					
17					
18					
19					
20					
21					
22					
23					
24					
25					
26					
27					
28					
29					
30					
31					
32					
33					
34					
35					
36					
37					
38					
39					
40					
41					
42					
43					
44					
45					
46					
47					
48					
49					
50					
51					
52					
53					
54					
55					
56					
57					
58					
59					
60					
61					
62					
63					
64					
65					
66					
67					
68					
69					
70					
71					
72					
73					
74					
75					
76					
77					
78					
79					
80					
81					
82					
83					
84					
85					
86					
87					
88					
89					
90					
91					
92					
93					
94					
95					
96					
97					
98					
99					
100					

NOTE: ALL CASES MUST BE GROUNDED

CLEANING AND SANITATION

Component Removal and Installation Instructions for Cleaning

Lower Trays and Screens

1. Open the front straight glass by lifting the handle at the bottom.
2. Remove product from the case interior.
3. Grasp and lift out each lower tray or screen from the bottom of the case.
4. After cleaning, replace in reverse order.

Front Air Ducts

1. Remove lower trays or screens, see this page.
2. Lift out front air duct sections.
3. After cleaning, replace in reverse order.

Rear Air Ducts

1. Remove lower trays or screens, see this page.
2. Remove mounting screws from rear air duct.
3. Lift out rear air duct sections.
4. After cleaning, replace in reverse order.

Mullion Covers

1. Open the front straight glass by lifting the handle at the bottom.
2. Remove mounting screws from each mullion cover.

WARNING

Mullion covers with electrical receptacles can be cleaned without removing the electrical receptacles. Do not get moisture on electrical wires when cleaning under this cover. Moisture on wires could cause premature product failure and/or personal injury or death from electrical shock.

3. Carefully remove each mullion cover from the rear uprights.
4. After cleaning, replace and secure mullion covers in reverse order.

End Coil Cover (TLM(L/R) Only)

1. Open rear sliding doors at each end.
2. Remove screws and end coil covers from ends of upper coil.
3. After cleaning, replace end coil covers in reverse order.

Refrigeration Line Cover (TLM(L/R) Only)

1. Open the front straight glass by lifting the handle at the bottom.
2. Remove lower screens, see this page.
3. Remove mounting screws and refrigeration line cover.
4. After cleaning, replace in reverse order.

Electrical Cover (TLM(L/R) Only)

1. Open the front straight glass by lifting the handle at the bottom.
2. Remove lower screens, see this page.
3. Remove mounting screws and electrical cover.

WARNING

Do not get moisture on electrical wires when cleaning under this cover. Moisture on wires could cause premature product failure and/or personal injury or death from electrical shock.

4. After cleaning, replace in reverse order.

Front Lower Cladding

1. Remove front kickplate.
2. Lift and pull out front lower cladding until rear tabs clear holes in front of frame assembly. After rear tabs are clear, pull down on cladding to clear upper tabs from slots in bottom of upper front cladding and remove cladding from case.
3. After cleaning, replace front lower cladding by inserting top tabs, then rear tabs. Make sure all tabs are securely fit in each slot. Replace front kickplate.

Front Upper Cladding

1. Remove color band, bumper and bumper retainer from the case. See page 24.

2. Remove front kickplate.
3. Remove screws and front lower cladding. See page 16.
4. Remove screws from top and bottom of front upper cladding and remove front upper cladding.
5. After cleaning, replace front upper cladding and remaining front components in the reverse order.

Cleaning Instructions

WARNING

TYLER Refrigeration does not recommend the use of high pressure cleaning equipment on service style cases!! The sealing of front glass and end joints is critical in these cases and high pressure cleaners can penetrate and/or damage these seals. Damaged seals allow water leaks and/or air leaks that can cause poor case refrigeration.

CAUTION

- **When cleaning this case, try not to introduce water into the case faster than it can be carried away by the waste outlet.**
- **Liquid chlorine bleach is corrosive to metals. The use of bleach or products containing bleach will damage metal surfaces and void the case warranty.**
- **Sanitize the case with Quaternary Ammonium Solutions (ex: KAYQUAT II, J-512 Sanitizer, SANIQUAT 512, etc...) approved per 21CFR 178.1010, followed by adequate draining and air drying. These solutions may be obtained from Kay Chemical Co., Johnson Wax Professional, Coastwide Laboratories, etc....**
- **Always use a soft cloth or sponge with mild detergent and water to clean the front glass. Never use abrasives or scouring pads to clean glass. They can scratch and/or damage the glass.**

See "General (UL/NSF) I&S Manual" for case cleaning instructions.

Stainless Steel Cleaning Methods

The cleaning data in the following stainless steel cleaning chart was supplied by AISI. The information was supplied by Prime Metals Division, Alumax Aluminum Corporation.

<u>TYPE OF CLEANING</u>	<u>CLEANING AGENT*</u>	<u>APPLICATION METHOD**</u>	<u>EFFECT ON FINISH</u>
Routine cleaning	Soap, ammonia or detergent and water.	Sponge with cloth, then rinse with clear water and wipe dry.	Satisfactory for use on all finishes.
Smears and fingerprints	Arcal 20, Lac-O-Nu, Lumin Wash O'Cedar Cream Polish, Stainless Shine	Rub with cloth as directed on the package.	Satisfactory for use on all finishes. Provides barrier film
Stubborn spots and stains, baked-on splatter, and other light discolorations	Allchem Concentrated Cleaner	Apply with damp sponge or cloth.	Satisfactory for use on all finishes.
	Samae, Twinkle, or Cameo Copper Cleaner	Rub with damp cloth.	Satisfactory for use on all finishes if rubbing is light.
	Grade FFF Italian pumice, whitening or talc	Rub with damp cloth.	Use in direction of polish lines on No. 4 (polished) finish. May scratch No. 2 (mill) and No. 7 and 8 (polished) finishes.
	Liquid NuSteel	Rub with dry cloth. Use a small amount of cleaner.	Use in direction of polish lines on No. 4 (polished) finish. May scratch No. 2 (mill) and No. 7 and 8 (polished) finishes.

<u>TYPE OF CLEANING</u>	<u>CLEANING AGENT*</u>	<u>APPLICATION METHOD**</u>	<u>EFFECT ON FINISH</u>
	Paste NuSteel or DuBois Temp	Rub with dry cloth. Use a small amount of cleaner.	Use in direction of polish lines on No. 4 (polished) finish. May scratch No. 2 (mill) and No. 7 and 8 (polished) finishes.
	Cooper's Stainless Steel Cleaner, Revere Stainless Steel Cleaner	Apply with damp sponge or cloth.	Use in direction of polish lines on No. 4 (polished) finish. May scratch No. 2 (mill) and No. 7 and 8 (polished) finishes.
	Grade F Italian pumice, Steel Bright, Lumin Cleaner, Zud or Restoro	Rub with a damp cloth.	Use in direction of polish lines on No. 4 (polished) finish. May scratch No. 2 (mill) and No. 7 and 8 (polished) finishes.
	Penny-Brite or Copper-Brite	Rub with a dry cloth. Use a small amount of cleaner.	Use in direction of polish lines on No. 4 (polished) finish. May scratch No. 2 (mill) and No. 7 and 8 (polished) finishes.
Heat tint or heavy discoloration	Penny-Brite or Copper-Brite	Rub with a dry cloth.	Use in direction of polish lines on No. 4 (polished) finish. May scratch No. 2 (mill) and No. 7 and 8 (polished) finishes.
	Paste NuSteel or DuBois Temp	Rub with dry cloth. Use a small amount of cleaner.	Use in direction of polish lines on No. 4 (polished) finish. May scratch No. 2 (mill) and No. 7 and 8 (polished) finishes.
	Revere Stainless Steel Cleaner	Apply with a damp sponge or cloth.	Use in direction of polish lines on No. 4 (polished) finish. May scratch No. 2 (mill) and No. 7 and 8 (polished) finishes.
	Allen Polish, Steel Bright, Wyandotte, Bab-O or Zud	Rub with a damp cloth.	Use in direction of polish lines on No. 4 (polished) finish. May scratch No. 2 (mill) and No. 7 and 8 (polished) finishes.
Burnt-on foods and grease, fatty acids, milkstone (where swabbing or rubbing is not practical)	Easy-Off, De-Grease-It, 4-6% hot solution of such agents as trisodium tripolyphosphate, or 5-15% caustic soda solution	Apply generous coating. Allow to stand for 10-15 min. Repeated application may be necessary.	Excellent removal, satisfactory for use on all finishes.
Tenacious deposits, rusty discolorations, industrial atmospheric stains	Oakite No. 33, Dilac, Texo 12, Texo N.Y., Flash-Klenz, Caddy Cleaner, Turco Scale 4368 or Permag 57.	Swab and soak with clean cloth. Let stand 15 minutes or more according to directions on package. Rinse and dry.	Satisfactory for use on all finishes.
Hard water spots and scale	Vinegar	Swab or wipe with a cloth. Rinse with water and dry.	Satisfactory for use on all finishes.
	5% oxalic acid, 5% sulamic acid, 5-10% phosphoric acid, or Dilac, Oakite No. 33, Texo 12 or Texo N.Y.	Swab or soak with a cloth. Let stand 10-15 minutes. Always follow with neutralizer rinse, and dry.	Satisfactory for use on all finishes. Effective on tenacious deposits or where scale has built up.

<u>TYPE OF CLEANING</u>	<u>CLEANING AGENT*</u>	<u>APPLICATION METHOD**</u>	<u>EFFECT ON FINISH</u>
Grease and oil	Organic solvents such as carbon tetrachloride, trichlorethylene, acetone, kerosene, gasoline, benzene, alcohol and chlorethane n.u.	Rub with a cloth. Organic solvents may be flammable and/or toxic. Observe all precautions against fire. Do not smoke while vapors are present. Be sure area is well ventilated.	Satisfactory for use on all finishes.

* Use of proprietary names is intended only to indicate a type of cleaner, and does not constitute an endorsement, nor is omission of any proprietary cleanser to imply its inadequacy. It should be emphasized that all products should be used in strict accordance with instructions on package.

** In all applications a sponge or fibrous brush or pad are recommended. DO NOT use of ordinary steel wool, steel brushes, chlorine bleach or products containing bleach for cleaning or sanitizing stainless steel.

GENERAL INFORMATION

Rear Sliding Door Removal and Installation

The sliding doors come installed from the factory in the door frames. These doors are removable for cleaning and to aid in case maintenance. **NOTE: DO NOT FULLY IMMERSE DOORS WHEN CLEANING.** The inner and outer doors are marked with labels from the factory. If the doors are not labeled, the inner door can be identified as having the limiter stops on it.

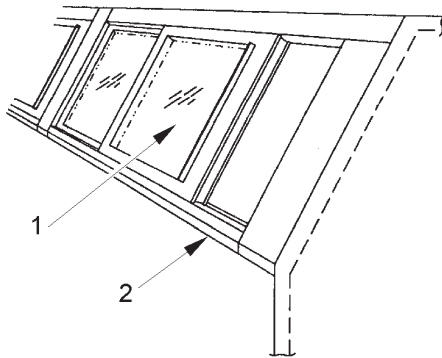

1. Remove the outer door (1) by sliding it to the right end of the door frame (2) (within an inch of being closed).

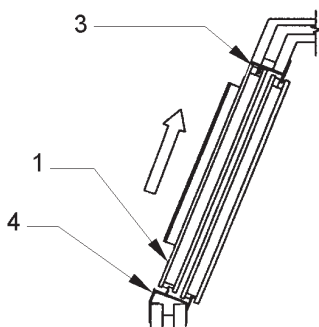

2. Firmly grasp both sides of the outer door (1) and lift into the upper track (3) until it clears the lower track (4).

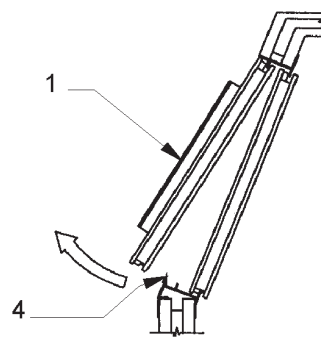

3. Tilt out the bottom of the outer door (1) so it can clear the lower track (4).

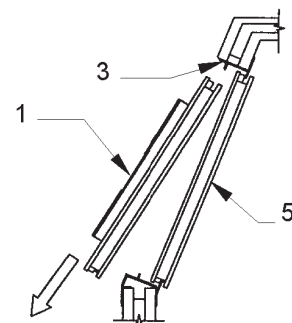

4. Lower the outer door (1) out of the upper track (3) to remove it from the case.
5. Repeat steps 1 thru 4 to remove the inner door (5).
6. Reverse the above steps to replace the inner and outer doors (5 and 1).

Mezzanine Shelving

Mezzanine shelves are available in 10" or 12" widths. One level of shelving is optionally available for TLM(L/R) cases, while two levels of shelving is available for TLD(L/R) cases. The shelves can be moved forward from the mullions in two inch increments and can be locked into three positions.

Price tag moldings will be attached to the front of each mezzanine shelf with screws. To clean the price tag molding, remove screws and molding from shelves. After cleaning, reattach molding to shelves with screws.

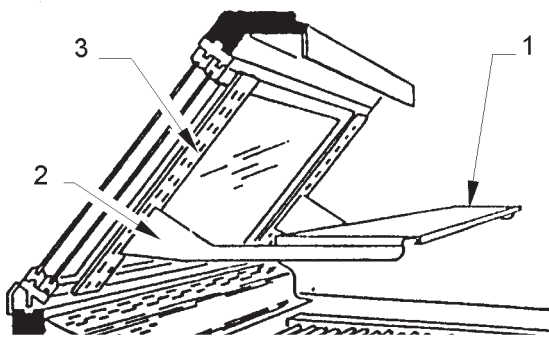

To install mezzanine shelving, position and insert the mezzanine shelf (1) and captive shelf brackets (2) into slots in the uprights (3).

NOTE

The brackets can be moved vertically at 1" increments in the uprights.

Lighted Shelves

Lights are optional on the 10" and 12" mezzanine shelves. Wiring harnesses for all shelf locations are factory installed. Ballasts are optionally supplied for all shelf light sockets. The ballasts are located in the rear raceway channel behind the rear rail cover.

SERVICE INSTRUCTIONS

Connecting the Refrigeration Piping and Components

WARNING

Be sure to position a flame and heat-resistant shield over the bottom of the case liner. Heat from brazing could damage the liner and/or cause personal injury or death from fire.

1. Remove screws and refrigeration piping cover from the left bottom of the case.
2. Position loose refrigeration piping and/or optional valves between the open lines in the bottom and upright of the case.

NOTE

- **Make sure all sensor and thermostat wires are clear of areas being heated.**
 - **Mount all refrigeration lines off the floor to allow for cleaning access.**
3. Apply flux to all joint ends. Starting at one end, thoroughly heat each new pipe joint and braze it together. Repeat this process until all new pipe joints have been brazed.
 4. After piping has cooled, route and connect thermostat and sensor wires through openings in the bottom of the case.

Light Servicing

See "General (UL/NSF) I&S Manual" for preventive maintenance, T-8 lamp, fan blade and fan motor (TLD(L/R)) replacement instructions.

Ballast and Lighting Locations

All light ballasts are located in the rear raceway channel behind the rear cover.

In order to retain safety approval with Underwriter's Laboratory and the Canadian Standards Association, the mounting of electrical components and interconnecting wires must not deviate from the following instructions. Only qualified personnel are authorized to install the accessory items. TYLER Refrigeration recommends you order all components from its Service Parts Department.

Ballast Replacement

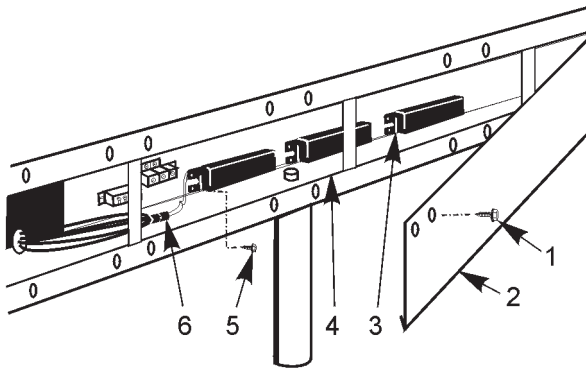

1. Remove screws (1) and rear rail cover (2) from rear of case.

NOTE

If tappit screws are not available, a star-washer should be used between the ballast and the heads of the screws.

2. Install required number of ballasts (3) in rear electrical raceway (4) with two screws (5) each.
3. Identify and connect required wiring harnesses (upper, lower, etc...) to the ballast connectors (6).
4. Replace rear rail cover (2) and secure with screws (1).

Front Glass Anti-Fogging System Service

TLM(L/R) and TLD(L/R) cases have a front glass anti-fogging fan and a front glass anti-sweat heater. Use the following instructions to replace the anti-sweat heater and/or the anti-fogging fan.

WARNING

Shut off or disconnect power supply to case before replacing any part of the anti-fogging system. Electrical power from wire ends could damage other components and/or cause personal injury or death.

Front Glass Anti-Sweat Replacement

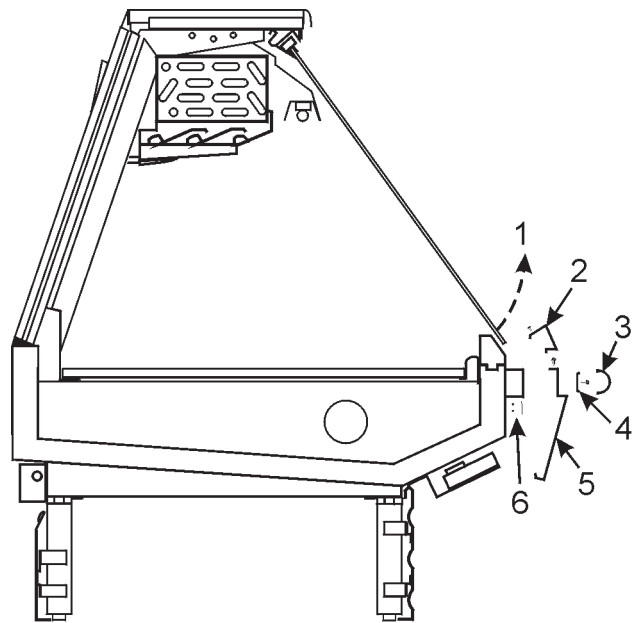

1. Lift and open front lift glass.
2. Remove two screws and color band from case.
3. Remove bumper from bumper retainer.
4. Remove mounting screws and bumper retainer from front of case.
5. Remove mounting screws and front upper cladding from front of case.

6. Note position of old heater wire and foil tape. Unplug heater wire from harness connector and remove foil tape and heater wire. Install new heater wire and foil tape in same position as removed.
7. Plug-in the new heater wire at the harness connector.
8. Reinstall front cladding, bumper components and color band in reverse order.

Front Glass Anti-Fog Fan Replacement

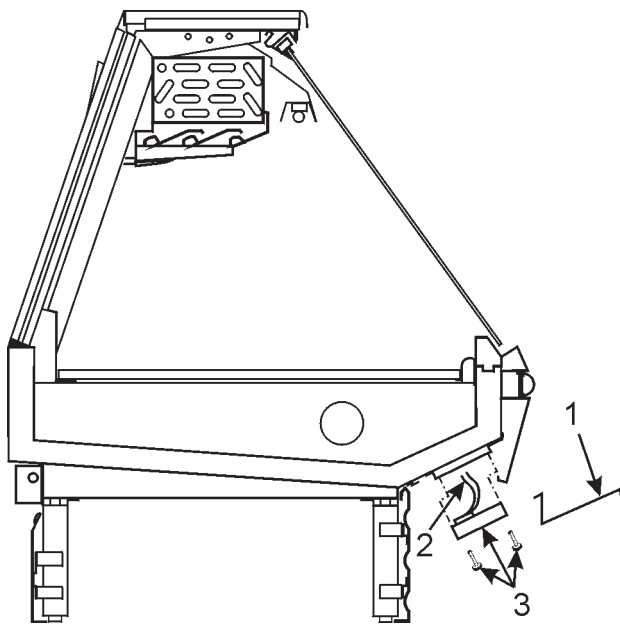

1. Lift and tilt out the lower front cladding to remove from front of case.

NOTE

The bottom of the front upper cladding may have to be pulled out slightly to access the top fan mounting screws.

2. Disconnect defogger fan power cord.
3. Remove four screws and defective fan from fan brackets.
4. Install new defogger fan on fan brackets and secure with four screws. Reconnect the defogger fan power cord.
5. Reinstall the lower front cladding.

Lift-Glass Replacement

WARNING

Wear safety glasses and gloves and use at least two people when replacing glass. Glass is heavy and weight distribution is uneven. Mishandling of glass could cause breakage and/or personal injury.

If replacing glass:

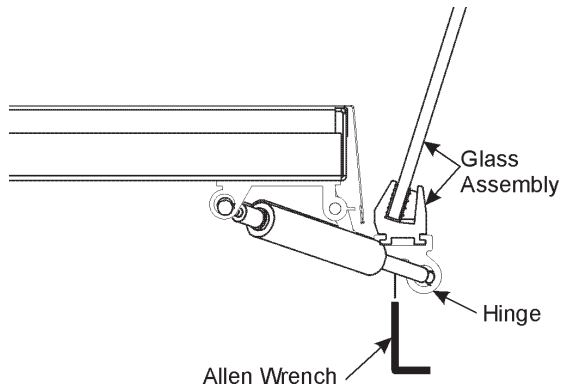

1. Raise the old glass to the full UP position.

NOTE

Glass is heavy and requires assistance for properly support.

2. With assistants firmly holding both ends of the glass, loosen the set screws on the bottom of each hinge with an allen wrench. After set screws are loosened, slide old glass assembly to right or left to remove from hinges.

NOTE

Note positioning and installation of top edge channel before removing.

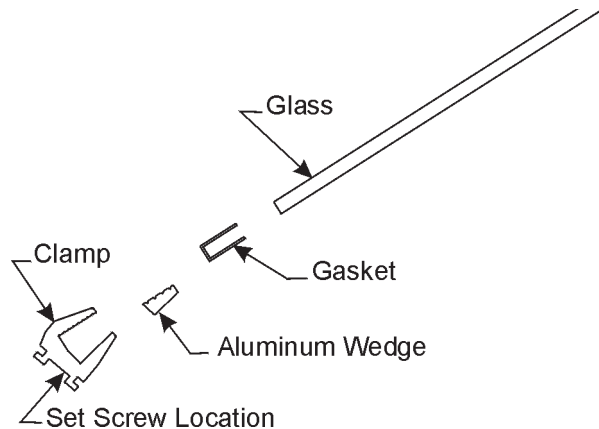

3. Loosen set screws in back of top edge channel.
4. Using a flathead screwdriver, push down aluminum wedge inside top edge channel, until it rests in bottom of the channel. After wedge has been released from glass, remove the old glass from the top edge channel.
5. Position the top edge channel on the new glass panel in same position as removed.

NOTE

Glass must be fully inserted into top edge channel before tightening.

6. After glass is positioned in the top edge channel, tighten each set screw until glass is held into place by the aluminum wedge. **Do not overtighten.**
6. With aid of assistants, lift and tentatively position new glass assembly in the hinge slots. Tighten the hinge set screws. **Do not overtighten.**
7. Slowly lower glass to check position. If adjustment is necessary, raise glass and have assistants hold both ends. Loosen the hinge set screws, adjust the glass assembly position and retighten set screws to secure top edge channel in hinge slot. **Do not overtighten.**

Lift-Glass Gas Piston Replacement

WARNING

The TL series cases rely upon gas pistons to assist lifting the glass and holding it in the raised position. The glass is heavy and difficult for one person to lift alone while replacing a gas piston. Use an assistant to prevent possible glass breakage and/or personal injury.

Since gas pistons are very powerful when in compressed state, follow these cautions during replacement:

- Do not attempt to perform any work on case while piston is in compressed state.
- Raise glass to full UP position before beginning any work involving gas pistons.
- Do not attempt to alter a gas piston in any way.
- Do not expose a gas piston to excessive heat.
- Dispose of gas piston as soon as possible after removal.

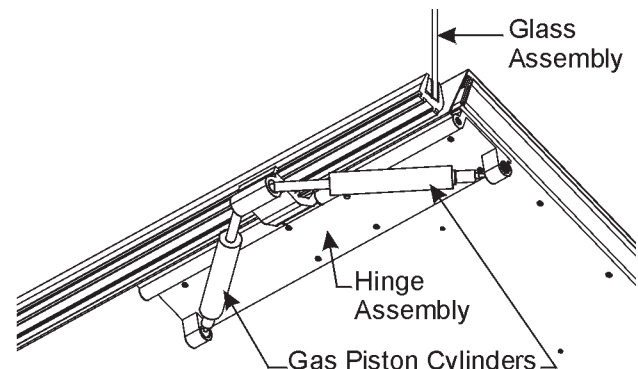

Each lift glass panel uses four gas pistons and two hinges to support it. **Example:** TLM6(L/R) cases have 2 lift glass panels with 4 hinges and 8 gas pistons.

1. Have an assistant lift and hold the glass in the full UP position. **Note position and relationship of all glass lift components.**

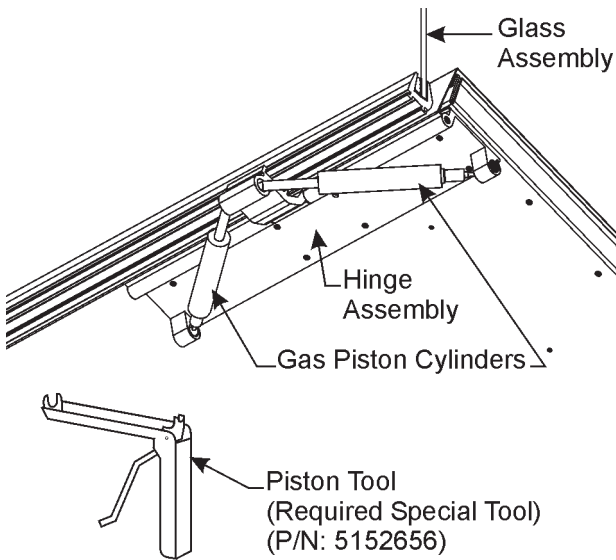

2. While lift glass is being held open, position gas piston in piston tool and squeeze tool to compress and remove the old gas piston.
3. Install new gas piston on lift glass hinges using the piston tool. Note weight capacity printed on side of piston, **example: 0500N (500 Newton)**. Replacement piston should be of same weight capacity as the piston being replaced.
4. Repeat steps 2 and 3 until all bad gas pistons have been replaced.

Color Band, Bumper and Bumper Retainer Replacement

NOTE

Color band, bumper and bumper retainer must be removed to access the upper screws in the front upper cladding.

1. Open the lift glass and remove screws, color band and color band backers from bottom glass support.
2. Push in on center of bumper while pulling out on bottom of bumper. This will start to separate bumper from bumper retainer.
3. Make sure the bottom of the bumper is released from the bumper retainer for the full length of the case.
4. After bottom is released, firmly pull out top of bumper to snap it free from bumper retainer.
5. Remove bumper backers from both ends of the bumper
5. Mark position of the bumper retainer on front of case.
6. Remove mounting screws and bumper retainer from front of case.

NOTE

Bumper backer and color band backer must be installed in same position as removed to assure proper fit and alignment during installation.

7. Install bumper retainer on front of case with mounting screws in same position as removed.
8. Position bumper backers in ends of bumper sections still installed, so half of the bumper backers are still exposed.
9. Replace the bumper on the bumper retainer.
10. Position color band backers under ends of color bands still installed, so half if the color band backer is still exposed.
11. Replace color band on bottom glass support and secure with screws.

Anti-Sweat Heater Wire Deflector Kit Replacement (TLD4(L/R)/TLD6(L/R))

TLD4(L/R) & TLD6(L/R) Miter models have anti-sweat heaters under each lower rear door frame. Use these instructions to replace an anti-sweat heater wire deflector kit.

WARNING

Shut off or disconnect power supply to case before replacing any part of the anti-sweat heater wire deflector kit. Electrical power from wire ends could damage other components and/or cause personal injury or death.

1. Remove product from case.
2. Remove rear doors from door frame that has defective anti-sweat wire. (See page 19 in this manual.)
3. Remove screws and door frame from rear of case.

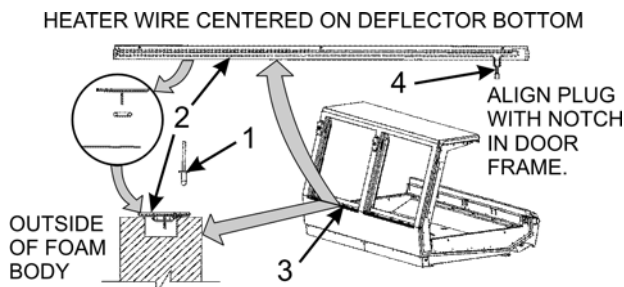

4. Drill out three rivets (1) securing the anti-sweat heater wire deflector kit (2) to the bottom of the door opening (3).
5. Unplug or cut wires to anti-sweat heater wire (4) and remove defective deflector kit (2) from case.
6. Install new anti-sweat heater wire deflector kit (2) in reverse order making sure not to pinch the anti-sweat wires (4) under the deflector plate.
7. After doors have been reinstalled, reconnect power to case. Replace product in case after operating temperature has been established in the case.

PARTS INFORMATION**Cladding and Trim Parts List**

Item	Description	2' Miter	4' Miter	6' Miter
1	Top Cladding, BRT/SS	9807244	9801096	N/A
	Top Clad. Joint Trim, BRT/SST	9807457	9807457	9807457
	Top Clad. Miter Joint Trim	9803319	9803319	9803319
2	Color Band, Ptd.	9807236	9801099	N/A
3	Color Band Joint Trim, Ptd.	9801776	9801776	9801776
	Color Band Miter Joint Trim, Ptd.	9803316	9803316	9803316
4	Bumper Retainer, Std.	9803309	9801104	N/A
5	Screw	5183536(8)	5183536(12)	5183536(16)
6	Bumper, Std. 2"	9807246	9801094	N/A
7	Upr. Frt. Cladding, Ptd. Std.	9807220	9801097	N/A
	Screw	5183536(6)	5183536(8)	5183536(9)
8	Upr. Frt. Clad. Joint Trim Std.	9801811	9801811	9801811
	Upr. Frt. Clad. Miter Joint Trim	9803317	9803317	9803317
	Screw	9024814(4)	9024814(4)	9024814(4)
9	Rt. Miter Kickplate Assy., Std.	9807259	9804779	N/A
	Lt. Miter Kickplate Assy., Std.	9807260	9804778	N/A
	Frnt. Kickplate Assembly, Opt.	9807475	9807474	N/A
10	Kickplate Joint Trim, Std	9807539	9807539	9807539
	Kickplate Joint Trim, Opt.	9803245	9803245	9803245
	Screw	5619204(4)	5619204(4)	5619204(4)
11	Lwr. Frt. Cladding, Std. Ptd.	9807228	9801101	N/A
12	Lwr. Frt. Cladding Joint Trim	9803318	9803318	9803318
	Screw	9024814(4)	9024814(4)	9024814(4)
13	Pipe Leg, Std. (1.75" X 9.75")	9024894(4)	9024894(6)	9024894(6)
	Pipe Leg, Opt. (1.75" X 6.00")	9024893(4)	9024893(6)	9024893(6)
14	Horizontal End Trim	9037279	9037279	9037279
15	Glass Bumper	9801304	9801304	N/A
	Glass Stop Miter Joint Trim, Ptd.	9803320	9803320	9803320
16	Base End Close-off, Ptd. (per patch end)	9801852	9801852	9801852
	Opt. Base End Close-off, Ptd. (per patch end)	9803177	9803177	9803177

Item	Description	2' Miter	4' Miter	6' Miter
17	Raceway Cover, Ptd.	9803307	9801111	N/A
	Screw	9043080(5)	9043080(5)	9043080(10)
18	Lwr. Rear Joint Trim, Ptd.	9804723	9804723	9804723
	Screw	9024814(4)	9024814(4)	9024814(4)
19	Upr. Rear Joint Trim, Ptd.	9804727	9804727	9804727
	Screw	9024814(4)	9024814(4)	9024814(4)
20	Rear Cladding, Ptd.	9803355	9802484	N/A
	Screw	9024814(4)	9024814(4)	9024814(4)
21	Rear Miter Cladding, Ptd.	N/A	9807536	N/A
	Screw	9024814(4)	9024814(4)	9024814(4)
22	Rear Mullion Cladding, Ptd.	N/A	9807532	N/A
	Screw	9024814(4)	9024814(4)	9024814(4)
23	Rear Liner Miter Joint Trim	9804703	9804703	9804703
	Screw	5199134 (4)	5199134(4)	5199134(4)
24	Top Liner Joint Trim	9804705	9804705	9804705
	Screw	5199134 (4)	5199134 (4)	5199134 (4)
25	Light Shield Miter Joint Trim	9807421	9807421	9807421
26	Refrig. Line Cover (TLM(L/R)) (Not Shown)	9024864	9024864	9024864

Operational Parts List

Case Usage	Domestic		
Electrical Circuit	115 Volt 60 Hertz		
Case Size	2' Miter	4' Miter	6' Miter
Fan Motor (TLD(L/R))	5125532 5 Watt	5125532 5 Watt	5125532 5 Watt
Fan Motor Brackets (TLD(L/R))	5962269	5962269	5962269
Fan Bracket Plate (TLD(L/R))	9041077	9041077	9041077
Fan Blades			
(7" 20° 5B) (TLD(L/R))	5960943	5960943	-----
(7" 25° 5B) (TLD(L/R))	-----	-----	5236974
Rocker Switch	5961377	5961377	5961377
Rectangular Outlet	5236335	5236335	5236335
T-8 Lamp Ballast			
(canopy)(1-row)	5991029	5991029	5991029
(opt. can.)(2-row)(TLD(L/R))	5991029	5991029	5991029
(opt. shelf)(per row)	5991029	5991029	5991029
(opt. nose light)(1-row)	5991029	5991029	5991029
T-8 Lampholder (canopy)	9041897	9041897	9041897
T-8 Shelf Harness	9027906	9027906	9027906
Anti-Sweat Heater Wire			
Front Glass	9812817	9053345	9053378
Light Shield (TLD(L/R))	9812818	9053343	9053379
Anti-Fog Fan Motor	9801270	9801270	9801270
Anti-Sweat Heater Deflector Kit			
Lower Rear Door Frame (TLD(L/R))	-----	9811115	9811113
Hydro-Lift Gas Piston (200 N)	9801274 (4)	-----	-----
(500 N)	-----	9457248 (4)	-----
(300 N)	-----	-----	5152395 (8)
Hydro-Lift Piston Tool	5152656	5152656	5152656
(Required to remove pistons)			
Suction Solenoid Valve	5191445	5191445	5191445
Electronic Thermostat	9043552	9043552	9043552
Check Valve (TLM(L/R))	5199417	5199417	5199417

For information on operational parts not listed above contact the TYLER Service Parts Department.