

Medium Profile Unit Cooler

Publication No. 102.3
December, 1999



Air Defrost – 12,600 to 69,000 BTUH
Electric Defrost – 10,500 to 52,000 BTUH
Hot Gas Defrost – 10,500 to 52,000 BTUH

Medium to Large
Walk-Ins

Cooler & Freezer
Applications



Features

- **APPLICATIONS** — Inter-Temp unit coolers are ideally suited for a wide range of coolers and freezers. ITA models are designed for use in coolers above 35°F. ITE, ITG, and ITH units are suited for 35°F coolers, when mechanical defrosts are required, as well as for freezers with temperatures ranging down to -30°F.
- **Sizes** — There are 37 models offered, with capacities from 10,500 BTUH up to 69,000 BTUH @ 10°TD. Air flow ranges from 3,320 CFM to 9,130 CFM.
- **HOUSING** — Each unit is constructed with a rust-free, heavy gauge, textured, aluminum housing which is light weight yet extremely durable. Air and electric defrost models have hinged drain pans to allow for convenient servicing and maintenance (Hot Gas drain pans are not hinged). Slotted hangers are provided on all units for fast installation.
- **COIL** — Seamless copper tubes are staggered and mechanically expanded into heavy gauge corrugated aluminum fins to assure maximum heat transfer. Die formed fin collars are provided for accurate fin spacing. Heavy gauge hangers are fastened directly to the tube sheet of the coil to provide high structural strength.
- **REFRIGERANTS** — Inter-Temp unit coolers are designed for most refrigerants including, R-22, R-404A, R-134a, R-502 and R-507. Please specify system refrigerant requirements when ordering. A separate compartment is provided for all refrigerant connections which allows ample room for internal mounting of expansion valves. Inter-Temps can also be used with chilled water or glycol solutions, contact factory for selection.
- **Fans** — Powerful heavy duty aluminum fans are individually balanced to provide vibration free operation.
- **Wire fan guards** — Standard heavy gauge wire fan guards are epoxy coated for corrosion resistance. Optional air straighteners are available for increased air throw when required.
- **Motors** — All motors are high efficiency PSC, ball bearing type, life lubricated and thermally protected. Inter-Temp unit coolers use either 1/8 HP, 1050 rpm or 1/3 HP, 1075 rpm motors.
- **ELECTRICAL** — Available in 115V/1, 208/230/1, 208/230/3, 460/1 or 460/3. Inter-Temps can also be operated on 220/1/50, 220/3/50, 380/1/50 and 380/3/50 power. All components are factory wired to convenient screw type terminal blocks. A large compartment is supplied for all electrical components and is easily accessible by removing the end panel.
- **AIR DEFROST** — Available on ITA series only, for use in coolers at +35°F and above. Complete air defrost systems are available from Russell.
- **ELECTRIC DEFROST** — These units are available as ITE models. The placement of heaters within the refrigeration coil allows for a more efficient and rapid defrost cycle than other designs. This arrangement enables the energy from the heaters to be conducted from the center of the core out, providing an even defrost pattern. All heaters are factory installed and wired to screw type terminal blocks, allowing for quick field hook up or change over from 1 to 3 phase with the installation of jumper wires. Separate, fixed defrost termination, fan delay and heater safety controls are factory mounted for optimum performance of each control function. Drain pans are heated for fast, reliable drainage. Timer and contactors are available as options. Complete electric defrost systems are available from Russell. Contact the factory for details.
- **HOT GAS RE-EVAP DEFROST** — Available on all but the ITA models. These units include separate fixed defrost termination and fan delay controls which are factory mounted for optimum performance of each control function. A hot gas drain pan circuit is provided, thus eliminating the need for electric heat and additional wiring. A heat exchanger/re-evaporator is supplied with every unit. Refer to the current Russell Technical Bulletin HG for piping. Complete Hot Gas Re-Evap systems are available from Russell, contact the factory for details.
- **HOT GAS REVERSE CYCLE DEFROST** — Available on all but the ITA models. These units include separate fixed defrost termination and fan delay controls which are factory mounted for optimum performance of each control function. A hot gas drain pan circuit is provided, thus eliminating the need for electric heat and additional wiring. Refer to the current Russell Technical Bulletin HG for piping. This unit is also used for Alternating Evaporator System.

Options

- Copper fins
- Coated fins (air and hot gas defrost models only)
- Galvanized steel housing
- Insulated drain pans
- Custom circuiting for chilled water or glycol applications
- High throw fan guards (air straighteners)
- Reheat kit.
- Adjustable DTFD
- Contact factory for other requirements

Air Throw

Air throw is greatly affected by installation variables. Optimum air throw is obtained by high ceiling with no interference from beams, or return air restrictions. Inter-Temp unit coolers will throw air up to 50 feet under ideal conditions, 60 to 70 feet with air straighteners.

NOMENCLATURE

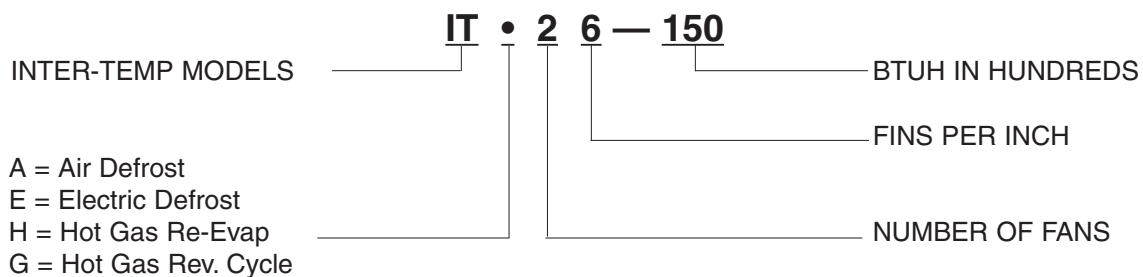

Performance Data

FREEZER 4 F P I	MODEL NUMBER	CFM	CAPACITY BTUH @ 10°TD (R404A, R22)				
			-30°F	-20°F	-10°F	+10°F	+25°F
			IT*24-105	3940	10000	10500	11100
IT*24-140	3620	13400	14000	14600	15900	16900	
IT*34-175	5750	16700	17500	18200	19800	22400	
IT*24-230	5930	21900	23000	24000	26000	28700	
IT*24-325	5430	31000	32500	33800	36800	40100	
IT*34-390	8990	37100	39000	40600	44100	46000	
IT*34-510	8150	48600	51000	53100	57700	58500	

FREEZER 6 F P I	MODEL NUMBER	CFM	CAPACITY BTUH @ 10°TD (R404A, R22)				
			-30°F	-20°F	-10°F	+10°F	+25°F
			IT*26-130	3780	12400	13000	13600
IT*26-150	3470	14300	15000	15600	17000	19100	
IT*36-185	5510	17600	18500	19300	21000	24000	
IT*26-270	5720	25700	27000	28100	29200	30500	
IT*26-320	5480	30500	32000	33300	35600	37000	
IT*36-385	9130	36700	38500	40100	43600	49000	
IT*36-460	9090	43800	46000	47900	52000	54800	
IT*36-520	8190	49500	52000	54100	58800	62000	

* E = Electric defrost

H = Hot gas defrost-Re evap

G = Hot gas defrost-Reverse cycle

COOLER 4 F P I	MODEL NUMBER	CFM	BTUH +25°F
	ITA24-126	3830	12600
	ITA24-169	3620	16900
	ITA34-224	5750	22400
	ITA34-287	5200	28700
	ITA24-340	5710	34000
	ITA24-395	5430	39500
	ITA34-465	8990	46500
	ITA34-585	8140	58500

COOLER 6 F P I	MODEL NUMBER	CFM	BTUH +25°F
	ITA26-145	3680	14500
	ITA26-191	3470	19100
	ITA36-240	5510	24000
	ITA36-305	4960	30500
	ITA26-370	5460	37000
	ITA36-415	8620	41500
	ITA36-490	8580	49000
	ITA36-620	7770	62000

COOLER 8 F P I	MODEL NUMBER	CFM	BTUH +25°F
	ITA28-151	3530	15100
	ITA28-210	3320	21000
	ITA38-260	5300	26000
	ITA38-320	4750	32000
	ITA28-410	5250	41000
	ITA28-450	5020	45000
	ITA38-540	8250	54000
ITA38-690	7470	69000	

For 50HZ applications, multiply BTUH capacity by .94 correction factor.

ELECTRIC DEFROST KITS

FREEZER	MODEL NUMBER	1 EVAPORATOR				2 EVAPORATORS				3 EVAPORATORS			
		230/1	230/3	460/1	460/3	230/1	230/3	460/1	460/3	230/1	230/3	460/1	460/3
		4 FPI	ITE24-105	ED-10	ED-11	ED-12	ED-12	ED-23	ED-21	ED-22	ED-22	ED-35	ED-33
	ITE24-140	ED-10	ED-11	ED-12	ED-12	ED-23	ED-21	ED-22	ED-22	ED-35	ED-33	ED-34	ED-32
	ITE34-175	ED-11	ED-11	ED-12	ED-12	ED-25	ED-23	ED-22	ED-22	ED-35	ED-35	ED-34	ED-32
	ITE24-230	ED-11	ED-11	ED-12	ED-12	ED-25	ED-23	ED-22	ED-22	ED-35	ED-35	ED-34	ED-32
	ITE24-325	ED-11	ED-11	ED-12	ED-12	ED-25	ED-23	ED-22	ED-22	ED-35	ED-35	ED-34	ED-32
	ITE34-390	ED-13	ED-11	ED-12	ED-12	ED-25	ED-23	ED-24	ED-22	ED-37	ED-35	ED-36	ED-34
	ITE34-510	ED-13	ED-11	ED-12	ED-12	ED-25	ED-23	ED-24	ED-22	ED-37	ED-35	ED-36	ED-34

FREEZER	MODEL NUMBER	1 EVAPORATOR				2 EVAPORATORS				3 EVAPORATORS			
		230/1	230/3	460/1	460/3	230/1	230/3	460/1	460/3	230/1	230/3	460/1	460/3
		6 FPI	ITE26-130	ED-10	ED-11	ED-12	ED-12	ED-23	ED-21	ED-22	ED-22	ED-35	ED-33
	ITE26-150	ED-10	ED-11	ED-12	ED-12	ED-23	ED-21	ED-22	ED-22	ED-35	ED-33	ED-34	ED-32
	ITE36-185	ED-11	ED-11	ED-12	ED-12	ED-25	ED-23	ED-22	ED-22	ED-35	ED-35	ED-34	ED-32
	ITE26-270	ED-11	ED-11	ED-12	ED-12	ED-25	ED-23	ED-22	ED-22	ED-35	ED-35	ED-34	ED-32
	ITE26-320	ED-11	ED-11	ED-12	ED-12	ED-25	ED-23	ED-22	ED-22	ED-35	ED-35	ED-34	ED-32
	ITE36-385	ED-13	ED-11	ED-12	ED-12	ED-25	ED-23	ED-24	ED-22	ED-37	ED-35	ED-36	ED-34
	ITE36-460	ED-13	ED-11	ED-12	ED-12	ED-25	ED-23	ED-24	ED-22	ED-37	ED-35	ED-36	ED-34
	ITE36-520	ED-13	ED-11	ED-12	ED-12	ED-25	ED-23	ED-24	ED-22	ED-37	ED-35	ED-36	ED-34

ELECTRIC DEFROST KIT COMPONENTS

MODEL NUMBER	TIMER	AUXILIARY SWITCH	BLOCKOUT RELAY	CONTACTORS		SEQUENCING RELAY
				HEATER	FAN	
ED-10	1	—	1-30A	—	—	—
ED-11	1	1	—	1-30A	—	—
ED-12	1	1	—	1-30A	1-25A	—
ED-13	1	1	—	1-50A	—	—
ED-14	1	1	—	1-50A	1-25A	—
ED-15	1	1	—	2-50A	—	—
ED-16	1	1	—	2-50A	1-25	—
ED-20	1	—	1-30A	—	—	2
ED-21	1	1	—	2-15A	—	2
ED-22	1	1	—	2-15A	1-25A	2
ED-23	1	1	—	2-25A	—	2
ED-24	1	1	—	2-25A	1-25	2
ED-25	1	1	—	2-50A	—	2
ED-26	1	1	—	2-50A	1-25A	2
ED-27	1	1	—	2-75A	—	2
ED-28	1	1	—	2-75A	1-25A	2
ED-30	1	—	1-30A	—	—	3
ED-32	1	1	—	3-10A	1-25A	3
ED-33	1	1	—	3-15A	—	3
ED-34	1	1	—	3-15A	1-25A	3
ED-35	1	1	—	3-30A	—	3
ED-36	1	1	—	3-30A	1-25A	3
ED-37	1	1	—	3-50A	—	3
ED-38	1	1	—	3-50A	1-25A	3

Timer

Initiates the defrost cycle, also acts as an override protection device for defrost termination.

Auxiliary Switch

Mounted on the compressor contactor, it prevents the defrost contactor from operating when the compressor is energized.

Block-out Relay

Serves the same function as the auxiliary switch, except used when a defrost contactor is not required(single phase only).

Fan Contactor

Used with 460V motors or when 230v motors are wired for three phase operation.

Defrost Contactor

Carries the amperage load for the heater circuit. Contactor selection is based upon the maximum resistive load rating of the contactor.

Sequencing Relay

Provides interconnection of multiple unit coolers an a single compressor system. This allows each unit cooler to individually terminate defrost on temperature.

Electrical Data

	MODEL NUMBER	TOTAL MOTOR AMPS 60 HZ			
		115 V†	208/230 V		460 V
		1 PH	1 PH	3 PH	1 PH
F R E E Z E R 4 P H I	IT*24-105	4.0	1.8	—	0.9
	IT*24-140	4.0	1.8	—	0.9
	IT*34-175	6.0	2.7	—	1.4
	IT*24-230	14.2	6.4	—	2.6
	IT*24-325	14.2	6.4	—	2.6
	IT*34-390	21.3	9.6	5.5	3.9
	IT*34-510	21.3	9.6	5.5	3.9

ELECTRIC DEFROST AMPERAGE RATINGS @60 HZ						
208 V		230 V		460 V		WATTS
1 PH	3 PH	1 PH	3 PH	1 PH	3 PH	
18.3	10.5	20.3	11.7	10.1	5.9	4685
18.3	10.5	20.3	11.7	10.1	5.9	4685
26.6	15.3	29.5	17.0	14.7	8.5	6774
26.6	15.3	29.5	17.0	14.7	8.5	6774
26.5	15.3	29.5	17.0	14.7	8.5	6774
38.2	22.1	42.4	24.5	21.2	12.2	9747
38.2	22.1	42.4	24.5	21.2	12.2	9747

	MODEL NUMBER	TOTAL MOTOR AMPS 60 HZ			
		115 V†	208/230 V		460 V
		1 PH	1 PH	3 PH	1 PH
F R E E Z E R 6 P H I	IT*26-130	4.0	1.8	—	0.9
	IT*26-150	4.0	1.8	—	0.9
	IT*36-185	6.0	2.7	—	1.4
	IT*26-270	14.2	6.4	—	2.6
	IT*26-320	14.2	6.4	—	2.6
	IT*36-385	21.3	9.6	5.5	3.9
	IT*36-460	21.3	9.6	5.5	3.9
	IT*36-520	21.3	9.6	5.5	3.9

18.3	10.5	20.3	11.7	10.1	5.9	4685
18.3	10.5	20.3	11.7	10.1	5.9	4685
26.6	15.3	29.5	17.0	14.7	8.5	6774
26.6	15.3	29.5	17.0	14.7	8.5	6774
26.5	15.3	29.5	17.0	14.7	8.5	6774
38.2	22.1	42.4	24.5	21.2	12.2	9747
38.2	22.1	42.4	24.5	21.2	12.2	9747
38.2	22.1	42.4	24.5	21.2	12.2	9747

* E = Electric defrost G = Hot gas defrost - Reverse cycle H = Hot gas Re-Evap

† 115V Available for Hot Gas Defrost units only.

Air Defrost Units

	MODEL NUMBER	TOTAL MOTOR AMPS 60 HZ			
		115V	208/230V		460V
		1PH	1PH	3PH	1PH
C O O L E R 4 P H I	ITA24-126	4.0	1.8	—	0.9
	ITA24-169	4.0	1.8	—	0.9
	ITA34-224	6.0	2.7	—	1.4
	ITA34-287	6.0	2.7	—	1.4
	ITA24-340	14.2	6.4	—	2.6
	ITA24-395	14.2	6.4	—	2.6
	ITA34-465	21.3	9.6	5.5	3.9
	ITA34-585	21.3	9.6	5.5	3.9

	MODEL NUMBER	TOTAL MOTOR AMPS 60 HZ			
		115V	208/230V		460V
		1PH	1PH	3PH	1PH
C O O L E R 6 P H I	ITA26-145	4.0	1.8	—	0.9
	ITA26-191	4.0	1.8	—	0.9
	ITA36-240	6.0	2.7	—	1.4
	ITA36-305	6.0	2.7	—	1.4
	ITA26-370	14.2	6.4	—	2.6
	ITA36-415	21.3	9.6	5.5	3.9
	ITA36-490	21.3	9.6	5.5	3.9
	ITA36-620	21.3	9.6	5.5	3.9

	MODEL NUMBER	TOTAL MOTOR AMPS 60 HZ			
		115V	208/230V		460V
		1PH	1PH	3PH	1PH
C O O L E R 8 P H I	ITA28-151	4.0	1.8	—	0.9
	ITA28-210	4.0	1.8	—	0.9
	ITA38-260	6.0	2.7	—	1.4
	ITA38-320	6.0	6.4	—	2.6
	ITA28-410	14.2	6.4	—	2.6
	ITA28-450	14.2	6.4	—	2.6
	ITA38-540	21.3	9.6	5.5	3.9
	ITA38-690	21.3	9.6	5.5	3.9

Physical Data

FREEZER	MODEL NUMBER	FAN DIA. (in)	MOTOR DATA			OPTIONAL HEAT EXCH (UNMTD.)	RE-EVAP HEAT EXCH (UNMTD.)	CONNECTIONS (in.)				SHIP WT. (lbs)
			QTY.	HP	RPM			LIQUID ODS	SUCTION ODS	H.G. ODS	DRAIN MPT	
4	IT*24-105	14	2	1/8	1050	RXH150	HEA3A	1/2	1 1/8	7/8	3/4	120
	IT*24-140	14	2	1/8	1050	RXH150	HEA3A	1/2	1 1/8	7/8	3/4	135
	IT*34-175	14	3	1/8	1050	RXH150	HEA3A	1/2	1 1/8	7/8	3/4	285
	IT*24-230	20	2	1/3	1075	RXH250	HEA4A	1/2	1 3/8	7/8	3/4	315
	IT*24-325	20	2	1/3	1075	RXH350	HEA4A	7/8	1 3/8	7/8	3/4	350
	IT*34-390	20	3	1/3	1075	RXH350	HEA4A	7/8	1 5/8	7/8	3/4	435
	IT*34-510	20	3	1/3	1075	RXH500	HEA5A	7/8	1 5/8	7/8	3/4	530

6	IT*26-130	14	2	1/8	1050	RXH150	HEA3A	1/2	1 1/8	7/8	3/4	125
	IT*26-150	14	2	1/8	1050	RXH150	HEA3A	1/2	1 1/8	7/8	3/4	140
	IT*36-185	14	3	1/8	1050	RXH150	HEA3A	1/2	1 1/8	7/8	3/4	295
	IT*26-270	20	2	1/3	1075	RXH250	HEA4A	1/2	1 3/8	7/8	3/4	320
	IT*26-320	20	2	1/3	1075	RXH350	HEA4A	7/8	1 3/8	7/8	3/4	365
	IT*36-385	20	3	1/3	1075	RXH350	HEA4A	7/8	1 5/8	7/8	3/4	450
	IT*36-460	20	3	1/3	1075	RXH500	HEA5A	7/8	1 5/8	7/8	3/4	490
	IT*36-520	20	3	1/3	1075	RXH500	HEA5A	7/8	1 5/8	7/8	3/4	535

Air Defrost Units

COOLER	MODEL NUMBER	FAN DIA. (in)	MOTOR DATA			OPTIONAL HEAT EXCH (UNMTD.)	RE-EVAP HEAT EXCH (UNMTD.)	CONNECTIONS (in.)				SHIP WT (lbs)
			QTY.	HP	RPM			LIQUID ODS	SUCTION ODS	H.G. ODS	DRAIN MPT	
4	ITA24-126	14	2	1/8	1050	RXH150	N/A	1/2	7/8	N/A	3/4	115
	ITA24-169	14	2	1/8	1050	RXH150	N/A	1/2	7/8	N/A	3/4	130
	ITA34-224	14	3	1/8	1050	RXH150	N/A	1/2	7/8	N/A	3/4	280
	ITA34-287	14	3	1/8	1050	RXH250	N/A	1/2	1 1/8	N/A	3/4	310
	ITA24-340	20	2	1/3	1075	RXH250	N/A	7/8	1 1/8	N/A	3/4	345
	ITA24-395	20	2	1/3	1075	RXH250	N/A	7/8	1 1/8	N/A	3/4	375
	ITA34-465	20	3	1/3	1075	RXH250	N/A	7/8	1 3/8	N/A	3/4	400
	ITA34-585	20	3	1/3	1075	RXH350	N/A	7/8	1 3/8	N/A	3/4	505

6	ITA26-145	14	2	1/8	1050	RXH150	N/A	1/2	7/8	N/A	3/4	120
	ITA26-191	14	2	1/8	1050	RXH150	N/A	1/2	7/8	N/A	3/4	140
	ITA36-240	14	3	1/8	1050	RXH150	N/A	1/2	7/8	N/A	3/4	290
	ITA36-305	14	3	1/8	1050	RXH250	N/A	1/2	1 1/8	N/A	3/4	320
	ITA26-370	20	2	1/3	1075	RXH250	N/A	7/8	1 1/8	N/A	3/4	360
	ITA36-415	20	3	1/3	1075	RXH250	N/A	7/8	1 1/8	N/A	3/4	395
	ITA36-490	20	3	1/3	1075	RXH250	N/A	7/8	1 3/8	N/A	3/4	415
ITA36-620	20	3	1/3	1075	RXH350	N/A	7/8	1 3/8	N/A	3/4	520	

8	ITA28-151	14	2	1/8	1050	RXH150	N/A	1/2	7/8	N/A	3/4	125
	ITA28-210	14	2	1/8	1050	RXH150	N/A	1/2	7/8	N/A	3/4	145
	ITA38-260	14	3	1/8	1050	RXH250	N/A	1/2	1 1/8	N/A	3/4	295
	ITA38-320	14	3	1/8	1050	RXH250	N/A	1/2	1 1/8	N/A	3/4	330
	ITA28-410	20	2	1/3	1075	RXH250	N/A	7/8	1 1/8	N/A	3/4	370
	ITA28-450	20	2	1/3	1075	RXH250	N/A	7/8	1 3/8	N/A	3/4	390
	ITA38-540	20	3	1/3	1075	RXH350	N/A	7/8	1 3/8	N/A	3/4	430
	ITA38-690	20	3	1/3	1075	RXH350	N/A	7/8	1 3/8	N/A	3/4	540

Dimensions – All Models

ELECTRIC AND HOT GAS DEFROST		AIR DEFROST MODELS			FIG.	DIMENSIONS		
						W	A	B
IT*24-105	IT*26-130	ITA24-126	ITA26-145	ITA28-151	1	55	42	—
IT*24-140	IT*26-150	ITA24-169	ITA26-191	ITA28-210	1	55	42	—
IT*34-175	IT*36-185	ITA34-224	ITA36-240	ITA38-260	1	76	63	—
—	—	ITA34-287	ITA36-305	ITA38-320	1	76	63	—
IT*24-230	IT*26-270	ITA24-340	ITA26-370	ITA28-410	2	76	63	31-1/2
IT*24-325	IT*26-320	ITA24-395	—	ITA28-450	2	76	63	31-1/2
—	IT*36-385	—	ITA36-415	—	2	106	93	31
IT*34-390	IT*36-460	ITA34-455	ITA36-490	ITA38-540	2	106	93	31
IT*34-510	IT*36-520	ITA34-585	ITA36-620	ITA38-690	2	106	93	31

* **E** = Electric defrost

H = Hot gas defrost - Re evap

G = Hot gas defrost - Reverse cycle

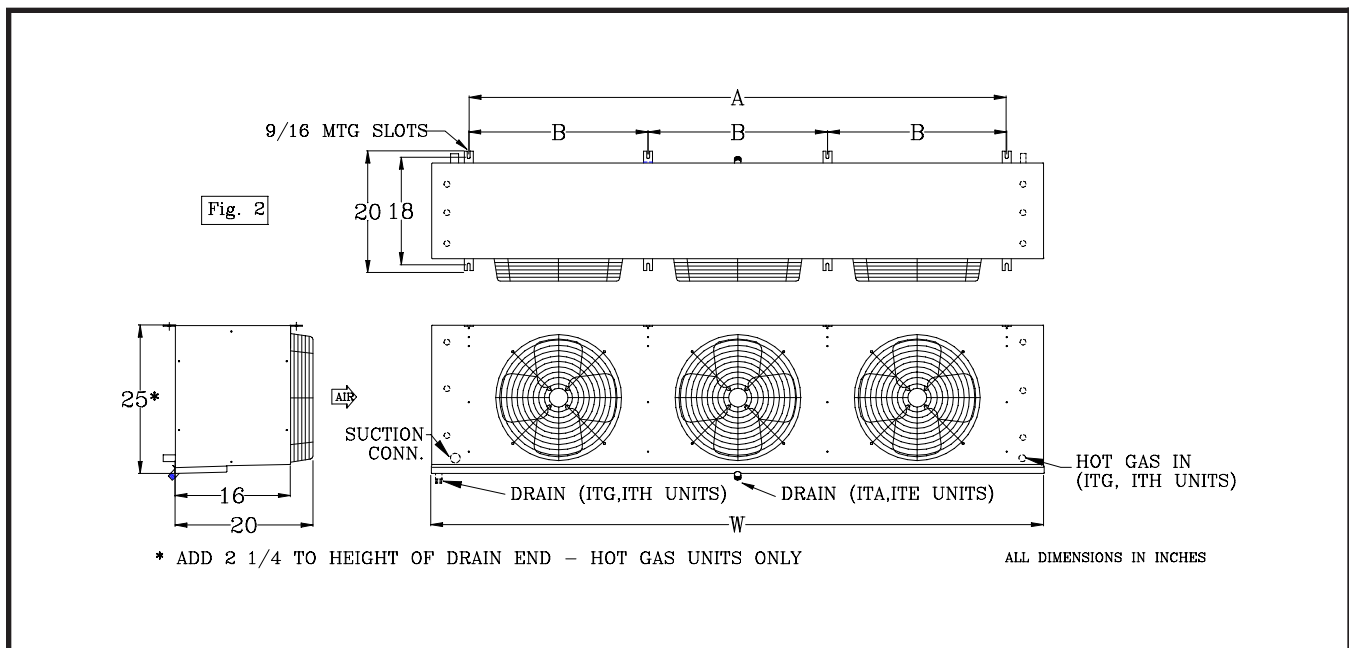
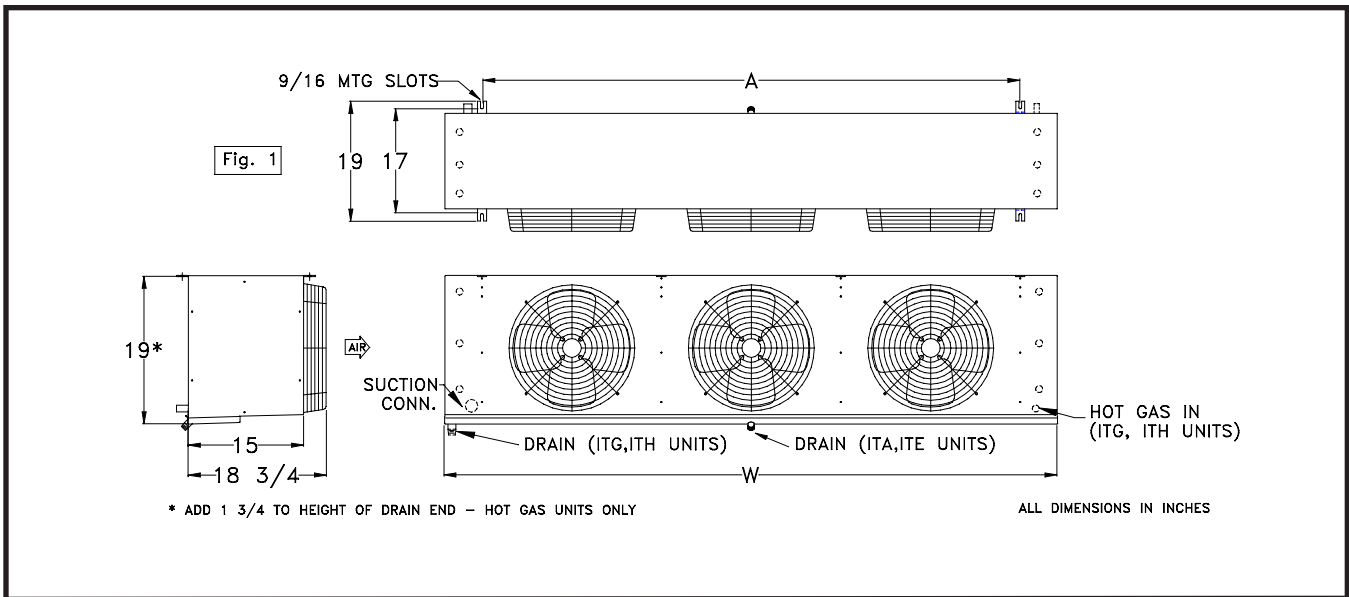

3/4" MPT drain connections on all units.