

You need an edge.

ECOBLADE SHELF EDGE TECHNOLOGY

Retrofit your Shelves with EcoBlade® to:

CUT refrigeration energy use up to 33%.

CUT food spoilage and waste.

CUT uncomfortable cold air spill.

CUT losses that eat away at your bottom line!

Applications:

1. Fits a range of 3' and 4' flat and angled shelf depths with standard and slotted tag molding.
2. Choose Black or White EcoBlades to match case interiors.

PARTS
ONE
ANTHONY|HILLPHOENIX

Parts One Solution.

Parts ONE offers a turnkey retrofit program that includes a strategic match of your stores and specific case requirements with the complete EcoBlade kits to fit them. We look at case

types, dimensions, colors, lit or unlit and style of tag molding. Then Parts ONE installers come to your stores and install EcoBlade without any interruption in store traffic.

Essentially, installing EcoBlade is an effortless undertaking that lets you concentrate on business while you add up your energy savings.

Get Your Edge.

Hillphoenix offers a total turnkey operation. We can even help you with your ROI and field testing. Interested? The sooner you get in touch the sooner you get your edge. **Email us at:** askparts@doverfoodretail.com. Leave us your store number, and contact name and information.



ecoblade®

hillphoenix.com/display-case/ecoblade/



**PARTS
ONE**
ANTHONY HILLPHOENIX

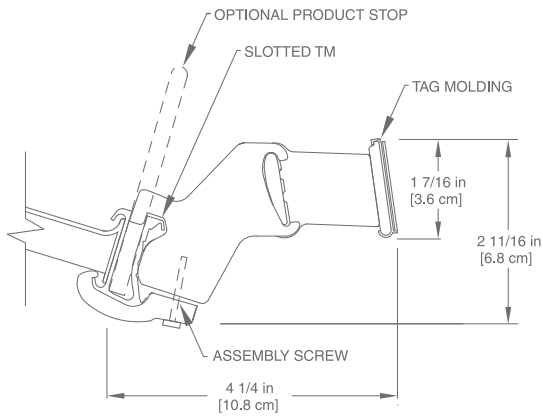

ANGLED SHELF APPLICATION

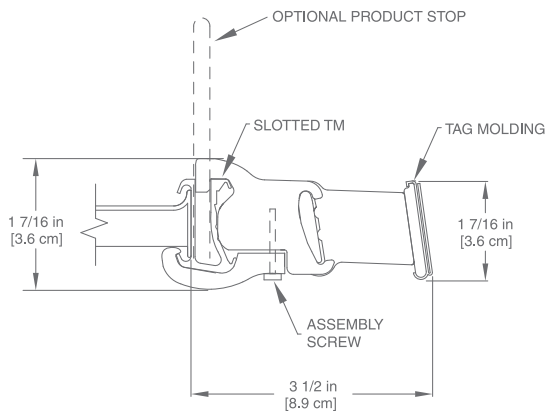

FLAT SHELF SLOTTED APPLICATION

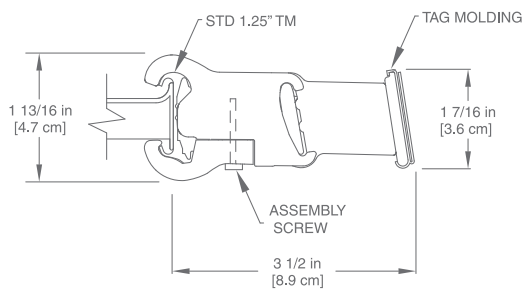

FLAT SHELF STANDARD APPLICATION

For more information go to
hillphoenix.com/display-case/ecoblade/