

# Self-Service Multi-Deck

Refrigerated general merchandiser.

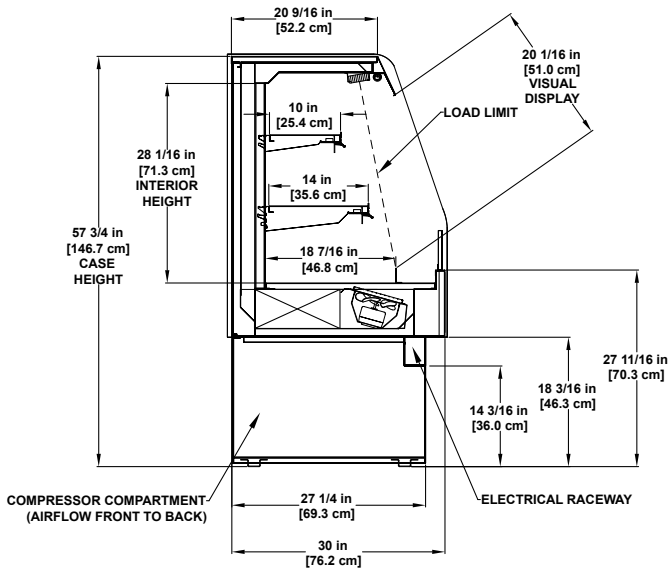



Please consult Hillphoenix Engineering Reference Manual for dimensions, plan views and technical specifications. Specifications subject to change without notice. Designed for optimal performance in store environments where temperature and humidity do not exceed 80° F and 55% R.H. Certified to UL 471 and ANSI/NSF Standard 7.

## Base Model Features

- Closed base construction with leveling pads.
- Case dimensions: 57-3/4"H and 30"D.
- 18-3/16"H painted metal base, front and sides.
- Painted metal exterior.
- Outside back and 20-9/16"D case top painted to match exterior.
- Stainless steel exterior trim.
- 5-1/2"H x 1/2" thick polished, straight die board plex.
- Painted Matte black metal interior and trim.
- (1) row Clearvoyant® LED canopy top light.
- (1) row each 10" and 14" non-lighted adjustable angled (0°, 5° and 15°) black painted metal shelving with black price tag molding with 3" polycarbonate product stop.
- Painted black metal, flat bottom deck with 2" metal product stop.
- Main power switch and on/off light switch.
- Solar digital thermometer.
- Refrigeration: R-290, high-efficiency fan motors, and digital temperature control with automatic defrost.
- Front electrical raceway.
- Front to back airflow.
- 6' Cord and plug.

## Available Options

- Case lengths: 2' & 4'.
- No miters or wedges available.
- Exterior finishes: Exterior grade laminate or stainless steel.
- Painted metal base trim.
- White or stainless steel case interior.
- Clearvoyant® LED under shelf lighting.
- Solid or full-view end panels with mirror-polished, stainless steel interior.
- Cart bumper mounted on front panel of case.
- Cart bumper added to end panels.
- Exposed casters on 2' length.
- Recessed casters on 4' length.
- Econofrost night cover with or without cassette.
- Polycarbonate night cover.
- Magnetic night shield.
- 3" rear exhaust chimney.



*This self-contained models utilize Second Nature® NATURAL environmentally friendly R-290 hydrocarbon refrigerant that has zero (0) ozone depletion potential (ODP) and three (3) global warming potential.*

Listed for NSF Type 2.



Dover Food Retail  
Conyers, GA USA  
844.591.5937  
hillphoenix.com

**Hillphoenix**

©2021 Hillphoenix, Inc.